

PX-5S

MIDI Implementation

CASIO COMPUTER CO., LTD.

Contents

I	Overview	6
1	Product Configuration as a MIDI Device	6
1.1	System Section	6
1.2	Performance Controller Section	6
1.3	Sound Generator Section	6
2	Timbre Type Specific Operation	7
3	Controlling Send/Receive of MIDI Messages in Each Instrument Part	7
4	Conditions that Disable Message Send and Receive	7
II	Channel Message	8
5	Note Off	8
6	Note On	9
7	Control Change	9
7.1	Bank Select (00H,20H)	9
7.2	Modulation (01H)	10
7.3	Portamento Time(05H)	10
7.4	Data Entry (06H,26H)	10
7.5	Volume (07H)	10
7.6	Pan (0AH)	11
7.7	Expression (0BH)	11
7.8	General Use Controllers 1 through 8 (10H through 13H, 50H through 53H)	11
7.9	Hold1 (40H)	12
7.10	Portamento On/Off(41H)	13
7.11	Sostenuto (42H)	13
7.12	Soft (43H)	13
7.13	Filter Resonance(47H)	13
7.14	Release Time (48H)	14
7.15	Attack Time (49H)	14
7.16	Filter Cutoff (4AH)	14
7.17	Vibrato Rate (4CH)	14
7.18	Vibrato Depth (4DH)	15

7.19	Vibrato Delay (4EH)	15
7.20	Portamento Control(54H)	15
7.21	High Resolution Velocity Prefix (58H)	15
7.22	Reverb Send (5BH)	16
7.23	Chorus Send (5DH)	16
7.24	Delay Send (5EH)	16
7.25	NRPN (62H,63H)	16
7.26	RPN (64H,65H)	19
7.27	All Sound Off (78H)	21
7.28	Reset All Controllers (79H)	21
7.29	All Notes Off (7BH)	21
7.30	Omni Off (7CH)	21
7.31	Omni On (7DH)	21
7.32	Mono (7EH)	21
7.33	Poly (7FH)	22
8	Program Change	22
9	Channel After Touch	23
10	Pitch Bend	23
III	System Message	24
11	Timing Clock	24
12	Start	24
13	Continue	24
14	Stop	24
15	Active Sensing	24
16	System Exclusive Message	25
16.1	Universal Real Time System Exclusive Message	25
16.2	Universal Non Real Time System Exclusive Message	27
16.3	Instrument-Specific System Exclusive Message	28
IV	Instrument-Specific System Exclusive Messages	29
17	Format	29
17.1	Message Classifications	29
17.2	Basic Message Structure	29
17.3	Format of Each Field	30
18	Individual Parameter Operations	38
19	Parameter Set Transfer	38
19.1	Communication Modes	38
19.2	One-way Mode Communication Flow	39
19.3	Handshake Mode Communication Flow	40

V	Parameter List	48
20	Using the Parameter List	48
21	System Parameter	48
21.1	System Information Parameter	48
21.2	System Version Information	49
21.3	Data Management Parameter	49
21.4	System Exclusive Protocol Parameter	49
22	Patch Parameter	50
22.1	Master EQ Parameter	50
22.2	Master Tune Parameter	51
22.3	Master Mixer Parameter	51
22.4	Master Compressor Parameter	51
22.5	Part Parameter	52
22.6	System Chorus Parameter	52
22.7	System Delay Parameter	52
22.8	System Reverb Parameter	53
22.9	System Resonance Parameter	53
22.10	Patch Etc Parameter	53
22.11	Pedal Parameter	54
22.12	Controller Parameter	55
23	Tone Parameter	55
23.1	DSP Parameter	55
23.2	LFO Parameter	55
23.3	Pan Parameter	56
23.4	Portamento Parameter	56
23.5	ToneBlock Parameter	56
23.6	Tone Production Parameter	57
24	Drum Parameter	57
24.1	Instrument Parameter (x128instrument)	57
25	Hex Layer Parameter	58
25.1	Hex Layer Parameter	59
25.2	Hex Layer LFO Parameter	59
25.3	Hex Layer Tone Edit Parameter (x6layer)	59
26	Arpeggio Parameter	61
26.1	Arpeggio Directory Info	61
27	Phrase Parameter	61
27.1	Phrase Directory Info	61
28	Song Parameter	61
28.1	Song Directory Info	61
29	Spec Parameter	61
VI	Parameter Set List	63

30	Parameter Set Table	63
VII	DSP Parameter List	64
31	DSP Type List	64
32	DSP Parameter Set Type	64
32.1	Equalizer	64
32.2	Compressor	65
32.3	Limiter	65
32.4	Enhancer	65
32.5	Early Reflection	65
32.6	Phaser	65
32.7	Chorus	66
32.8	Flanger	66
32.9	Tremolo	66
32.10	Auto Pan	67
32.11	Rotary	67
32.12	Drive Rotary	67
32.13	LFO Wah	68
32.14	Auto Wah	68
32.15	Distortion	68
32.16	Pitch Shifter	69
32.17	Multi Chorus	69
32.18	Ring Modulator	69
32.19	Delay	69
32.20	Piano Effect	70
VIII	Setting Values and Send/ Receive Values	71
33	Setting Value Tables	71
33.1	Off/On Setting Value Table	71
33.2	DSP Bypass Setting Value Table	71
33.3	Sustain Pedal Setting Value Table	71
33.4	-64 - 0 - +63 Setting Value Table	71
33.5	Pan Setting Value Table	71
33.6	Fine Tuning Setting Value Table	72
33.7	Reverb Type Setting Value Table	72
33.8	Chorus Type Setting Value Table	72
33.9	EQ Frequency Setting Value Table	73
33.10	EQ Gain Setting Value Table	74
33.11	LFO Wave Form1 Setting Value Table	74
33.12	LFO Wave Form2 Setting Value Table	74
33.13	LFO Wave Form3 Setting Value Table	75
33.14	Polarity Setting Value Table	75
33.15	Slow/Fast Setting Value Table	75
33.16	Rotate/Stop Setting Value Table	75
33.17	Vibrato/Chorus Setting Value Table	76
33.18	Routing Setting Value Table	76
33.19	Amp Setting Value Table	76
33.20	Pitch Setting Value Table	77

33.21	Pitch Shifter Fine Setting Value Table	78
33.22	Feedback Type Setting Value Table	78
33.23	Delay Tempo Sync Setting Value Table	78
33.24	Lid Type Setting Value Table	78
33.25	-128 - 0 - +127 Setting Value Table	78
33.26	-256 - 0 - +255 Setting Value Table	79
33.27	Hex Layer Detune Setting Value Table	80
33.28	Octave Shift Setting Value Table	80

IX MIDI Implementation Notation 81

34	Value Notation	81
34.1	Hexadecimal Notation	81
34.2	Binary Notation	81

Part I

Overview

1 Product Configuration as a MIDI Device

As a MIDI device, this Instrument consists of the System Section, Sound Generator Section, and Performance Controller Section described below. Each of these sections can send and receive specific MIDI Messages in accordance with its function.

1.1 System Section

The System Section manages the Instrument status and user data. A communication method known as a “bulk dump” can be used for two-way transfer of user data between the Instrument and a computer.

1.2 Performance Controller Section

The Performance Controller Section performs keyboard play and controller operations, and generates performance messages in accordance with phrase play, etc. Basically, generated performance messages are sent to external destinations while also being transmitted to the Sound Generator Section. The channel number of the sent channel message is in accordance with the Instrument’s MIDI setting. For details about the MIDI setting, see the Instrument’s User’s Guide.

1.3 Sound Generator Section

The Sound Generator Section mainly performs receive of performance information and sound source setting information. It consists of a common part that does not depend on the channel and a musical instrument part that is independent of each channel.

1.3.1 Sound Generator Common Block

The common block consists of system effects, master control, etc. These can be controlled by mixer function, effect function, general universal system exclusive messages, or the Instrument’s system exclusive messages or all.

1.3.2 Instrument Part Block

The instrument part section consists of a total of 16 instrument parts. The settings of each part can be changed using the mixer function, channel messages or Instrument’s system exclusive messages or all. Part numbers 01 through 04 in particular are called zones, and zone settings can be used to modify operations. See the Instrument’s User’s Guide for details about zones.

The functions assigned to each part are shown below. The MIDI send channel and MIDI receive channel can be changed using the Instrument’s MIDI settings.

Part number	MIDI Receive Ch	MIDI Transmit Ch	Assigned Function(Note)
01	1	01 - 16	Song Sequencer/Zone 1/SMF play/MIDI IN
02	2	01 - 16	Song Sequencer/Zone 2/SMF play/MIDI IN
03	3	01 - 16	Song Sequencer/Zone 3/SMF play/MIDI IN
04	4	01 - 16	Song Sequencer/Zone 4/SMF play/MIDI IN
05	5	5	Song Sequencer/SMF play/MIDI IN
06	6	6	Song Sequencer/SMF play/MIDI IN
07	7	7	Song Sequencer/SMF play/MIDI IN
08	8	8	Song Sequencer/SMF play/MIDI IN
09	9	9	Song Sequencer/SMF play/MIDI IN
10	10	10	Song Sequencer/SMF play/MIDI IN
11	11	11	Song Sequencer/SMF play/MIDI IN
12	12	12	Song Sequencer/SMF play/MIDI IN
13	13	13	Song Sequencer/SMF play/MIDI IN
14	14	14	Song Sequencer/SMF play/MIDI IN
15	15	15	Song Sequencer/SMF play/MIDI IN
16	16	16	Song Sequencer/SMF play/MIDI IN

Note: Song sequencer playback can be assigned to up to eight parts. See the Instrument's User's Guide for details.

2 Timbre Type Specific Operation

The sound source operation performed for a sound generator instrument receive message may depend on the value of the Timbre Type (see “About the Timbre Type” in “8 Program Change”) of each part's operation mode. For details, see the explanation for each message.

3 Controlling Send/Receive of MIDI Messages in Each Instrument Part

Send and receive of MIDI messages for each instrument part can be controlled by mixer function and global Instrument MIDI settings, Performance MIDI settings, NRPN messages, and Instrument-specific system exclusive messages. See the Instrument's User's Guide for details.

4 Conditions that Disable Message Send and Receive

No MIDI messages at all can be sent or received while “Please Wait ...” is on the display.

Part II

Channel Message

MIDI Message Send by Controller These MIDI messages can be sent by assigning any control change from CC:00H to CC:65H, after touch, etc. to a controller (knob, slider, pedal, modulation, etc.) See the Instruments User's Guide for details.

Instrument Velocity Resolution The upper seven bits of the 14-bit resolution correspond to the Note On/Off message, while the lower seven bits correspond to the High Resolution Velocity Prefix message.

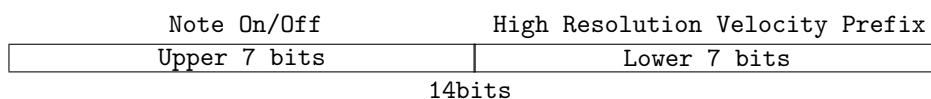

The initial default value for the lower 7 bits is 00H. Receipt of a High Resolution Prefix message causes the lower seven bits to be set, but note on/off is not performed.

Receipt of a Note On/Off message causes the upper seven bits to be set with note on/off performed with 14-bit resolution Velocity.

The High Resolution Velocity Prefix message corresponds the message immediately following the Note On/Off message, and the lower seven bits are cleared to 00H immediately following note on/off by the Note On/Off message. 7-bit resolution note on/off using only the Note On/Off message also continues to be supported.

For details about each message, see "5 Note Off", "6 Note On", and "7.21 High Resolution Velocity Prefix".

5 Note Off

Format

Message Format: 8nH kkH vvH
9nH kkH 00H(receive only)

n: MIDI Channel Number
kk: Key Number
vv: velocity

Transmit Sent when something is played on the keyboard or when play is performed using an arpeggio, etc. The key number changes in accordance with on the Transpose function and Octave Shift function.

Receive Receipt stops a note being sounded by a note on message.

When a High Resolution Velocity Prefix message is received immediately prior to the Note Off message and the lower seven bits of the 14-bit Velocity are set, the 14-bit resolution note off of the note being sounded is performed.

For information about the relationship between the Note On/Off message and High Resolution Velocity Prefix message, see "Instrument Velocity Resolution" at the beginning of part II.

Note off by making the Note On Velocity 00H is identical to note off by the combination of High Resolution Velocity prefix message 40H and Note Off Message 40H.

Note: This Instrument has a function that assumes connection of an external device that sends Note Off Velocity as a fixed value. Note Off Velocity 00H is replaced with 40H until a Note Off message with a Velocity value other than 00H is received. This function is enabled when the Instrument is turned on, and disabled by receipt of a Note Off message with a Velocity value other than 00H.

6 Note On

Message Format: 9nH kkH vvH

n: MIDI Channel Number
kk: Key Number
vv: Velocity

Transmit Sent when something is played on the keyboard or when play is performed using an arpeggio, etc. The key number changes in accordance with on the Transpose function and Octave Shift function.

Receive Receipt sounds a note of the corresponding instrument part.

When a High Resolution Velocity Prefix message is received immediately prior to the Note On message and the lower seven bits of the 14-bit Velocity are set, the 14-bit resolution note on is performed.

For information about the relationship between the Note On/Off message and High Resolution Velocity Prefix message, see "Instrument Velocity Resolution" at the beginning of part II.

7 Control Change

Message Format: BnH ccH vvH

n: MIDI Channel Number
cc: Control Number
vv: Value

For details about messages, see each section of this manual that covers them.

7.1 Bank Select (00H,20H)

Message Format: BnH 00H mmH (MSB)
BnH 20H llH (LSB)

n: MIDI Channel Number
mm: MSB Value(Note1)
ll: LSB Value(Transmit:00H, Receive:Ignored)

Note1: For details about the relationship between the MSB value and the tone, see the Tone List that comes with the Instrument.

Transmit Sent when a tone or stage setup number is selected.

Receive Receipt causes a change in the tone bank number stored in Instrument memory, but the tone is not actually changed until a Program Change message is received. For details, see “8 Program Change”.

The stage setup number can also be changed by the bank program. For details, see “8 Stage Setup Number Switching by Bank Select Message and Program Change Message”. For details about stage setups, see the Instrument’s User’s Guide.

7.2 Modulation (01H)

Message Format: BnH 01H vvH

n: MIDI Channel Number
vv: Value

Transmit Sent when the modulation wheel is operated.

Receive Receipt adds, to the tone being sounded, modulation of a depth specified by the value. In the case of a tone that already has modulation applied, receipt of this message increases the modulation depth. The modulation effect differs according to the tone being used.

7.3 Portamento Time(05H)

Message Format: BnH 05H vvH

n: MIDI Channel Number
vv: Value

Receive Receipt changes the portamento application time.

7.4 Data Entry (06H,26H)

Message Format: BnH 06H mmH (MSB)
BnH 26H llH (LSB)

n: MIDI Channel Number
mm: MSB Value
ll: LSB Value

Transmit Sent when there is a change to the parameter assigned to RPN, NRPN.

Receive Receipt changes the parameter assigned to RPN, NRPN.

7.5 Volume (07H)

Message Format: BnH 07H vvH

n: MIDI Channel Number
vv: Value

Transmit Sent when the mixer part volume is changed.

Receive Receipt changes the mixer part volume.

7.6 Pan (0AH)

Message Format: BnH 0AH vvH

n: MIDI Channel Number
vv: Value(Note1)

Note1: For information about the relationship between setting values and send/receive values, see "33.5 Pan Setting Value Table" in "VIII Setting Values and Send/Receive Values".

Transmit Sent when the pan of any part is changed.

Receive Receipt changes the pan of the corresponding part.

7.7 Expression (0BH)

Message Format: BnH 0BH vvH

n: MIDI Channel Number
vv: Value

Receive Receipt changes the Expression value.

7.8 General Use Controllers 1 through 8 (10H through 13H, 50H through 53H)

On this Instrument, these messages are used to control DSP operation.

Message Format:	BnH 10H vvH	DSP Parameter [1]
	BnH 11H vvH	DSP Parameter [2]
	BnH 12H vvH	DSP Parameter [3]
	BnH 13H vvH	DSP Parameter [4]
	BnH 50H vvH	DSP Parameter [5]
	BnH 51H vvH	DSP Parameter [6]
	BnH 52H vvH	DSP Parameter [7]
	BnH 53H vvH	DSP Parameter [8]

n: MIDI Channel Number
vv: Value

Receive Receipt changes the value of DSP Parameter [1 to 8] (7-bit parameter) assigned to the part specified by the MIDI Channel Number. Any message received that corresponds to the parameter of a number not being used by the currently selected DSP is ignored. Use NRPN to change DSP parameters from DSP Parameter [9] with a MIDI message. For details, see "7.25 NRPN". For details about each DSP parameter, see "VII DSP Parameter List".

Received values and parameter setting values The range of the value of each DSP Parameter 7 array element depends on the selected DSP or array number. Unlike manipulation of a DSP parameter using a System Exclusive Message, a value received by this control change message is always in the range of 0 to 127, but the range is changed in accordance with the setting range of the applicable parameter setting. Because of this, it is impossible for a value to be outside of the range. Conversion to the parameter setting value from the value received with the message can be represented in general terms by the expression shown below.

$$\text{Parameter Setting Value} = \text{Parameter Minimum Value} + (\text{Parameter Maximum Value} - \text{Parameter Minimum Value}) * \left(\frac{\text{Received Value}}{127} \right)$$

7.9 Hold1 (40H)

Message Format: BnH 40H vvH

n: MIDI Channel Number

vv: Value

Transmit Sent when a pedal that has a sustain (damper) function is operated.

Receive Receipt performs an operation equivalent to a sustain pedal operation.

Timbre Type Specific Operation This operation differs in accordance with the Timbre Type (see “About the Timbre Type” in “8 Program Change”) setting.

- Timbre Type: Melody,Hex Layer
Sustain off/on control is performed in accordance with the value of the received message. For information about the relationship between setting values and send/receive values, see the “ 33.1 Off/On Setting Value Table ” in “ VIII Setting Values and Send/Receive Values ”.
- Timbre Type: Piano
Continuous control of the following is performed in accordance with the value of the received message.
 - Piano note decay rate

For information about the relationship between setting values and send/receive values, see “ 33.3 Sustain Pedal Setting Value Table ” in “ VIII Setting Values and Send/Receive Values. ”
- Timbre Type: LM (Linear Morphing) Piano
Continuous control of the following is performed in accordance with the value of the received message.
 - Piano note decay rate
 - Resonance characteristics and decay rate of Damper Resonance effect resonance note

see “ 33.3 Sustain Pedal Setting Value Table ” in “ VIII Setting Values and Send/Receive Values. ”
- Timbre Type: Drum
The received message does not affect sound source operation.

7.10 Portamento On/Off(41H)

Message Format: BnH 41H vvH

n: MIDI Channel Number
vv: Value (Note1)

Note1: For information about the relationship between setting values and send/receive values, see the “33.1 Off/On Setting Value Table” in “VIII Setting Values and Send/Receive Values” of this document.

Receive Receipt changes the portamento on/off setting.

7.11 Sostenuto (42H)

Message Format: BnH 42H vvH

n: MIDI Channel Number
vv: Value (Note1)

Note1: For information about the relationship between setting values and send/receive values, see the “33.1 Off/On Setting Value Table” in “VIII Setting Values and Send/Receive Values” of this document.

Transmit Sent when a pedal that has a sostenuto function is operated.

Receive Receipt performs an operation equivalent to a sostenuto pedal operation.

7.12 Soft (43H)

Message Format: BnH 43H vvH

n: MIDI Channel Number
vv: Value (Note1)

Note1: For information about the relationship between setting values and send/receive values, see the “33.1 Off/On Setting Value Table” in “VIII Setting Values and Send/Receive Values” of this document.

Transmit Sent when a pedal that has a soft function is operated.

Receive Receipt performs an operation equivalent to a soft pedal operation.

7.13 Filter Resonance(47H)

Message Format: BnH 47H vvH

n: MIDI Channel Number
vv: Value

Receive Receipt changes the resonance intensity.

7.14 Release Time (48H)

Message Format: BnH 48H vvH

n: MIDI Channel Number
vv: Value (Note1)

Note1: For information about the relationship between setting values and send/receive values, see the “33.4 -64 - 0 - +63 Setting Value Table” in “VIII Setting Values and Send/Receive Values” of this document.

Receive Receipt makes a relative change in the time it takes for a note to decay to zero after a key is released.

7.15 Attack Time (49H)

Message Format: BnH 49H vvH

n: MIDI Channel Number
vv: Value (Note1)

Note1: For information about the relationship between setting values and send/receive values, see the “33.4 -64 - 0 - +63 Setting Value Table” in “VIII Setting Values and Send/Receive Values” of this document.

Receive Receipt makes a relative change in the time it takes for a note to rise to its maximum level.

7.16 Filter Cutoff (4AH)

Message Format: BnH 4AH vvH

n: MIDI Channel Number
vv: Value (Note1)

Note1: For information about the relationship between setting values and send/receive values, see the “33.4 -64 - 0 - +63 Setting Value Table” in “VIII Setting Values and Send/Receive Values” of this document.

Receive Receipt changes how the cut-off filter is applied.

7.17 Vibrato Rate (4CH)

Message Format: BnH 4CH vvH

n: MIDI Channel Number
vv: Value (Note1)

Note1: For information about the relationship between setting values and send/receive values, see the “33.4 -64 - 0 - +63 Setting Value Table” in “VIII Setting Values and Send/Receive Values” of this document.

Receive Receipt changes the note vibrato rate.

7.18 Vibrato Depth (4DH)

Message Format: BnH 4DH vvH

n: MIDI Channel Number

vv: Value (Note1)

Note1: For information about the relationship between setting values and send/receive values, see the “33.4 -64 - 0 - +63 Setting Value Table” in “VIII Setting Values and Send/Receive Values” of this document.

Receive Receipt changes the degree of pitch modulation.

7.19 Vibrato Delay (4EH)

Message Format: BnH 4EH vvH

n: MIDI Channel Number

vv: Value (Note1)

Note1: For information about the relationship between setting values and send/receive values, see the “33.4 -64 - 0 - +63 Setting Value Table” in “VIII Setting Values and Send/Receive Values” of this document.

Receive Receipt changes the time it takes until note vibrato starts.

7.20 Portamento Control(54H)

Message Format: BnH 54H vvH

n: MIDI Channel Number

vv: Source Key Number

Receive Receipt of this message first stores the Source Note Number for the next note. When the next Note On is received, the portamento effect is applied to the note using this Source Note Number as the pitch start point and the Note On event key number as the end point. If there already is a note being sounded by Source Note Number at this time, the new note on is not performed and the portamento effect is applied to the pitch of the note being sounded. That is to say that legato play is performed.

7.21 High Resolution Velocity Prefix (58H)

Message Format: BnH 58H vvH

n: MIDI Channel Number

vv: Value

Transmit Sends the lower seven bits of 14-bit Velocity when a key is pressed or released.

Receive Receipt is handled, in combination with the following Note On/Off message, as the lower seven bits of 14-bit Velocity. (Note1)

For information about the relationship between the Note On/Off message and High Resolution Velocity Prefix message, see “Instrument Velocity Resolution” at the beginning of part II.

7.22 Reverb Send (5BH)

Message Format: BnH 5BH vvH

n: MIDI Channel Number
vv: Value

Transmit Sent when the reverb send of any part is changed.

Receive Receipt changes the reverb send of the corresponding part.

7.23 Chorus Send (5DH)

Message Format: BnH 5DH vvH

n: MIDI Channel Number
vv: Value

Transmit Sent when the chorus send of any part is changed.

Receive Receipt changes the chorus send of the corresponding part.

7.24 Delay Send (5EH)

Message Format: BnH 5EH vvH

n: MIDI Channel Number
vv: Value

Transmit Sent when the delay send of any part is changed.

Receive Receipt changes the delay send of the corresponding part.

7.25 NRPN (62H,63H)

Message Format: BnH 62H 11H (LSB)
BnH 63H mmH (MSB)

n: MIDI Channel Number
11: LSB Value
mm: MSB Value

7.25.1 Part Enable

Message Format: BnH 62H 00H
BnH 63H 22H
BnH 06H mmH
BnH 26H 11H

n: MIDI Channel Number
mm: Value (Note1)
11: (Transmit:00H, Receive:Ignored)

Note1: For information about the relationship between setting values and send/receive values, see the “33.1 Off/On Setting Value Table” in “VIII Setting Values and Send/Receive Values” of this document.

Transmit Sent when a mixer part on/off setting is changed.

Receive Receipt changes the mixer part on/off setting.

7.25.2 Stage Setup Number Select

Message Format: BnH 62H 00H
 BnH 63H 24H
 BnH 06H mmH
 BnH 26H 11H

n: MIDI Channel Number
mm: Value (00H - 63H)
ll:

Transmit Sent when the stage setup number is changed while Stage Set.Chg is NRPN by Instrument settings.

Receive Receipt while Stage Set.Chg is NRPN by Instrument settings changes the stage setup number.

7.25.3 DSP Bypass

Message Format: BnH 62H 01H
 BnH 63H 22H
 BnH 06H mmH
 BnH 26H 11H

n: MIDI Channel Number
mm: Value (Note1)
ll: (Transmit:00h, Receive:Ignored)

Transmit Sent when the DSP Bypass on/off setting is changed.

Receive Receipt changes the DSP Bypass on/off setting.

Note1: For information about the relationship between setting values and send/receive values, see the “33.2 DSP Bypass Setting Value Table” in “VIII Setting Values and Send/Receive Values” of this document.

7.25.4 DSP Parameter

DSP parameters can be changed by NRPN. The relationship between each parameter and NRPN numbers is shown below.

Parameter	MSB	LSB	Notes
DSP Parameter [1]	23H	00H	
DSP Parameter [2]	23H	01H	
:	:	:	
DSP Parameter [16]	23H	0FH	

For details about each DSP parameter, see "VII DSP Parameter List".

7.25.5 Tone

Tone parameters can be changed by NRPN. The relationship between each parameter and NRPN numbers is shown below.

Tone Common Edit

Parameter	MSB	LSB	Notes
Volume	3FH	00H	
Reverb Send	3FH	01H	
Chorus Send	3FH	02H	
Delay Send	3FH	03H	
Dynamic Panning	3FH	10H	Note1

Note1: For information about the relationship between setting values and send/receive values, see "33.1 Off/On Setting Value Table" in "VIII Setting Values and Send/Receive Values" of this document.

Non-drum Tone Edit In the case of non-hex layer tones, setting values are applied in relation to reference values possessed by tones. In the case of hex layer tones, setting values are basically applied as absolute values. However, drum tones are not applied when they are received.

Parameter	MSB	LSB	Notes
LFO Pitch Rate	01H	08H	
LFO Pitch Depth	01H	09H	Note1
LFO Pitch Delay	01H	0AH	
Filter Cutoff	01H	20H	Note2
Filter Resonance	01H	21H	Note2
Amp&Filter Attack Time	01H	63H	Note2
Amp&Filter Decay Time	01H	64H	Note2,Note3
Amp&Filter Release Time	01H	66H	Note2,Note4

Note1: For a hex layer tone, for information about the relationship between setting values and send/receive values, see "33.25 -128 - 0 - +127 Setting Value Table" in "VIII Setting Values and Send/Receive Values" of this document.

Note2: For a hex layer tone, the values of all layers are changed.

Note3: For a hex layer tone, the values of Decay 1, 2, and 3 Time are changed.

Note4: For a hex layer tone, the values of Release 1 and 2 Time are changed.

Hex Layer Edit

Parameter	MSB	LSB	Notes
Layer On/Off	5XH	00H	Note1
Octave Shift	5XH	01H	Note2
Pitch LFO Depth	5XH	02H	
Filter LFO Depth	5XH	03H	
Amp Volume	5XH	04H	
Amp Pan	5XH	05H	Note3
Amp LFO Depth	5XH	06H	
DSP On/Off	5XH	07H	Note1

Note: X 0 through 5 correspond respectively to Layers 1 through 6.

Note1: For information about the relationship between setting values and send/receive values, see “33.1 Off/On Setting Value Table” in “VIII Setting Values and Send/Receive Values” of this document.

Note2: For information about the relationship between setting values and send/receive values, see “33.28 Octave Shift Setting Value Table” in “VIII Setting Values and Send/Receive Values” of this document.

Note3: For information about the relationship between setting values and send/receive values, see “33.5 Pan Setting Value Table” in “VIII Setting Values and Send/Receive Values” of this document.

Hex Layer Detune

Parameter	MSB	LSB	Notes
Detune	56H	00H	Note1

Note1: For information about the relationship between setting values and send/receive values, see “33.27 Hex Layer Detune Setting Value Table” in “VIII Setting Values and Send/Receive Values” of this document.

Drum Inst Edit Setting values are applied in relation to reference values possessed by tones.

Parameter	MSB	LSB	Notes
Filter Cutoff	14H	XXH	
Filter Resonance	15H	XXH	
Amp&Filter Attack Time	16H	XXH	
Amp&Filter Decay Time	17H	XXH	
Coarse Tune	18H	XXH	
Fine Tune	19H	XXH	Note1
Volume	1AH	XXH	
Pan	1CH	XXH	
Reverb Send	1DH	XXH	
Chorus Send	1EH	XXH	
Delay Send	1FH	XXH	

Note: XX 00 through 7F correspond respectively to Inst C- through G9.

Note1: For information about the relationship between setting values and send/receive values, see “33.26 -256 - 0 - +255 Setting Value Table” in “VIII Setting Values and Send/Receive Values” of this document.

7.26 RPN (64H,65H)

Message Format: BnH 64H 11H (LSB)
 BnH 65H mmH (MSB)

n: MIDI Channel Number
 11: LSB Value
 mm: MSB Value

7.26.1 Pitch Bend Sensitivity

Message Format: BnH 64H 00H
 BnH 65H 00H
 BnH 06H mmH
 BnH 26H 11H

n: MIDI Channel Number
mm: MSB Value(00H - 18H)
ll: LSB Value(Transmit:00H, Receive:Ignored)

Transmit Sent when Bend Range of any part is changed.

Receive Receipt changes Bend Range of the corresponding part.

7.26.2 Fine Tune

Message Format: BnH 64H 01H
 BnH 65H 00H
 BnH 06H mmH
 BnH 26H 11H

n: MIDI Channel Number
mm: MSB Value
ll: LSB Value

Transmit Sent when the fine tune of any part is changed.

Receive Receipt changes the fine tune of the corresponding part.

7.26.3 Coarse Tune

Message Format: BnH 64H 02H
 BnH 65H 00H
 BnH 06H mmH
 BnH 26H 11H

n: MIDI Channel Number
mm: MSB Value(28H - 58H)
ll: LSB Value(Transmit:00H, Receive:Ignored)

Transmit Sent when the coarse tune of any part is changed.

Receive Receipt changes the coarse tune of the corresponding part. Does not affect sound source operation when the Timbre Type (see “About the Timbre Type” in “8 Program Change”) is Drum.

7.26.4 Null

Message Format: BnH 64H 7FH
 BnH 65H 7FH

n: MIDI Channel Number

Transmit Sent when an RPN, NRPN message send operation is performed.

Receive Receipt de-selects RPN, NRPN.

7.27 All Sound Off (78H)

Message Format: BnH 78H 00H

n: MIDI Channel Number

Receive Receipt stops all voices that are sounding.

7.28 Reset All Controllers (79H)

Message Format: BnH 79H 00H

n: MIDI Channel Number

Transmit Sent when MIDI send related settings are changed.

Receive Receipt initializes each performance controller.

7.29 All Notes Off (7BH)

Message Format: BnH 7BH 00H

n: MIDI Channel Number

Transmit Sent when MIDI send related settings are changed.

Receive Receipt releases (key release) all voices that are sounding.

7.30 Omni Off (7CH)

Message Format: BnH 7CH 00H

n: MIDI Channel Number

Receive Receipt performs the same operation as when All Notes Off is received.

7.31 Omni On (7DH)

Message Format: BnH 7DH 00H

n: MIDI Channel Number

Receive Receipt performs the same operation as when All Notes Off is received.

7.32 Mono (7EH)

Message Format: BnH 7EH 00H

n: MIDI Channel Number

Receive Receipt performs the same operation as when All Notes Off is received.

7.33 Poly (7FH)

Message Format: BnH 7FH 00H

n: MIDI Channel Number

Receive Receipt performs the same operation as when All Notes Off is received.

8 Program Change

Message Format: CnH ppH

n: MIDI Channel Number

pp: Program Number (Note1)

Note1: For details about the relationship between the program number and the tone, see the Tone List that comes with the Instrument.

Transmit Sent when a tone or stage setup number is selected.

Receive Receipt changes the ton of the corresponding part. The selected tone is determined by the program value of this message and the Bank Select message value received prior to this message. Also note that receipt of this message also may change the Timbre Type that corresponds to the selected tone. For more information, see “About the Timbre Type” below.

The stage setup number can also be changed by the bank program. For details, see “Stage Setup Number Switching by Bank Select Message and Program Change Message” below.

About the Timbre Type Tones that are selected by each Instrument part have an attribute that depends on the sound source operation type. This attribute is called the “timbre type,” which is one of the types described below.

- Melody

This timbre type optimizes for normal melody tones. The damper pedal performs on/off operations.

- Piano

This Timbre Type is for piano tones. The decay rate of the voice being sounded is seamlessly altered in accordance with the damper pedal position. The method for producing sound in response to the note messages also is different from that of the melody Timbre Type, and operation is optimized for piano.

- LMPiano

This Timbre Type is for Linear Morphing piano tones. The decay rate of the voice being sounded and Damper Resonance effect characteristics are seamlessly altered in accordance with the damper pedal position. The method for producing sound in response to the note messages also is different from that of the melody Timbre Type, and operation is optimized for piano.

- Drum

This setting optimizes for drum sounds. The damper pedal does not function. The Hold1, Channel Coarse Tune, and Master Coarse Tune messages are ignored if they are received.

- Hex Layer

This setting optimizes for hex layer tones. The damper pedal performs on/off operations.

Stage Setup Number Switching by Bank Select Message and Program Change Message

The bank select message and program change message can be used to switch the stage setup number. The change target can be switched by the bank select MSB. The change target is specified by the program change number. The bank select LSB is ignored.

Change Target	Bank Select MSB
Stage Setup	70H

When Stage Set.Chg NRPN is enabled by Instrument settings, number switching by bank select and program change is ignored. For details about stage setups, see the Instrument's User's Guide.

9 Channel After Touch

Message Format: DnH vvH

n: MIDI Channel Number
 vv: Value

Receive Receipt adds, to the tone being sounded, modulation of a depth specified by the value. In the case of a tone that already has modulation applied, receipt of this message increases the modulation depth. The modulation effect differs according to the tone being used.

10 Pitch Bend

Message Format: EnH llH mmH

n: MIDI Channel Number
 ll: Value LSB
 mm: Value MSB

Transmit Sent when the bender is operated.

Receive Receipt changes the pitch of the currently sounding note. The range of the pitch change depends on the Bend Range value setting.

Part III

System Message

11 Timing Clock

Message Format: F8H

Transmit Sent periodically when the MIDI sync mode is master.

Receive Receipt while the MIDI sync mode is slave causes tempo to be synced based in timing clock information.

12 Start

Message Format: FAH

Transmit Sent when the Song Sequencer is started while the MIDI sync mode is master.

Receive Receipt while the MIDI sync mode is slave starts Auto Accompaniment play upon receipt of the next sent timing clock (F8H).

13 Continue

Message Format: FBH

Transmit Sent when the Song Sequencer playback is started while the MIDI sync mode is master.

Receive Receipt while the MIDI sync mode is slave cancels temporary Auto Accompaniment play stop.

14 Stop

Message Format: FCH

Transmit Sent when Song Sequencer is stopped while the MIDI sync mode is master.

Receive Receipt while the MIDI sync mode is slave stops Auto Accompaniment play.

15 Active Sensing

Message Format: FEH

Transmit Sent periodically when the MIDI sync mode is master.

Receive Once this message is received, the Active Sensing mode is entered. If no MIDI message is received for a specified amount of time, voices being sounded by this Instrument's sound source are released, the controller is reset, and the Active Sensing mode is exited.

16 System Exclusive Message

Message Format: FOH iiH ddH...F7H

ii: ID Number

dd: Device ID

The Instrument sends and receives standard universal system exclusive messages, and system exclusive messages that have Instrument-specific formats.

ID Number The ID numbers handed by this Instrument are shown below.

ID Number ID Name

44H Casio Computer Co. Ltd

7EH Non Real Time System Exclusive Message

7FH Real Time System Exclusive Message

Device ID The device ID is used mainly for individual control of multiple devices. When a System Exclusive message is sent, the sending device sends messages that include a value that matches the device ID of the sending device. When a System Exclusive message is received, the receiving device receives only messages that include a value that matches the receiving device ID.

The device ID 7FH is a special value, and receipt is always performed whenever the device ID of either the receiving device or the message is 7FH.

Settings can be configured to change the Instrument's device ID.

16.1 Universal Real Time System Exclusive Message

Message Format: FOH 7FH ddH...F7H

dd: Device ID

16.1.1 Master Volume

Message Format: FOH 7FH ddH 04H 01H 11H mmH F7H

dd: Device ID

11: LSB Value(Receive:Ignored)

mm: MSB Value

Transmit Sent when the Master Volume is changed.

Receive Receipt changes the Master Volume.

16.1.2 Master Fine Tuning

Message Format: F0H 7FH ddH 04H 03H 11H mmH F7H

dd: Device ID
11: LSB Value(Note1)
mm: MSB Value(Note1)

Note1: For information about the relationship between setting values and send/receive values, see “33.6 Fine Tuning Setting Value Table” in “VIII Setting Values and Send/Receive Values” of this document.

Transmit This message is sent when the tuning setting is changed.

Receive Receipt changes the tuning setting.

16.1.3 Master Coarse Tuning

Message Format: F0H 7FH ddH 04H 04H 11H mmH F7H

dd: Device ID
11: LSB Value(Transmit:00H,Receive:Ignored)
mm: MSB Value(28H - 58H)

Transmit This message is sent when the Master Coarse Tune setting is changed.

Receive Receipt changes the Patch Master Coarse Tune parameter.

16.1.4 Reverb Type

Message Format: F0H 7FH ddH 04H 05H 01H 01H 01H 01H 01H 00H vvH F7H

dd: Device ID
vv: Value(Note1)

Note1: For information about the relationship between setting values and send/receive values, see “33.7 Reverb Type Setting Value Table” in “VIII Setting Values and Send/Receive Values” of this document.

Receive Receipt changes the reverb type.

16.1.5 Reverb Time

Message Format: F0H 7FH ddH 04H 05H 01H 01H 01H 01H 01H 01H vvH F7H

dd: Device ID
vv: Value

Receive Receipt changes the Reverb duration.

16.1.6 Chorus Type

Message Format: F0H 7FH 7FH 04H 05H 01H 01H 01H 01H 02H 00H vvH F7H

dd: Device ID
vv: Value(Note1)

Note1: For information about the relationship between setting values and send/receive values, see “33.8 Chorus Type Setting Value Table” in “VIII Setting Values and Send/Receive Values” of this document.

Receive Receipt changes the chorus type.

16.1.7 Modulation Rate

Message Format: F0H 7FH ddH 04H 05H 01H 01H 01H 01H 02H 01H vvH F7H

dd: Device ID
vv: Value

Receive Receipt changes the Chorus Rate.

16.1.8 Modulation Depth

Message Format: F0H 7FH ddH 04H 05H 01H 01H 01H 01H 02H 02H vvH F7H

dd: Device ID
vv: Value

Receive Receipt changes the chorus level setting.

16.1.9 Send To Reverb

Message Format: F0H 7FH ddH 04H 05H 01H 01H 01H 01H 02H 04H vvH F7H

dd: Device ID
vv: Value

Receive Receipt changes the Chorus Sent To Reverb setting.

16.2 Universal Non Real Time System Exclusive Message

Message Format: F0H 7EH ddH...F7H

dd: Device ID

16.2.1 GM System On

Message Format: F0H 7EH ddH 09H 01H F7H

dd: Device ID

Receive Receipt puts the sound source into a GM sound source mode.

16.2.2 GM System Off

Message Format: F0H 7EH ddH 09H 02H F7H

dd: Device ID

Receive Receipt changes the sound source setting to the Instrument presetting.

16.2.3 GM2 System On

Message Format: F0H 7EH ddH 09H 03H F7H

dd: Device ID

Receive Though the Instrument does not support GM2, receipt of the GM2 System On message has the same result as receipt of the GM System On message.

16.3 Instrument-Specific System Exclusive Message

Message Format: F0H 44H ... F7H

This message can be used to send the Instrument memory status, for two-way transfer of special operation commands and user data, to perform sound source parameter operations, etc. For more information, see “IV Instrument-Specific System Exclusive Messages”.

Part IV

Instrument-Specific System Exclusive Messages

17 Format

This section explains the format of the Instrument-specific System Exclusive Messages. See “V Parameter List” and “VI Parameter Set List” for information about how parameter sets actually are transferred.

17.1 Message Classifications

Basically, the operation that corresponds to Instrument-specific system exclusive messages is parameter data transfer.

The following operations can be performed from an external device using this parameter transfer message.

- Modification of an individual Instrument parameter
- Batch modification of a particular Instrument parameter set
- Import of an individual Instrument parameter value
- Batch import of a particular Instrument parameter set

In addition to parameters being used as device setting values, some parameters act as commands when received by the Instrument and as device status information when sent from the Instrument.

The following table shows the parameter category for each type of transfer.

Function Section	Parameter Category	Description
System	System	Commands to the Instrument, Instrument stats
	ArpeggioDir	Arpeggio data directory information
	PhraseDir	Phrase data directory information
	SongDir	Song data directory information
Performance Controller	Spec	Global settings, settings of each music engine
Sound Generator	Patch	Sound source common settings (system effects, master settings, etc.) Instrument part settings (tone selection, mixer channel setting, tuning, etc.)
	Tone	Tone common settings
	Drum	Drum Setting
	Hex Layer	Hex Layer Setting

17.2 Basic Message Structure

Instrument-specific system exclusive message operation can be broadly divided between two methods: Individual Parameter Transfer (single parameter send/receive) and Bulk Parameter Set Transfer (batch parameter send/receive). Each method includes a number of different messages.

The field in the system exclusive message that specifies the message type is the action (*act*) field. The format of the *body* part of the message depends on the *act* value.

The table below shows the body format for each action of Instrument-specific system exclusive messages. An actual message consists of the items indicated by Y, from left to right.

					<-	<i>body</i> (Depends on <i>act</i>)										->	
	SX	MAN	MOD	<i>dev</i>	<i>act</i>	<i>cat</i>	<i>mem</i>	<i>pset</i>	<i>blk</i>	<i>prm</i>	<i>idx</i>	<i>len</i>	<i>data</i>	<i>img</i>	<i>crc</i>	EOX	
IPR	Y	Y	Y	Y	Y	Y	Y	Y	Y	Y	Y	Y	-	-	-	Y	
IPS	Y	Y	Y	Y	Y	Y	Y	Y	Y	Y	Y	Y	Y	-	-	Y	
OBR	Y	Y	Y	Y	Y	Y	Y	Y	-	-	-	-	-	-	-	Y	
OBS	Y	Y	Y	Y	Y	Y	Y	Y	-	-	-	Y	-	Y	Y	Y	
HBR	Y	Y	Y	Y	Y	Y	Y	Y	-	-	-	-	-	-	-	Y	
HBS	Y	Y	Y	Y	Y	Y	Y	Y	-	-	-	Y	-	Y	Y	Y	
EXI	Y	Y	Y	Y	Y	-	-	-	-	-	-	-	-	-	-	Y	
SBS	Y	Y	Y	Y	Y	-	-	-	-	-	-	-	Y	-	-	Y	
ACK	Y	Y	Y	Y	Y	Y	Y	Y	-	-	-	-	-	-	-	Y	
RJC	Y	Y	Y	Y	Y	Y	Y	Y	-	-	-	-	-	-	-	Y	
ESS	Y	Y	Y	Y	Y	Y	Y	Y	-	-	-	-	-	-	-	Y	
EBS	Y	Y	Y	Y	Y	Y	Y	Y	-	-	-	-	-	-	-	Y	
ERR	Y	Y	Y	Y	Y	-	-	-	-	-	-	-	Y	-	-	Y	

17.3 Format of Each Field

17.3.1 SX : System Exclusive message Status

Format: 11110000B (F0H)

This is the System Exclusive Message status byte established by the MIDI standard.

17.3.2 MAN : Manufacturer's ID

Format: 01000100B (CASIO = 44H)

Indicates this Instrument's manufacturer ID.

17.3.3 MOD : Model ID

Format: MSB 00010111B (17H)
 LSB 00000010B (02H)

These two successive bytes (MSB, LSB) indicate the PX-5S model ID.

17.3.4 *dev* : MIDI Device ID 00H - 7FH

Format: 0dddddddB

The contents of this field in a received message are compared with the Model's MIDI Device ID, and receipt of the incoming message is allowed only when the two IDs match. When a message containing 7FH is received, receipt of the message is always allowed, regardless of the Instrument's ID setting.

17.3.5 *act* : Action

Format: 0aaaaaaaaB

This field indicates the operation of the Instrument-specific System Exclusive Message.

aaaaaaaaB	Action	Function
00H	IPR	Individual Parameter Request
01H	IPS	Individual Parameter Send
02H	OBR	One-way Bulk Parameter Set Request
03H	OBS	One-way Bulk Parameter Set Send
04H	HBR	Handshake Bulk Parameter Set Request
05H	HBS	Handshake Bulk Parameter Set Send
08H	SBS	Start of Bulk Dump Session Session
09H	EXI	Extend Interval
0AH	ACK	Acknowledge
0BH	RJC	Reject
0DH	ESS	End of Sub-session
0EH	EBS	End of Bulk Dump Session
0FH	ERR	Error

IPR:Individual Parameter Request Indicates an individual parameter value send request message. When the Instrument receives this action, it uses an IPS message to return the specified parameter value.

IPS:Individual Parameter Send Indicates an individual parameter value send message. When the Instrument receives this action, it rewrites the value specified by the *data* field with the specified parameter value.

OBR:One-way Bulk Parameter Set Request Indicates a send request message using parameter set image one-way mode. When the Instrument receives this action, it uses an OBS message to return the specified parameter set.

OBS:One-way Bulk Parameter Set Bulk Send Indicates a parameter set image send message using one-way mode. When the parameter set to be transferred is greater than a preset size, it is divided into multiple packets and transferred at prescribed time intervals. The time interval is set in accordance with the Oneway Current Interval parameter described under “21.3 Data Management Parameter”.

HBR:Handshake Bulk Parameter Set Request Indicates a send request message using the parameter set image handshake mode. When the Instrument receives this action, it uses an HBS message to return the specified parameter set.

HBS:Handshake Bulk Parameter Set Send Indicates a parameter set image send message using handshake mode. The parameter set to be transferred is divided into multiple packets when it is greater than a prescribed size. The packets are transferred in accordance with handshake mode.

EXI:Extend Interval During a dump session, message sent by a devices that should send the next message to tell a device waiting for the next message to extend the message interval. Receipt of this message causes the message wait elapsed time to reset to 0.

SBS:Start of Bulk Dump Session This message is sent to both devices to start a session to transfer a series of parameter sets using one-way protocol or handshake protocol. The protocol used during the session and the data transfer direction is determined in accordance with the value of the data field. For details, see the explanation about the data field. When there is a request to start a handshake protocol session, the devices that receive this message return ACK after setting up to enable a session. This message is ignored if the outlook is that a session cannot be enabled.

ACK:Acknowledge Indicates a message used by the receiver during parameter set handshake mode transfer to convey to the sender that it is ready for send of the next packet. The *cat*, *mem*, and *pset* fields indicate the value carried by the last received message.

RJC:Reject Indicates a message to convey to the other side that an ongoing parameter set one-way mode or handshake mode send or receive session was interrupted. The *cat*, *mem*, and *pset* fields indicate the value carried by the last received message.

ESS:End of Sub-session Indicates there is a message to convey to the receiving device that a one-way mode or handshake mode serial packet transfer for sending a sub-session (one parameter set) is complete. The *cat*, *mem*, and *pset* fields indicate the values in the last received message.

EBS:End of Bulk Dump Session Indicates there is a message to convey to the receiving device that a one-way mode or handshake mode serial parameter set transfer session send, which was launched by some operation, is complete. The *cat*, *mem*, and *pset* fields indicate the values in the last received message.

ERR:Error This message is sent to a device that sent a message during a parameter set transfer session using handshake protocol bulk dump, when the device that received the message encounters some communication problem. The generated error type depends on the value in the data field. For details, see the explanation about the data field.

17.3.6 *cat* : Category

Format: 0ccccccB

The category indicates the categories of data handled by the System Exclusive Message. The ID number (ID) of the Category is indicated on the left, while the communication operation (Action) is indicated on the right.

Category		Transfer		
ID (c)	Parameter Set	Individual Parameter	One-way Bulk	Handshake Bulk
00H	System	A	–	–
02H	Patch	A	A	A
03H	Tone	A	A	A
06H	Drum	A	A	A
09H	Hex Layer	A	A	A
22H	ArpeggioDir	F	A	A
23H	PhraseDir	F	A	A
24H	SongDir	F	A	A
2AH	Spec	A	A	A

- A ... Available (Also including when only some parameters are available.)
- F ... File Information (Not the data itself. Name, size, and other file information only.)
- ... Not Available

17.3.7 *mem* : Memory Area ID

Format: 0mmmmmmB

Specifies the memory area that is the object of the parameter transfer. The following are defined for this Instrument. Instrument-specific System Exclusive messages basically correspond to the user area only.

mem	Data Type	Meaning
0	Preset area	Read/write disabled
1	User area	Read/write enabled

17.3.8 *pset* : Parameter Set Number

Format: LSB 0nnnnnnnB
MSB 0mmmmmmB

This field is a 2-byte (LSB, MSB) value indicating the number of the parameter set (mmmmmmnnnnnnB, Binary) being transferred.

17.3.9 *blk* : Block Number

The block number is a supplementary number that specifies which block parameter is to be accessed when there are multiple blocks (instrument parts, etc.) that include parameters with the same ID within a single parameter set. The array structure of a block can be expressed up to 4 dimensions, and the size of a 1-dimensional array is expressed as 14 bits.

Format: index3 LSB 0iiiiiiiB
index3 MSB 0jjjjjjB
index2 LSB 0kkkkkkkB
index2 MSB 0lllllllB
index1 LSB 0mmmmmmB
index1 MSB 0nnnnnnnB
index0 LSB 0ooooooB
index0 MSB 0pppppppB

Note: Arranged in high dimension sequence.

1-dimension array block [index0]

1-dimension array block [index0]

Value	Meaning
00jjjjjjjjiiiiiiiB	0000H
00llllllllkkkkkkkB	0000H
00nnnnnnnnmmmmmmB	0000H
00ppppppppooooooB	index0

2-dimension array block [index1][index0]

Value	Meaning
00jjjjjjjiiiiiiB	0000H
001111111kkkkkkkB	0000H
00nnnnnnnmmmmmmB	index1
00pppppppooooooB	index0

3-dimension array block [index2][index1][index0]

Value	Meaning
00jjjjjjjiiiiiiB	0000H
001111111kkkkkkkB	index2
00nnnnnnnmmmmmmB	index1
00pppppppooooooB	index0

4-dimension array block [index3][index2][index1][index0]

Value	Meaning
00jjjjjjjiiiiiiB	index3
001111111kkkkkkkB	index2
00nnnnnnnmmmmmmB	index1
00pppppppooooooB	index0

17.3.10 *prm* : Parameter ID

Format: LSB 0pppppppB
 MSB 0qqqqqqqB

The Parameter ID indicates the parameter type. When transferring parameters (see “V Parameter List” below) individually (as opposed to bulk transfer), this field is used to identify the parameter being transferred by its parameter ID.

17.3.11 *idx* : Data Index Number

Format: LSB 0iiiiiiiB
 MSB 0jjjjjjjB

The data index number indicates the first array number of the array from which transfer starts.

17.3.12 *len* : Data Length

Format: LSB 01111111B
 MSB 0mmmmmmB

As shown below, the meaning of this field differs depending on whether an individual transfer or a bulk parameter set transfer is being performed.

Individual Parameter Transfer The value of this field specifies the size of the parameter value stored in the data field. Data length indicates the length of the array being transferred minus 1 when the parameter contains a character string or other similar array structure.

Bulk Parameter Set Transfer The value of this field specifies the size of the parameter set memory image stored in the img field. Data length indicates the number of bytes of data included within a packet. When this value is zero, it means the data itself does not exist.

17.3.13 data : Parameter Data

Individual Parameter Transfer

```
Format:  index0  0dddddddB (0eeeeeeeB) (0ffffffB) (0gggggggB) (0hhhhhhhB)
         index1  0dddddddB (0eeeeeeeB) (0ffffffB) (0gggggggB) (0hhhhhhhB)
         index2  0dddddddB (0eeeeeeeB) (0ffffffB) (0gggggggB) (0hhhhhhhB)
         :      :
         indexN  0dddddddB (0eeeeeeeB) (0ffffffB) (0gggggggB) (0hhhhhhhB)
```

Parameter data indicates the parameter value. Data is repeatedly placed in an array of the size equivalent to len+1. For the structure of one data item, the length depends on the data bit width (Parameter List Size), as shown below.

Size	Number of Data
1 - 7	1
8 - 14	2
15 - 21	3
22 - 28	4
29 - 32	5

Each block of data is packed from the lowest order byte first. In the case of multiple-byte data, the lowest weighted bit is the least significant digit of the first data byte, and the highest weighted bit is the most significant digit of the final data byte. The following shows an example of how data would be divided for transfer in the case of 32-bit data.

	7	6	5	4	3	2	1	0
data0:	0	[bit06]	[bit05]	[bit04]	[bit03]	[bit02]	[bit01]	[bit00]
data1:	0	[bit13]	[bit12]	[bit11]	[bit10]	[bit09]	[bit08]	[bit07]
data2:	0	[bit20]	[bit19]	[bit18]	[bit17]	[bit16]	[bit15]	[bit14]
data3:	0	[bit27]	[bit26]	[bit25]	[bit24]	[bit23]	[bit22]	[bit21]
data4:	0	0	0	0	[bit31]	[bit30]	[bit29]	[bit28]

SBS (Start of Bulk Dump Session)

Format: 0bbbbbbbB

The relationship between the data value and error 0bbbbbbbB is defined as shown below.

- Data = 0 : Start OBR Session
Start session to request data using one-way protocol.
- Data = 1 : Start OBS Session
Start session to send data using one-way protocol.
- Data = 2 : Start HBR Session
Start session to request data using handshake protocol. If a device that receives this message accepts the session, it needs to return ACK.

- Data = 3 : Start HBS Session

Start session to send data using handshake protocol. If a device that receives this message accepts the session, it needs to return ACK.

ERR (Error)

Format: 00000000B

The relationship between the data value and error 00000000B is defined as shown below.

- Data = 0 : Time Out Error

This error message is generated when a preset amount of time elapses without a receiving device receiving an expected message. This error is also generated when an unexpected message is received instead of the expected message. The preset time is set in accordance with the Handshake Max Interval parameter described under “21.3 Data Management Parameter”.

- Data = 1 : Format Error

This error message is issued in the case of an invalid format in an Instrument System Exclusive message received by a receiving device.

- Data = 2 : CRC Error

This error message is issued in the case of an invalid CRC value in an HBS message received by the data receiving device.

Single Parameter Data Size Limit Under initial default settings for the Instrument’s System Exclusive message format, the size of a single message cannot exceed 256 bytes in the case of bulk dump using handshake protocol, and cannot exceed 48 bytes in all other cases. The data size and the array size, however, can cause a packet to exceed 48 bytes when transferring a single parameter array. In this case, the IPS and IPR message data length and data index number values can be modified to enable division of a single parameter value into multiple messages so it can be sent that way. These message sizes can be changed with the system parameter.

17.3.14 *img* : Parameter Set Memory Image

```
Format:  Data0  0aaaaaaaaB
          Data1  0bbbbbbbaB
          Data2  0ccccccbB
          Data3  0ddddcccB
          :      :
```

During data transfer, the memory image data of the parameter set to be sent is read sequentially in 1-byte units starting from the first address. That value is transformed starting from the lower bit to a 7-bit wide data string.

Example: 33-byte data transfer In the case of memory image transfer of the 33 bytes such as Table 1, for example, the transfer image is transformed to 38 bytes as shown in Table 2.

Table 1

	7	6	5	4	3	2	1	0
Memory data 00:	[00.7]	[00.6]	[00.5]	[00.4]	[00.3]	[00.2]	[00.1]	[00.0]
Memory data 01:	[01.7]	[01.6]	[01.5]	[01.4]	[01.3]	[01.2]	[01.1]	[01.0]
Memory data 02:	[02.7]	[02.6]	[02.5]	[02.4]	[02.3]	[02.2]	[02.1]	[02.0]
:								
Memory data 32:	[32.7]	[32.6]	[32.5]	[32.4]	[32.3]	[32.2]	[32.1]	[32.0]

(Bit M of the NNth byte is indicated at [NN.M].)

Table 2

	7	6	5	4	3	2	1	0
Send data 00:	0	[00.6]	[00.5]	[00.4]	[00.3]	[00.2]	[00.1]	[00.0]
Send data 01:	0	[01.5]	[01.4]	[01.3]	[01.2]	[01.1]	[01.0]	[00.7]
Send data 02:	0	[02.4]	[02.3]	[02.2]	[02.1]	[02.0]	[01.7]	[01.6]
:								
Send data 37:	0	0	0	[32.7]	[32.6]	[32.5]	[32.4]	[32.3]

Though transferred data always sequentially uses from bit 0 through bit 7, unused upper bit fields in the final transfer data are filled in with 0.

Parameter Set Packet Splitting When a parameter set is transferred, a single parameter set memory image can be split so it can fit into the preset transfer message size, and transferred as multiple packets. Even when a packet is split, the memory image must be transferred from the beginning in the sequence it is arranged without interruption. When sending a parameter set to the Instrument, the size of a System Exclusive message for a single packet must fit within a preset size. The parameter set memory image to be transferred can be split into 1-byte units, and it does not matter whether the length of each packet is different. When a packet receive error is generated, the sending device needs to resend, but the size of the packet sent does not necessarily need to be the same size as the packet sent when the error was generated. Even the sizes of parameter sets are small, using a single packet to send multiple parameter sets is not supported. With this Instrument, the data size, transfer time interval, and other communication parameters for split packets can be adjusted using the parameters described under “21.3 Data Management Parameter”. For details, see “21.3 Data Management Parameter.”

17.3.15 *crc* : Cyclic Redundancy Check

```
Format:  LSB  0aaaaaaaaB
          0bbbbbbbaB
          0ccccbbB
          0dddcccB
          MSB  0000dddB
```

CRC32 (in accordance with ISO 8802-3 or IEEE803.2 regulations) 32-bit value (dddddddccccccc-cbbbbbbbaaaaaaaB) calculated for the byte string from “MAN: Manufacturer’s ID” to the last byte of “img: Parameter Set Memory Image” is stored in this “*crc*: Cyclic Redundancy Check”. The receiving unit checks the value, and if it is not correct sends an error as a re-request.

17.3.16 EOX : End of System Exclusive Message

Format: 11110111B (F7H)

This is the End of System Exclusive Message status byte established by the MIDI standard.

18 Individual Parameter Operations

There are two parameter unit operations: Individual Parameter Transfer and Individual Parameter Request. For one session, in response to an IPR (Individual Parameter Request) from an external device, this Instrument returns an IPS (Individual Parameter Send) or the session is concluded when the external device or this Instrument spontaneously sends an IPS. If this Instrument received an IPS, the value of the applicable parameter is changed. Depending on the function of a parameter, Individual Parameter Send may be used to issue a command to the Instrument and Individual Parameter Request may be used to check Instrument status information.

Data Receiver	Data Sender	Operation
IPR		Send Request(Optional)
	IPS	Data Transfer

19 Parameter Set Transfer

19.1 Communication Modes

19.1.1 One-way and Handshake

In order to ensure maximum speed for bulk dumping of Parameter Sets, the data format is different from the data format used for Individual Parameter Send. Data is transferred as-is, using the Model's memory image. Parameter Sets can be transferred by bulk dump using the message exchange types described below.

- One-way mode Parameter Set send/receive
- One-way mode Parameter Set send request send/receive
- Handshake mode Parameter Set send/receive
- Handshake mode Parameter Set send request, receive rejected, error notification send/receive

With the one-way mode, the sending device sends data and ends the session without regard to the response of the receiving device. This mode is best for one-way transfers from a sequencer or similar device.

With the handshake mode, the sending device sends the data and then waits for a response from the receiving device before advancing to the next session. This is a high-speed mode in which there is no time wasted waiting.

See "VI Parameter Set List" for details about Instrument parameter sets.

19.1.2 Session and Subsession

Subsession "One subsession" refers to transfer of one parameter set. A subsession transfers one parameter set or a parameter set that has been divided into multiple packets for transfer, with ESS (End of Sub-session) at the end to terminate the send. Division of a parameter set into multiple packets is used when the size of the parameter set is greater than a prescribed size. The packet number in the packet index field indicates the sequential position of a packet relative to the other packets. A single packet cannot be used to transfer multiple small parameter sets. A parameter set delimiter always must be transferred as a packet delimiter.

Session “One session” refers to a series of processes that occur for one user operation. One subsession or multiple subsessions make up a session. The sender sends EBS (End of Bulk Dump Session) to end a session. Regardless of whether there is a single parameter set or multiple parameter sets being transferred, a bulk dump always takes the form of a session, never a subsession only.

19.2 One-way Mode Communication Flow

A single session starts when an external device, which wants to start communication for data send/receive using one-way protocol, sends an SBS (Start of Bulk Dump Session) message to this Instrument, which is its communication partner. The external device starts a request send using OBR or a data send using OBS. The sub session ends when one parameter set that needs to be transferred by the data send device is complete. After the send of all the parameter sets is complete, the external device that started the communication sends an EBS to inform the Instrument that the session is ended. The transfer messages of a single parameter set cannot exceed a preset size. To do this, messages are split into multiple packets that are less than the preset size, and transfer is performed according to a preset interval. The preset size and preset time are determined in accordance with the parameters described under “21.3 Data Management Parameter”.

19.2.1 Example: Sending Data from the Instrument to an External Device in Response to a Request from the External Device

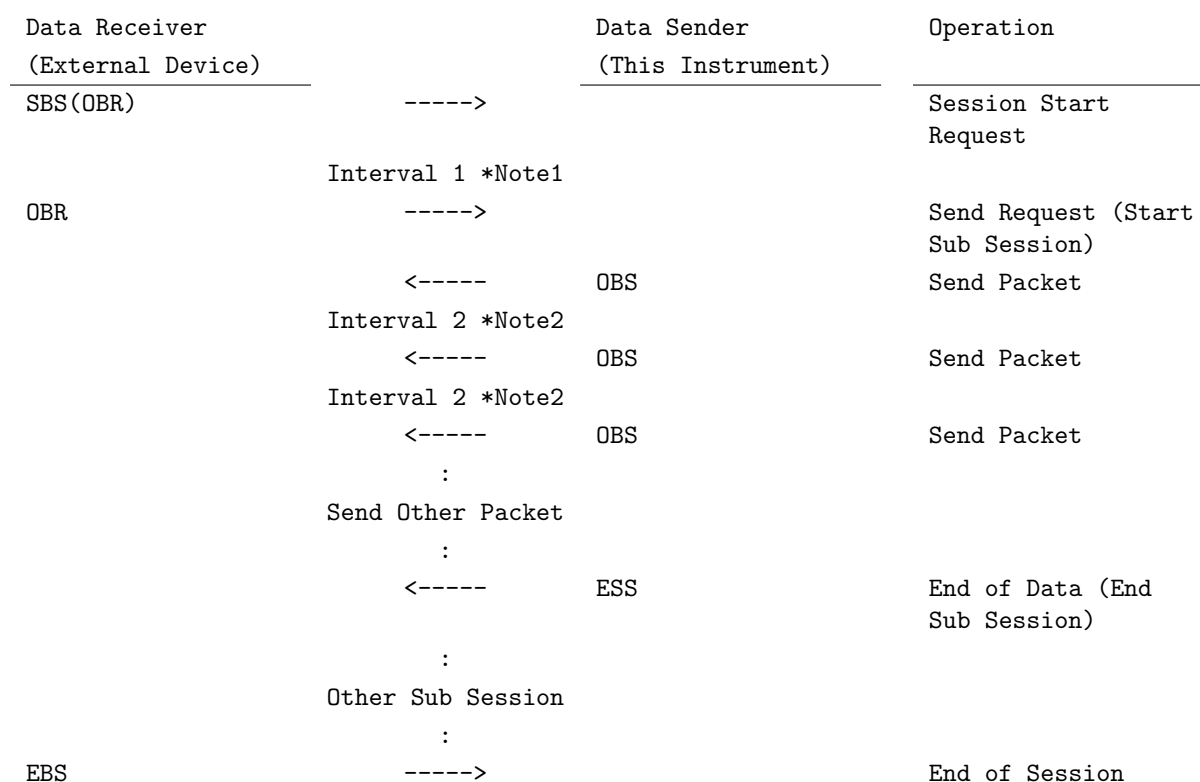

Note1: Interval 1 is no less than Oneway Min Interval and no more than Oneway Max Interval, which are explained under “21.3 Data Management Parameter”. If the interval exceeds these values, the partner device will issue a timeout error.

Note2: Interval 1 is a Oneway Current Interval, which is explained under “21.3 Data Management Parameter”.

19.2.2 Example: Data send to Instrument from external device

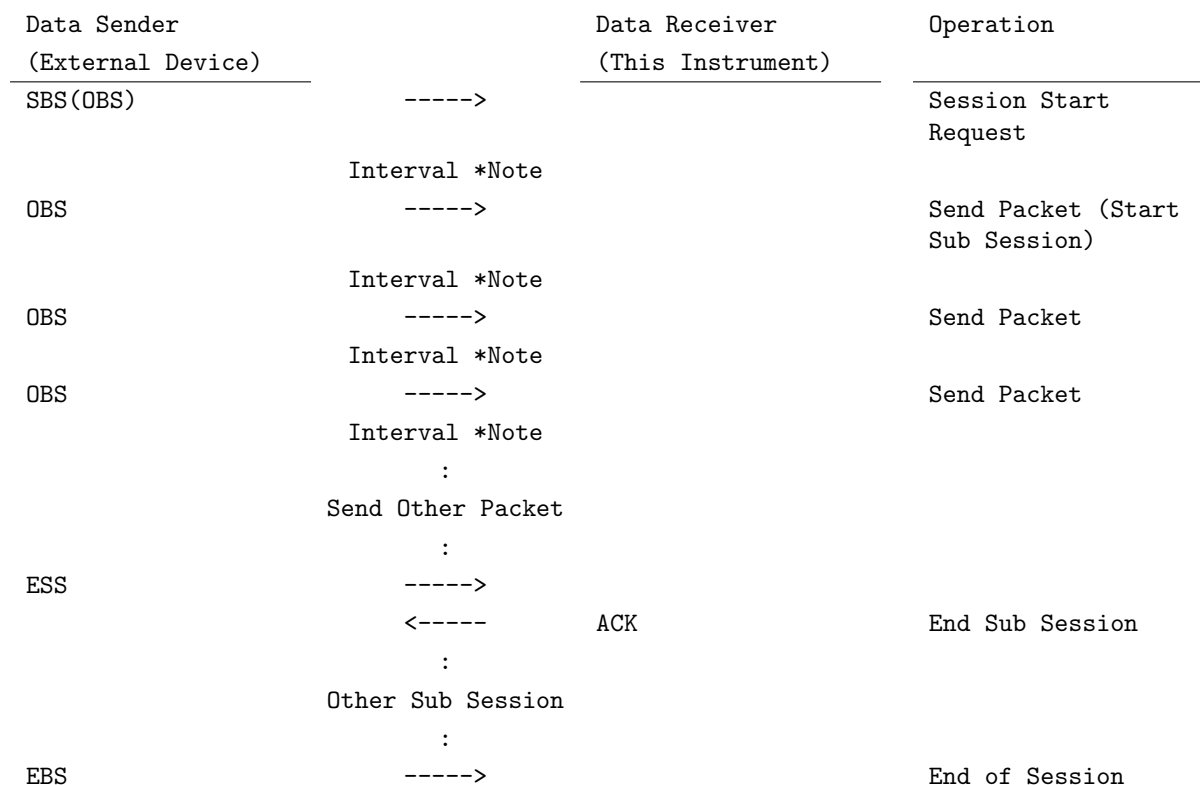

Note: The interval is no less than Oneway Min Interval and less than Oneway Max Interval, which are explained under “21.3 Data Management Parameter”. If the interval exceeds these values, the partner device will issue a timeout error.

19.3 Handshake Mode Communication Flow

19.3.1 Session Start

A single session starts when an external device, which wants to start communication for sending or receiving data using handshake protocol, sends an SBS (Start of Bulk Dump Session) message to this Instrument, which is its communication partner. The external device cannot send an HBS or HBR until this Instrument receives ACK.

19.3.2 Message Timeout Processing

Failure of the next message expected for receipt to arrive within a preset amount of time is viewed as a timeout error, and ERR (Data = Time Out Error) is sent to the partner device, which then returns to the message standby state. The device that received the ERR sends the message it believes the partner device that is in the message receive standby state. If the desired message does not arrive after a preset number of retries, RJC is sent and the session is terminated. The standby time and number of retries are determined in accordance with the parameters described under “21.3 Data Management Parameter”.

19.3.3 Message Format Error Processing

The message receive device returns ERR (Format Error) if it discovers an illegal format in the received message. When the message sending device receives ERR (Format Error) from the receiving device,

it resends the last data sent. If the correct message does not arrive after a preset number of retries, RJC is sent and the session is terminated. The number of retries is determined in accordance with the parameters described under “21.3 Data Management Parameter”.

19.3.4 Message CRC Error Processing

The message receive device returns ERR (CRC Error) if it discovers an illegal format in the received message. When the sending device receives ERR (CRC Error) from the receiving device, it resends the last data sent. If the correct CRC message does not arrive after a preset number of retries, RJC is sent and the session is terminated. The number of retries is determined in accordance with the parameters described under “21.3 Data Management Parameter”.

19.3.5 Processing when Multiple Errors are Generated

While communication retry is in progress following generation of a timeout error, format error, or CRC error, the retry count is not reset even if another error is generated. Also the error code of the last send error message is determined by the cause of the last error generated.

19.3.6 Session End

When the data send device is an external device, the session is concluded when the external device sends ESS and EBS in response to an ACK by this Instrument after the external device finishes sending all of the Parameter Sets that need to be transferred. When the data send device is an this Instrument, the session is concluded when the external device sends EBS after this Instrument finishes sending all of the Parameter Sets that need to be transferred. The maximum interval until one device sends a message following receipt of a message from another device is no greater than the Handshake Max Interval explained under “21.3 Data Management Parameter”. If the interval exceeds these values, the partner device will issue a timeout error.

19.3.7 Example: Sending Data from the Instrument to an External Device in Response to a Request from the External Device

Data Receiver (External Device)		Data Sender (This Instrument)	Operation
SBS(HBR)	----->		Session Start Request
	<-----	ACK	Acknowledge
HBR	----->		Send Request (Start Sub Session)
	<-----	HBS	Send Packet
ACK	----->		Acknowledge
	<-----	HBS	Send Packet
ACK	----->		Acknowledge
	<-----	HBS	Send Packet
ACK	----->		Acknowledge
	:		
	Send Other Packet		
	:		
ACK	----->		Acknowledge
	<-----	ESS	End Data (End Sub Session)
	:		
	Other Sub Session		
	:		
EBS	----->		End of Session

19.3.8 Example: Data send to Instrument from external device

Data Sender (External Device)		Data Receiver (This Instrument)	Operation
SBS(HBS)	----->		Session Start Request
	<-----	ACK	Acknowledge
HBS	----->		Send Packet
	<-----	ACK	Acknowledge
HBS	----->		Send Packet
	<-----	ACK	Acknowledge
HBS	----->		Send Packet
	<-----	ACK	Acknowledge
	:		
	Send Other Packet		
	:		
ESS	----->		End of Data
	:		
	Other Sub Session		
	:		
EBS	----->		End of Session

19.3.9 Example: Session Generating a Timeout Error

Data Receiver (External Device)		Data Sender (This Instrument)	Operation
SBS(HBR)	----->		Session Start Request
	Interval *Note1		
ERR(Time Out Error)	----->		Timeout Error
	<-----	ACK	Acknowledge
HBR	----->		Send Request (Optional)
	<-----	HBS	Send Packet
ACK	----->		Acknowledge
	Interval *Note1		
ERR(Time Out Error)	----->		Timeout Error
	Interval *Note1		
ERR(Time Out Error)	----->		2 consecutive timeout errors (Note2)
	<-----	HBS	Acknowledge
	Interval *Note1		
	<-----	ERR(Time Out Error)	Timeout Error
ACK	----->		Acknowledge
	<-----	HBS	Send Packet
	:		

Note1: Interval that exceeds the time stipulated by Handshake Max Interval explained under “21.3 Data Management Parameter”.

Note2: Number of retries that exceeds the retries stipulated by Handshake Max Retry explained under “21.3 Data Management Parameter”.

19.3.10 Example: Session Generating a Format Error

Data Receiver (External Device)		Data Sender (This Instrument)	Operation
SBS(HBR)	----->		Session Start Request
	<-----	ACK	Acknowledge
HBR	----->		Send Request (Optional)
	<-----	HBS	Send Packet
ACK	----->		Acknowledge
	<-???-	HBS	Send Packet (Note1)
ERR(Format Error)	----->		Format Error
	<-----	HBS	Resend Packet
ACK	-???->		Acknowledge
	<-----	ERR(Format Error)	Format Error
ACK	-???->		Acknowledge
	<-----	ERR(Format Error)	2 consecutive format errors(*Note2)
ACK	----->		Acknowledge
	<-----	HBS	Send Packet
		:	

Note1: “<-???-” or “-???->” indicates transfer failed.

Note2: Number of retries that exceeds the retries stipulated by Handshake Max Retry explained under “21.3 Data Management Parameter”.

19.3.11 Example: Session Generating a CRC Error

Data Receiver (External Device)		Data Sender (This Instrument)	Operation
SBS(HBR)	----->		Session Start Request
	<-----	ACK	Acknowledge
HBR	----->		Send Request (Optional)
	<-----	HBS	Send Packet
ACK	----->		Acknowledge
	<-???-	HBS	Send Packet
ERR(CRC Error)	----->		CRC error
	<-???-	HBS	Resend Packet
ERR(CRC Error)	----->		2 consecutive CRC errors(*Note)
	<-----	HBS	Resend Packet
ACK	----->		Acknowledge
	<-----	HBS	Send Packet
		:	

Note: Number of retries that exceeds the retries stipulated by Handshake Max Retry explained under “21.3 Data Management Parameter”.

19.3.12 Example: Session Termination by Error Generation

Data Receiver		Data Sender	Operation
SBS(HBR)	----->		Session Start Request
	<-----	ACK	Acknowledge
HBR	----->		Send Request (Optional)
	<-----	HBS	Send Packet
ACK	----->		Acknowledge
	<-???-	HBS	Send Packet
	<-???-	HBS	Send Packet
ERR(CRC Error)	----->		Error
	<-???-	HBS	Resend Packet
ERR(Format Error)	----->		2 consecutive errors
	<-???-	HBS	Resend Packet
ERR(Time Out Error)	----->		3 consecutive errors
	:		
	<-???-	HBS	Resend Packet
ERR(CRC Error)	----->		N consecutive errors(*Note)
	<-???-	HBS	Resend Packet
RJC	----->		Abandon Session

Note: Number of retries that exceeds the retries stipulated by Handshake Max Retry explained under “21.3 Data Management Parameter”. Also, the maximum number of retries is the same, even if multiple instances of the same error are generated or if multiple different errors are generated.

19.3.13 Example: Intentional Session Termination by an External Device

Data Receiver (External Device)		Data Sender (This Instrument)	Operation
SBS(HBR)	----->		Session Start Request
	<-----	ACK	Acknowledge
HBR	----->		Send Request
	<-----	HBS	Send Packet
ACK	----->		Acknowledge
	<-----	HBS	Send Packet
ACK	----->		Acknowledge
	<-----	HBS	Send Packet
RJC	----->		Terminate Session

19.3.14 Example: Intentional Session Termination by This Instrument

Data Sender (External Device)		Data Receiver (This Instrument)	Operation
SBS (HBS)	----->		Session Start Request
	<-----	ACK	Acknowledge
HBS	----->		Send Packet
	<-----	ACK	Acknowledge
HBS	----->		Send Packet
	<-----	ACK	Acknowledge
HBS	----->		Send Packet
	<-----	RJC	Terminate Session

19.3.15 Example: Session Pause

Session flow when the session is temporarily paused for some reason and then restarted is shown below. A session can be paused by sending an EXI message from an external device or this Instrument to the other device.

Data Receiver (External Device)		Data Sender (This Instrument)	Operation
SBS (HBR)	----->		Session Start Request
	<-----	ACK	Acknowledge
HBR	----->		Send Request
	<-----	HBS	Send Packet
ACK	----->		Acknowledge
	<-----	HBS	Send Packet
	Interval *Note1		
EXI	----->		Extend Interval (Pause Session)
	Interval *Note1		
EXI	----->		Extend Interval
	:		
EXI	----->		Extend Interval
	Interval *Note1		
ACK	----->		Acknowledge (Restart Session)*Note2
	<-----	HBS	Send Packet
ESS	----->		End of Data
	:		
	Other Sub Session		
	:		
EBS	----->		End of Session

Note1: Interval less than the time stipulated by Handshake Max Interval explained under “21.3 Data Management Parameter”. There is no limit on the number of extensions using EXI.

Note2: The sessions can be paused by sending RJC here.

Part V

Parameter List

This section explains the parameters that actually can be transferred by the Instrument.

20 Using the Parameter List

- Parameter field
Shows the parameter name.
- ID field
Shows the parameter ID as a hexadecimal number.
- R/W field
Shows “R” to indicate that an IPR (Individual Parameter Request) read operation (Read) is possible or “W” to indicate that an IPS (Individual Parameter Send) write operation is possible.
- Block field
Shows the bit field allocation of the block number. The bit field position is shown as a decimal format number.
- Size field
Shows the parameter bit width as a decimal format value.
- Array field
Shows the parameter array size as a hexadecimal value.
- Min-Def-Max field
Shows the minimum value, default value, and maximum value for parameter acquisition as a hexadecimal value.
- Description field
Explains the meaning of parameter values. Unless otherwise specified, setting values are all indicated in decimal format.

Note: Operation is not guaranteed for values other than those noted here.

21 System Parameter

These parameters make it possible for an external device to check the status of the Instrument and for an external device to command some operation of the Instrument.

21.1 System Information Parameter

This parameter is a container for system information.

Parameter	ID	R/W	Block	Size	Array	Min-Def-Max	Description
Model Name	0000	R	55-0:0	7	08	00-20-7F	Ascii Character PX-5S...“PX-5S”

21.2 System Version Information

These are system version information parameters.

Parameter	ID	R/W	Block	Size	Array	Min-Def-Max	Description
Release Version	0002	R	55-0:0	7	05	00-00-7F	Release Version Number

21.3 Data Management Parameter

These are information acquisition and operation command parameters for this Instrument's Data Manager PC application.

Parameter	ID	R/W	Block	Size	Array	Min-Def-Max	Description
Ps Category	00A7	W	55-0:0	7	01	00-00-7F	Specifies the category ID of the parameter set that corresponds to an operation
Ps Memory	00A8	W		7	01	00-00-7F	Specifies the memory ID of the parameter set that corresponds to an operation.
Ps Number	00A9	W		14	01	0000-0001-3FFF	Specifies the number of the parameter set that corresponds to an operation.
Current Ps Existence	00AF	R		1	01	00-00-01	Whether a parameter set exists in the specified category. 0...No 1...Yes
Current Ps Size	00B0	R		32	01	00000000-00000000-FFFFFFFF	Size of a parameter set in the specified category/number (bytes).
Current Ps Name	00B1	R		8	10	00-20-7F	Name of a parameter set in the specified category (ASCII characters).
Max Ps Size	00B2	R		32	01	00000000-00000000-FFFFFFFF	Maximum size of parameter sets in the specified category (bytes).
Area Size	00B3	R		32	01	00000000-00000000-FFFFFFFF	Maximum size (bytes) of parameter sets in specified category
Available Size	00B4	R		32	01	00000000-00000000-FFFFFFFF	Maximum size (bytes) writable to parameter sets in specified category/number
Free Size	00B5	R		32	01	00000000-00000000-FFFFFFFF	Current size (bytes) of parameter set free space in specified category
Max Ps Number	00B6	R		14	01	0000-0000-FFFF	Maximum number parameter sets in the specified category (bytes).

21.4 System Exclusive Protocol Parameter

These parameters are related to the System Exclusive message protocol.

Parameter	ID	R/W	Block	Size	Array	Min-Def-Max	Description
Enable	00B7	R	55-0:0	2	01	00-00-02	Specifies whether or not bulk session is enabled. 0...Disabled 1...Enabled 2...Bulk session in progress
Oneway Min Interval	00B8	R		14	01	0000-0014-3FFF	Minimum time interval time value (msec) between packets during One-way Bulk Dump receive by Instrument
Oneway Max Interval	00B9	R/W		14	01	0000-0800-3FFF	Maximum allowable message wait time (msec) during One-way Bulk Dump receive by Instrument
Oneway Current Interval	00BA	R/W		14	01	0000-0014-3FFF	Current time interval value between packets during One-way Bulk Dump send by Instrument
Oneway Max Data Length	00BB	R		14	01	0000-0080-3FFF	Maximum memory size value (bytes) of transfer data included in one packet during One-way Bulk Dump send/receive by Instrument

Parameter	ID	R/W	Block	Size	Array	Min-Def-Max	Description
Oneway Current Data Length	00BC	R/W		14	01	0000-0080-3FFF	Current memory size value (bytes) of transfer data included in one packet during One-way Bulk Dump send by Instrument
Handshake Max Interval	00BD	R/W		14	01	0000-0800-3FFF	Maximum allowable message wait time (msec) during Handshake Bulk Dump receive by Instrument
Handshake Max Data Length	00BE	R		14	01	0000-0080-3FFF	Maximum memory size value (bytes) of transfer data included in one packet during Handshake Bulk Dump send/receive by Instrument
Handshake Current Data Length	00BF	R/W		14	01	0000-0080-3FFF	Maximum memory size value (bytes) of transfer data included in one packet during Handshake Bulk Dump send by Instrument
Handshake Retry Number	00C0	R/W		7	01	00-03-7F	Number of retries after error generation during Handshake Bulk Dump send

22 Patch Parameter

The main function of patch parameters is to configure the settings of the sound source of a device.

22.1 Master EQ Parameter

These parameters configure the Master EQ settings.

Parameter	ID	R/W	Block	Size	Array	Min-Def-Max	Description
Low Freq	00A0	R/W	55-0:0	7	01	00-00-0C	0...200Hz
							1...400Hz
							2...800Hz
							3...50Hz
							4...63Hz
							5...80Hz
							6...100Hz
							7...125Hz
							8...160Hz
							9...250Hz
							10...315Hz
							11...500Hz
12...630Hz							
Low Gain	00A1	R/W		7	01	00-0C-18	-12 - 0 - +12
Mid1 Freq	00A2	R/W		7	01	00-00-13	0...1.0kHz
							1...1.3kHz
							2...1.6kHz
							3...2.0kHz
							4...2.5kHz
							5...3.2kHz
							6...4.0kHz
							7...5.0kHz
							8...100Hz
							9...125Hz
							10...160Hz
							11...200Hz
							12...250Hz
							13...315Hz
							14...400Hz
							15...500Hz
							16...630Hz
17...800Hz							
18...6.3kHz							
19...8.0kHz							
Mid1 Gain	00A3	R/W		7	01	00-0C-18	-12 - 0 - +12
Mid2 Freq	00A4	R/W		7	01	00-04-13	0...1.0kHz

Parameter	ID	R/W	Block	Size	Array	Min-Def-Max	Description
							1...1.3kHz
							2...1.6kHz
							3...2.0kHz
							4...2.5kHz
							5...3.2kHz
							6...4.0kHz
							7...5.0kHz
							8...100Hz
							9...125Hz
							10...160Hz
							11...200Hz
							12...250Hz
							13...315Hz
							14...400Hz
							15...500Hz
							16...630Hz
							17...800Hz
							18...6.3kHz
							19...8.0kHz
Mid2 Gain	00A5	R/W		7	01	00-0C-18	-12 - 0 - +12
High Freq	00A6	R/W		7	01	00-02-09	0...6.0kHz
							1...8.0kHz
							2...10kHz
							3...2.0kHz
							4...2.5kHz
							5...3.2kHz
							6...4.0kHz
							7...5.0kHz
							8...13kHz
							9...16kHz
High Gain	00A7	R/W		7	01	00-0C-18	-12 - 0 - +12
Input	00A8	R/W		7	01	00-4A-7F	0 - 127
Output	00A9	R/W		7	01	00-7F-7F	0 - 127

22.2 Master Tune Parameter

These parameters configure the Master Tuning settings.

Parameter	ID	R/W	Block	Size	Array	Min-Def-Max	Description
Master Fine Tune	0001	R/W	55-0:0	10	01	0000-0200-03FF	-100 - 0 - +99.8(cent) (1unit=100/512cent)
Master Coarse Tune	0002	R/W		7	01	00-40-7F	-24 - 0 - +24(semitone)

22.3 Master Mixer Parameter

These parameters configure the Master settings of the mixer.

Parameter	ID	R/W	Block	Size	Array	Min-Def-Max	Description
Master Volume	0003	R/W	55-0:0	7	01	00-7F-7F	0 - 127
Master Pan	0004	R/W		7	01	00-40-7F	-64 - 0 - +63
Chorus Return	0005	R/W		7	01	00-40-7F	0 - 127
Chorus To Delay	0006	R/W		7	01	00-00-7F	0 - 127
Chorus To Reverb	0007	R/W		7	01	00-00-7F	0 - 127
Reverb Return	0008	R/W		7	01	00-40-7F	0 - 127
Delay To Reverb	0009	R/W		7	01	00-00-7F	0 - 127
Delay Return	000A	R/W		7	01	00-40-7F	0 - 127
Compressor Position	000B	R/W		1	01	00-01-01	0...Pre EQ 1...Post EQ

22.4 Master Compressor Parameter

These parameters configure the Master Compressor settings.

Parameter	ID	R/W	Block	Size	Array	Min-Def-Max	Description
Threshold	00C0	R/W	55-0:0	7	01	00-04-7F	0 - 127
Ratio	00C1	R/W		7	01	00-00-7F	0 - 127
Level	00C2	R/W		7	01	00-35-7F	0 - 127
Attack	00C3	R/W		7	01	00-00-7F	0 - 127
Release	00C4	R/W		7	01	00-7F-7F	0 - 127

22.5 Part Parameter

Part parameters configure the settings of each musical instrument part.

Parameter	ID	R/W	Block	Size	Array	Min-Def-Max	Description
Part Enable	00E0	R/W	3-0:Part #	1	01	00-01-01	0...Off 1...On
Tone Number	00E1	R/W		14	01	0000-0000-3FFF	0 - 16383
Fine Tune	00E2	R/W		10	01	0000-0200-03FF	-100 - 0 - +99.8(cent)(1unit=100/512cent)
Coarse Tune	00E3	R/W		7	01	28-40-58	-24 - 0 - +24(semitone)
Resonance Enable	00E5	R/W		1	01	00-01-01	0...Disable 1...Enable
Resonance Return Level	00E6	R/W		7	01	00-40-7F	0 - 127
Volume	00E7	R/W		7	01	00-64-7F	0 - 127
Pan	00E9	R/W		7	01	00-40-7F	-64 - 0 - +63
Chorus Send	00EA	R/W		7	01	00-00-7F	0 - 127
Reverb Send	00EB	R/W		7	01	00-28-7F	0 - 127
Delay Send	00EC	R/W		7	01	00-00-7F	0 - 127
Bend Range	00ED	R/W		7	01	00-02-18	0 - 24
DSP Bypass	00EE	R/W		1	01	00-00-01	0...Off 1...On

22.6 System Chorus Parameter

These parameters are for configuring system chorus settings.

Parameter	ID	R/W	Block	Size	Array	Min-Def-Max	Description
Type	0050	R/W	55-0:0	7	01	00-01-03	0...Light Cho 1...Chorus 2...FB Chorus 3...Flanger
Rate	0051	R/W		7	01	00-03-7F	0 - 127
Depth	0052	R/W		7	01	00-13-7F	0 - 127
Feedback	0053	R/W		7	01	00-08-7F	0 - 127
Tone	0054	R/W		7	01	00-4F-7F	0 - 127
Delay Time	0056	R/W		7	01	00-75-7F	0 - 127

22.7 System Delay Parameter

These parameters are for configuring system delay settings.

Parameter	ID	R/W	Block	Size	Array	Min-Def-Max	Description
Time	0060	R/W	55-0:0	7	01	00-3A-7F	0 - 127
Ratio Center	0061	R/W		7	01	00-7F-7F	0 - 127
Ratio Left	0062	R/W		7	01	00-05-7F	0 - 127
Ratio Right	0063	R/W		7	01	00-05-7F	0 - 127
Level Center	0064	R/W		7	01	00-7F-7F	0 - 127
Level Left	0065	R/W		7	01	00-00-7F	0 - 127
Level Right	0066	R/W		7	01	00-00-7F	0 - 127
Feedback	0067	R/W		7	01	00-20-7F	0 - 127
High Damp	0068	R/W		7	01	00-7F-7F	0 - 127
Tempo Sync	0069	R/W		7	01	00-00-0A	0...Off 1...1/4 2...1/3 3...3/8

Parameter	ID	R/W	Block	Size	Array	Min-Def-Max	Description
							4...1/2
							5...2/3
							6...3/4
							7...1
							8...4/3
							9...3/2
							10...2

22.8 System Reverb Parameter

These parameters are for configuring system reverb settings.

Parameter	ID	R/W	Block	Size	Array	Min-Def-Max	Description
Type	0080	R/W	55-0:0	7	01	00-02-03	0...Room 1...Hall1 2...Hall2 3...Plate
Time	0081	R/W		7	01	00-40-7F	0 - 127
Early Reflection	0082	R/W		7	01	00-40-7F	0 - 127
High Damp	0083	R/W		7	01	00-67-7F	0 - 127
Tone	0084	R/W		7	01	00-65-7F	0 - 127

22.9 System Resonance Parameter

These parameters are for configuring system resonance settings.

Parameter	ID	R/W	Block	Size	Array	Min-Def-Max	Description
String Resonance Send	00C5	R/W	55-0:0	4	01	00-0F-0F	0 - 15
Damper Resonance Send	00C6	R/W		4	01	00-0F-0F	0 - 15
Damper Resonance Noise Enable	00C7	R/W		1	01	00-01-01	0...0ff 1...0n

22.10 Patch Etc Parameter

These parameters configure other patch settings.

Parameter	ID	R/W	Block	Size	Array	Min-Def-Max	Description
Stage Setting Name[16]	00F2	R/W	55-0:0	7	10	00-20-7F	Ascii Character
Tempo	010F	R/W		8	01	14-78-FF	20 - 255
Phrase Seq Number	0110	R/W		32	01	00000000-00000000-000003E7	0 - 999
Hammer Response	0111	R/W		4	01	00-02-07	0 - 7
Zone Enable	0112	R/W	1-0:Zone #	1	01	00-01-01	0...0ff 1...0n
Zone Key Range Low	0113	R/W		7	01	00-00-7F	0 - 127
Zone Key Range Hi	0114	R/W		7	01	00-7F-7F	0 - 127
Zone Velocity Range Low	0115	R/W		7	01	00-00-7F	0 - 127
Zone Velocity Range Hi	0116	R/W		7	01	00-7F-7F	0 - 127
Zone Bend Range Low	0117	R/W		7	01	00-02-18	0 - 24
Zone Bend Range Hi	0118	R/W		7	01	00-02-18	0 - 24
Zone Octave Shift	0119	R/W		7	01	3E-40-42	-2 - 0 - +2
Zone Transpose	011A	R/W		7	01	34-40-4C	-12 - 0 - +12
Zone Knob1 Enable	011B	R/W		1	01	00-01-01	0...0ff 1...0n
Zone Knob2 Enable	011C	R/W		1	01	00-01-01	0...0ff 1...0n
Zone Knob3 Enable	011D	R/W		1	01	00-01-01	0...0ff 1...0n
Zone Knob4 Enable	011E	R/W		1	01	00-01-01	0...0ff 1...0n
Zone Slider1 Enable	011F	R/W		1	01	00-01-01	0...0ff 1...0n

Parameter	ID	R/W	Block	Size	Array	Min-Def-Max	Description
Zone Slider2 Enable	0120	R/W		1	01	00-01-01	0...Off 1...0n
Zone Slider3 Enable	0121	R/W		1	01	00-01-01	0...Off 1...0n
Zone Slider4 Enable	0122	R/W		1	01	00-01-01	0...Off 1...0n
Zone Slider5 Enable	0123	R/W		1	01	00-01-01	0...Off 1...0n
Zone Slider6 Enable	0124	R/W		1	01	00-01-01	0...Off 1...0n
Zone Pedal1 Enable	0125	R/W		1	01	00-01-01	0...Off 1...0n
Zone Pedal2 Enable	0126	R/W		1	01	00-01-01	0...Off 1...0n
Zone Bender Enable	0127	R/W		1	01	00-01-01	0...Off 1...0n
Zone Wheel Enable	0128	R/W		1	01	00-01-01	0...Off 1...0n
Zone Arpeggio Enable	0129	R/W		1	01	00-01-01	0...Off 1...0n
Zone Phrase Enable	012A	R/W		1	01	00-01-01	0...Off 1...0n
Prog & Bank Out	012B	R/W		2	01	00-00-02	0...Off 1...Program Change Only 2...Program & Bank
BANK MSB	012C	R/W		7	01	00-00-7F	0 - 127
BANK LSB	012D	R/W		7	01	00-00-7F	0 - 127
Program Change	012E	R/W		7	01	00-00-7F	0 - 127
Arpeggio Target	012F	R/W		1	01	00-00-01	0...Arpeggio 1...Phrase
Phrase Original Key	0130	R/W		8	01	00-3C-80	0 - 128
Arpeggio Number	0131	R/W		8	01	00-00-C7	0 - 199
Phrase Number	0132	R/W		10	01	0000-0000-03E7	0 - 999
Arpeggio Hold	0139	R/W		32	01	00000000-00000000-00000002	0...Off 1...0n 2...Hold
Damper Resonance Noise Volume	0258	R/W		4	01	00-08-0F	0 - 0xF
MIDI Out Ch	013C	R/W	3-0:Part #	7	01	00-00-0F	0 - 15
MIDI Generator Out	013E	R/W		1	01	00-01-01	0...Off 1...0n
MIDI MIDI Out	013F	R/W		1	01	00-01-01	0...Off 1...0n
MIDI USB Out	0140	R/W		1	01	00-01-01	0...Off 1...0n

22.11 Pedal Parameter

These parameters configure pedal settings.

Parameter	ID	R/W	Block	Size	Array	Min-Def-Max	Description
Pedal On Rate	0142	R/W	0:Pedal #	7	01	00-7F-7F	0 - 127
Pedal Off Rate	0144	R/W		7	01	00-7F-7F	0 - 127
Target	0145	R/W	0:Pedal # 14:Target #	8	01	00-00-FF	0 - 185 Target Type
Parameter Min	0147	R/W		7	01	00-00-7F	0 - 127
Parameter Max	0148	R/W		7	01	00-7F-7F	0 - 127
RPN/NRPN MSB	0149	R/W		7	01	00-00-7F	0 - 127
RPN/NRPN LSB	014A	R/W		7	01	00-00-7F	0 - 127
Data Entry MSB/LSB	014B	R/W		1	01	00-00-01	0...Data MSB 1...Data LSB
Pedal Toggle Flag	014C	R/W		1	01	00000000-00000000-00000001	0...Momentary 1...Toggle

22.12 Controller Parameter

These parameters configure controller settings.

22.12.1 Knob Parameter

Parameter	ID	R/W	Block	Size	Array	Min-Def-Max	Description
Target	00F4	R/W	1-0:Knob # 14:Target #	8	01	00-00-FF	0 - 185 Target Type
Parameter Min	00F6	R/W		7	01	00-00-7F	0 - 127
Parameter Max	00F7	R/W		7	01	00-7F-7F	0 - 127
RPN/NRPN MSB	00F8	R/W		7	01	00-00-7F	0 - 127
RPN/NRPN LSB	00F9	R/W		7	01	00-00-7F	0 - 127
Data Entry MSB/LSB	00FA	R/W		1	01	00-00-01	0...Data MSB 1...Data LSB

22.12.2 Modulation Parameter

Parameter	ID	R/W	Block	Size	Array	Min-Def-Max	Description
Target	0106	R/W	0:Target #	8	01	00-00-FF	0 - 185 Target Type
Parameter Min	0108	R/W		7	01	00-00-7F	0 - 127
Parameter Max	0109	R/W		7	01	00-7F-7F	0 - 127
RPN/NRPN MSB	010A	R/W		7	01	00-00-7F	0 - 127
RPN/NRPN LSB	010B	R/W		7	01	00-00-7F	0 - 127
Data Entry MSB/LSB	010C	R/W		1	01	00-00-01	0...Data MSB 1...Data LSB

22.12.3 Slider Parameter

Parameter	ID	R/W	Block	Size	Array	Min-Def-Max	Description
Target	00FD	R/W	2-0:Slider # 14:Target #	8	01	00-00-FF	0 - 185 Target Type
Parameter Min	00FF	R/W		7	01	00-00-7F	0 - 127
Parameter Max	0100	R/W		7	01	00-7F-7F	0 - 127
RPN/NRPN MSB	0101	R/W		7	01	00-00-7F	0 - 127
RPN/NRPN LSB	0102	R/W		7	01	00-00-7F	0 - 127
Data Entry MSB/LSB	0103	R/W		1	01	00-00-01	0...Data MSB 1...Data LSB

23 Tone Parameter

These parameters configure tone settings.

23.1 DSP Parameter

These parameters configure tone DSP settings.

Parameter	ID	R/W	Block	Size	Array	Min-Def-Max	Description
Algorithm	004E	R/W	55-0:0	14	01	0000-0000-3FFF	Algorithm Type
Parameter	004F	R/W		7	20	00-40-7F	0 - 127

23.2 LFO Parameter

These parameters configure tone LFO settings

Parameter	ID	R/W	Block	Size	Array	Min-Def-Max	Description
Vib Wave	0034	R/W	55-0:0	4	01	00-0F-0F	0...Sin

Parameter	ID	R/W	Block	Size	Array	Min-Def-Max	Description
							1...Tri
							2...Saw Up
							3...Saw Down
							4...Pulse 1:3
							5...Pulse 2:2
							6...Pulse 3:1
							15...Depends on original
Vib Rate	0035	R/W		7	01	00-40-7F	-64 - 0 - +63
Vib Auto Delay	0036	R/W		7	01	00-40-7F	-64 - 0 - +63
Vib Auto Rise	0037	R/W		7	01	00-40-7F	-64 - 0 - +63
Vib Auto Depth	0038	R/W		7	01	00-40-7F	-64 - 0 - +63
Vib Mod Depth	0039	R/W		7	01	00-48-7F	-64 - 0 - +63
Vib After Depth	003A	R/W		7	01	00-48-7F	-64 - 0 - +63
Fil Amp Lfo Wave	003B	R/W		4	01	00-0F-0F	0...Sin
							1...Tri
							2...Saw Up
							3...Saw Down
							4...Pulse 1:3
							5...Pulse 2:2
							6...Pulse 3:1
							15...Depends on original
Lfo Rate	003C	R/W		7	01	00-40-7F	-64 - 0 - +63
Lfo Fil Auto Delay	003D	R/W		7	01	00-40-7F	-64 - 0 - +63
Lfo Fil Auto Rise	003E	R/W		7	01	00-40-7F	-64 - 0 - +63
Lfo Fil Auto Depth	003F	R/W		7	01	00-40-7F	-64 - 0 - +63
Lfo Fil Mod Depth	0040	R/W		7	01	00-40-7F	-64 - 0 - +63
Lfo Fil After Depth	0041	R/W		7	01	00-40-7F	-64 - 0 - +63
Lfo Amp Auto Delay	0042	R/W		7	01	00-40-7F	-64 - 0 - +63
Lfo Amp Auto Rise	0043	R/W		7	01	00-40-7F	-64 - 0 - +63
Lfo Amp Auto Depth	0044	R/W		7	01	00-40-7F	-64 - 0 - +63
Lfo Amp Mod Depth	0045	R/W		7	01	00-40-7F	-64 - 0 - +63
Lfo Amp After Depth	0046	R/W		7	01	00-40-7F	-64 - 0 - +63

23.3 Pan Parameter

These parameters configure tone pan settings.

Parameter	ID	R/W	Block	Size	Array	Min-Def-Max	Description
Dynamic Panning	004B	R/W	55-0:0	1	01	00-00-01	0...Off
							1...On
Pan Position	004C	R/W		1	01	00-01-01	0...Pre
							1...Post

23.4 Portamento Parameter

These are tone portamento operation setting parameters.

Parameter	ID	R/W	Block	Size	Array	Min-Def-Max	Description
Portamento Time	005D	R/W	55-0:0	7	01	00-00-7F	0 - 127
Portamento OnOff	005E	R/W		1	01	00-00-01	0...Off
							1...On

23.5 ToneBlock Parameter

23.5.1 Basic Parameter

These parameters configure basic tone settings.

Parameter	ID	R/W	Block	Size	Array	Min-Def-Max	Description
Name	0000	R/W	55-0:0	7	10	00-20-7F	Ascii Character
KeyOff Velocity Mode	0026	R/W		2	01	00-00-02	0...Key Off Velocity

Parameter	ID	R/W	Block	Size	Array	Min-Def-Max	Description
							1...Stored Key On Velocity
							2...Both
Oct Shift	0027	R/W		3	01	02-04-06	-2 - 0 - +2
Level	0029	R/W		7	01	00-64-7F	0 - 127
Chorus Send	0031	R/W		7	01	00-00-7F	0 - 127
Reverb Send	0032	R/W		7	01	00-28-7F	0 - 127
Delete Send	0033	R/W		7	01	00-00-7F	0 - 127
Stretch Tuning	0049	R/W		4	01	00-00-0F	0...Off
							1...Piano1
							2...Piano2
							3...Piano3
							4...Piano4
							5...Piano5
							6...E.Piano1
							7...E.Piano2

23.6 Tone Production Parameter

These parameters configure tone production settings.

Parameter	ID	R/W	Block	Size	Array	Min-Def-Max	Description
Filter Velocity Sense	0004	R/W	55-0:0	7	01	00-7F-7F	-64 - 0 - +63
Amp Velocity Sense	0005	R/W		7	01	00-7F-7F	-64 - 0 - +63
Pitch Env Level Offset	0006	R/W	1-0:Step #	8	01	00-80-FF	-128 - 0 - +127
Pitch Env Rate Offset	0007	R/W		10	01	0000-0200-03FF	-512 - 0 - +511
Cutoff Offset	000C	R/W	55-0:0	8	01	00-80-FF	-128 - 0 - +127
Resonance Offset	000D	R/W		8	01	00-80-FF	-128 - 0 - +127
Filter Env Depth	000E	R/W		7	01	00-7F-7F	0 - 127
Filter Env Level Offset	000F	R/W	2-0:Step #	8	01	00-80-FF	-128 - 0 - +127
Filter Env Rate Offset	0010	R/W		10	01	0000-0200-03FF	-512 - 0 - +511
Amp Env Level Offset	0011	R/W	2-0:Step #	8	01	00-80-FF	-128 - 0 - +127
Amp Env Rate Offset	0012	R/W		10	01	0000-0200-03FF	-512 - 0 - +511

24 Drum Parameter

These parameters configure drum tone settings.

24.1 Instrument Parameter (x128instrument)

These parameters configure settings for each drum tone instrument.

24.1.1 Basic Parameter

These parameters configure basic settings for each drum tone instrument.

Parameter	ID	R/W	Block	Size	Array	Min-Def-Max	Description
Assign Group	0000	R/W	6-0:Key #	7	01	00-00-7F	0 - 15 (0: Off)
Note Off Mode	0002	R/W		1	01	00-00-01	0...Off
							1...On
Instrument Select	000D	R/W		14	01	0000-0000-3FFF	0 - 290

24.1.2 Pitch Parameter

These parameters configure pitch settings for each drum tone instrument.

Parameter	ID	R/W	Block	Size	Array	Min-Def-Max	Description
Coarse & Fine Tune	0003	R/W	6-0:Key #	16	01	0000-0000-FFFF	S-----.- ----- S:sign bit -sssss.- ----- s:semitone (semitone)

Parameter	ID	R/W	Block	Size	Array	Min-Def-Max	Description
							-----c ccccccc c:cent = 100/512 cent resolution 0000000.0 00000000...original 0001100.0 00000000...For +1 octave 1110100.0 00000000...For -1 octave 0000001.0 00000000...For +100 cent(1 semitone) 1111111.0 00000000...For -100 cent(1 semitone) 0000000.1 00000000...For +50 cent 1111111.1 00000000...For -50 cent
Drum Inst Env Level Offset	000E	R/W	6-0:Key # 15-14:Step #	8	01	00-80-FF	-128 - 0 - +127
Drum Inst Env Rate Offset	000F	R/W		10	01	0000-0200-03FF	-512 - 0 - +511

24.1.3 Filter Parameter

These parameters configure filter settings for each drum tone instrument.

Parameter	ID	R/W	Block	Size	Array	Min-Def-Max	Description
Cutoff	0004	R/W	6-0:Key #	8	01	00-80-FF	-128 - 0 - +127
Resonance	0005	R/W		8	01	00-80-FF	-128 - 0 - +127
Envelope Depth	0006	R/W		7	01	00-7F-7F	0 - 127
Init Level	0010	R/W		8	01	00-80-FF	-128 - 0 - +127
Attack Time	0011	R/W		8	01	00-80-FF	-128 - 0 - +127
Attack Level	0012	R/W		8	01	00-80-FF	-128 - 0 - +127
Decay Time	0013	R/W		8	01	00-80-FF	-128 - 0 - +127
Decay Level	0014	R/W		8	01	00-80-FF	-128 - 0 - +127

24.1.4 Amp Parameter

These parameters configure amp settings for each drum tone instrument.

Parameter	ID	R/W	Block	Size	Array	Min-Def-Max	Description
Volume	0007	R/W	6-0:Key #	8	01	00-80-FF	0 - 255
Pan	0008	R/W		7	01	00-40-7F	-64 - 0 - +63
Init Level	0015	R/W		8	01	00-80-FF	-128 - 0 - +127
Attack Time	0016	R/W		8	01	00-80-FF	-128 - 0 - +127
Attack Level	0017	R/W		8	01	00-80-FF	-128 - 0 - +127
Decay Time	0018	R/W		8	01	00-80-FF	-128 - 0 - +127
Decay Level	0019	R/W		8	01	00-80-FF	-128 - 0 - +127

24.1.5 Effect Parameter

These parameters configure effect settings for each drum tone instrument.

Parameter	ID	R/W	Block	Size	Array	Min-Def-Max	Description
Chorus Send	0009	R/W	6-0:Key #	7	01	00-00-7F	0 - 127
Reverb Send	000A	R/W		7	01	00-28-7F	0 - 127
Delay Send	000B	R/W		7	01	00-00-7F	0 - 127
DSP	000C	R/W		1	01	00-01-01	0...0ff 1...0n

25 Hex Layer Parameter

These parameters configure hex layer tone settings.

25.1 Hex Layer Parameter

These parameters configure basic hex layer tone settings.

Parameter	ID	R/W	Block	Size	Array	Min-Def-Max	Description
Volume	002B	R/W	55-0:0	7	01	00-64-7F	0 - 127
Detune Number	002C	R/W		5	01	00-00-1F	0 - 31
Pitch Lock	002D	R/W		1	03	00-00-01	0...Unlocked 1...Locked

25.2 Hex Layer LFO Parameter

These parameters configure hex layer tone LFO settings.

Parameter	ID	R/W	Block	Size	Array	Min-Def-Max	Description
Vib Wave	002E	R/W	55-0:0	4	01	00-00-0F	0...Sin 1...Tri 2...Saw Up 3...Saw Down 4...Pulse 1:3 5...Pulse 2:2 6...Pulse 3:1
Vib Rate	002F	R/W		7	01	00-40-7F	0 - 127
Vib Auto Delay	0030	R/W		7	01	00-00-7F	0 - 127
Vib Auto Rise	0031	R/W		7	01	00-00-7F	0 - 127
Vib Auto Depth	0032	R/W		8	01	00-80-FF	-128 - 0 - +127
Vib Mod Depth	0033	R/W		7	01	00-48-7F	-64 - 0 - +63
Vib After Depth	0034	R/W		7	01	00-48-7F	-64 - 0 - +63
Fil Amp Lfo Wave	0035	R/W		4	01	00-00-0F	0...Sin 1...Tri 2...Saw Up 3...Saw Down 4...Pulse 1:3 5...Pulse 2:2 6...Pulse 3:1
Lfo Rate	0036	R/W		7	01	00-40-7F	0 - 127
Lfo Fil Auto Delay	0037	R/W		7	01	00-00-7F	0 - 127
Lfo Fil Auto Rise	0038	R/W		7	01	00-00-7F	0 - 127
Lfo Fil Auto Depth	0039	R/W		8	01	00-80-FF	-128 - 0 - +127
Lfo Fil Mod Depth	003A	R/W		7	01	00-40-7F	-64 - 0 - +63
Lfo Fil After Depth	003B	R/W		7	01	00-40-7F	-64 - 0 - +63
Lfo Amp Auto Delay	003C	R/W		7	01	00-00-7F	0 - 127
Lfo Amp Auto Rise	003D	R/W		7	01	00-00-7F	0 - 127
Lfo Amp Auto Depth	003E	R/W		8	01	00-80-FF	-128 - 0 - +127
Lfo Amp Mod Depth	003F	R/W		7	01	00-40-7F	-64 - 0 - +63
Lfo Amp After Depth	0040	R/W		7	01	00-40-7F	-64 - 0 - +63

25.3 Hex Layer Tone Edit Parameter (x6layer)

These are hex layer tone editing parameters.

25.3.1 Basic Parameter

These are hex layer tone editing basic parameters.

Parameter	ID	R/W	Block	Size	Array	Min-Def-Max	Description
Layer OnOff	0000	R/W	2-0:Layer #	1	01	00-01-01	0...Off 1...On
Wave Number	0002	R/W		16	01	0000-0000-FFFF	0 - 439
Start Trigger	0003	R/W		1	01	00-00-01	0...Key On 1...Key Off
Key Range Low	0004	R/W		7	01	00-00-7F	0 - 127

Parameter	ID	R/W	Block	Size	Array	Min-Def-Max	Description
Key Range High	0005	R/W		7	01	00-7F-7F	0 - 127
Velocity Range Low	0006	R/W		7	01	00-00-7F	0 - 127
Velocity Range High	0007	R/W		7	01	00-7F-7F	0 - 127

25.3.2 Pitch Parameter

These are hex layer tone editing pitch parameters.

Parameter	ID	R/W	Block	Size	Array	Min-Def-Max	Description
Coarse Tune	000F	R/W	2-0:Layer #	7	01	00-40-7F	Added to key number as 0x40 center.
Fine Tune	0010	R/W		16	01	0000-0000-FFFF	S-----.- ----- S:sign bit -----c cccccccc c:cent = 100/512cent resolution 0000000.1 00000000...For +50 cent 1111111.1 00000000...For -50 cent
Octave Shift	0011	R/W		3	01	02-04-06	-2 - 0 - +2
Key Follow	0012	R/W		8	01	00-C0-FF	-128 - 0 - +127
Key Follow Base	0013	R/W		7	01	00-3C-7F	C- - G9
Envelope Level	0014	R/W	2-0:Layer # 15-14:Step #	15	01	0000-0100-01FF	-256 - 0 - +255
Envelope Time	0015	R/W		7	01	0000-0000-007F	0 - 127
Split Shift	0016	R/W	2-0:Layer #	5	01	00-0C-18	-12 - 0 - +12

25.3.3 Filter Parameter

These are hex layer tone editing filter parameters.

Parameter	ID	R/W	Block	Size	Array	Min-Def-Max	Description
Type	0017	R/W	2-0:Layer #	3	01	00-00-04	0...LPF3 1...HPF 2...BPF 3...LPF1 4...LPF2
Cutoff	0018	R/W		7	01	00-7F-7F	0 - 127
Resonance	0019	R/W		7	01	00-00-7F	0 - 127
Velocity Sense	001A	R/W		7	01	00-7F-7F	0 - 127
Low Key Follow	001B	R/W		8	01	00-80-FF	-128 - 0 - +127
Low Key Follow Base	001C	R/W		7	01	00-3C-7F	C- - G9
Envelope Depth	001D	R/W		7	01	00-7F-7F	0 - 127
Envelope Level	001E	R/W	2-0:Layer # 16-14:Step #	7	01	00-00-7F	0 - 127
Envelope Time	001F	R/W		7	01	00-00-7F	0 - 127
High Key Follow	0027	R/W	2-0:Layer #	8	01	00-80-FF	-128 - 0 -127
High Key Follow Base	0028	R/W		7	01	00-3C-7F	C- - G9

25.3.4 Amp Parameter

These are hex layer tone editing amp parameters.

Parameter	ID	R/W	Block	Size	Array	Min-Def-Max	Description
Volume	0020	R/W	2-0:Layer #	7	01	00-64-7F	0 - 127
Pan	0021	R/W		7	01	00-40-7F	-64 - 0 - +63
Velocity Sense	0022	R/W		7	01	00-7F-7F	0 - 127
Low Key Follow	0023	R/W		8	01	00-80-FF	-128 - 0 - +127
Low Key Follow Base	0024	R/W		7	01	00-3C-7F	C- - G9
Envelope Level	0025	R/W	2-0:Layer # 16-14:Step #	7	01	00-00-7F	0 - 127
Envelope Time	0026	R/W		7	01	00-00-7F	0 - 127
High Key Follow	0029	R/W	2-0:Layer #	8	01	00-80-FF	-128 - 0 -127
High Key Follow Base	002A	R/W		7	01	00-3C-7F	C- - G9

25.3.5 Effect Parameter

These are hex layer tone editing effect parameters.

Parameter	ID	R/W	Block	Size	Array	Min-Def-Max	Description
DSP	0008	R/W	2-0:Layer #	1	01	00-01-01	0...Off 1...On
Reverb Send	0009	R/W		7	01	00-7F-7F	0 - 127
Chorus Send	000A	R/W		7	01	00-7F-7F	0 - 127
Delay Send	000B	R/W		7	01	00-7F-7F	0 - 127

26 Arpeggio Parameter

26.1 Arpeggio Directory Info

The Arpeggio parameter stores Arpeggio data directory information.

Parameter	ID	R/W	Block	Size	Array	Min-Def-Max	Description
Name	0000	R	55-0:0	7	10	20-20-7F	Ascii Character
Size	0002	R		32	01	00000000-00000000-00FFFFFF	0 - 0xFFFFFF

27 Phrase Parameter

27.1 Phrase Directory Info

The Phrase parameter stores Phrase data directory information.

Parameter	ID	R/W	Block	Size	Array	Min-Def-Max	Description
Name	0000	R	55-0:0	7	10	20-20-7F	Ascii Character
Size	0002	R		32	01	00000000-00000000-00FFFFFF	0 - 0xFFFFFF

28 Song Parameter

28.1 Song Directory Info

The Song parameter stores Song data directory information.

Parameter	ID	R/W	Block	Size	Array	Min-Def-Max	Description
Name	0000	R	55-0:0	7	10	20-20-7F	Ascii Character
Size	0002	R		32	01	00000000-00000000-00FFFFFF	0 - 0xFFFFFF

29 Spec Parameter

These are system setting parameters.

Parameter	ID	R/W	Block	Size	Array	Min-Def-Max	Description
Stage Setting Number	0000	R/W	55-0:0	8	01	00-00-63	0 - 99
Stage Setting Filter	0001	R/W		16	01	0000-0020-FFFF	bit0...Tempo bit1...Arpeggio bit2...System Reverb bit3...System Chorus bit4...System Delay bit5...Master Comp bit6...Master EQ bit7...Pedal1 bit8...Pedal2

Parameter	ID	R/W	Block	Size	Array	Min-Def-Max	Description
Master Fine Tune	0003	R/W		10	01	010B-0200-0303	bit9...Phrase bit10...Hammer Response -245 - 0 - +259 (415.5Hz - 440.0Hz - 465.9Hz)
Master Coarse Tune	0004	R/W		7	01	28-40-58	-24 - 0 - +24(semitone)
Panel Transpose	0009	R/W		7	01	34-40-4C	-12 - 0 - +12
Panel Octave Shift	000A	R/W		7	01	3D-40-43	-3 - 0 - +3
External Volume	000B	R/W		7	01	00-64-7F	0 - 127
Local Control	000D	R/W		1	01	00-01-01	0...Off 1...On
LCD Contrast	0010	R/W		7	01	01-09-11	1 - 17
AP0 Mode	0012	R/W		1	01	00-01-01	0...Off 1...On
MIDI Out Select	002B	R/W		4	01	00-00-02	0...Keyboard 1...MIDI IN(MIDI Thru) 2...USB
USB Out Select	002C	R/W		4	01	00-00-01	0...Keyboard 1...MIDI IN(MIDI Thru)
MIDI In	002D	R/W		1	01	00-01-01	0...Off 1...On
USB In	002E	R/W		1	01	00-01-01	0...Off 1...On
Sync Mode	002F	R/W		4	01	00-00-02	0...Off 1...Master 2...Slave
Stage Setting NRPN	0030	R/W		1	01	00-00-01	0...Off 1...On
Device ID	0034	R/W		7	01	00-7F-7F	0 - 127 (127: All)
Basic Ch	0035	R/W		7	01	00-00-0F	0 - 15
Init By Wave	003A	R/W		1	01	00-01-01	0...Off 1...On
Midi Rx Flag	0048	R/W		8	01	00-00-FF	bit0...Control Change bit1...Program Change bit2...Channel Pressure bit3...Pitch Bend
Audio Volume	0049	R/W		7	01	00-7F-7F	0 - 127
Sysfx Bypass OnOff	004A	R/W		1	01	00-00-01	0...Off 1...On
Masfx Bypass OnOff	004B	R/W		1	01	00-00-01	0...Off 1...On
Touch Curve	0040	R/W		2	01	00-02-03	0...Off 1...Light 2...Normal 3...Heavy
Touch Off Velocity	0041	R/W		7	01	01-64-7F	0 - 127
High Reso Velocity Enable	0042	R/W		1	01	00-01-01	0...Off 1...On
Temper Type	0043	R/W		5	01	00-00-10	0 - 16
Base Note	0044	R/W		4	01	00-00-0B	C - B
Phrase Guide	0045	R/W		1	01	00-01-01	0...Off 1...On
Phrase Precount	0046	R/W		2	01	00-00-02	0...Off 1...1 Measure 2...2 Measure
High Reso Rec	0047	R/W		1	01	00-00-01	0...Off 1...On

Part VI

Parameter Set List

This section explains actually how parameter sets can be transferred by the Instrument with bulk dump.

30 Parameter Set Table

Field Contents

- *cat* field
Shows the category value.(Note1)
- *mem* field
Shows the memory area ID value.(Note1)
- *pset* field
Shows the parameter set number value. Applicable parameter set numbers are those in the user area where the top number is zero, and are not the same numbers as those displayed by the Instrument.
(Note1)

Note1: Operation is not guaranteed for values other than those noted here.

Parameter Set Category	<i>cat</i>	<i>mem</i>	<i>pset</i>	description
Stage Setting	02H	01H	0000H - 0063H	(User Stage Setting 0 - 99)
Tone	03H	01H	0000H - 0013H 0014H - 0045H 0046H - 0059H 005AH - 006DH 006EH - 0081H 0082H - 00B3H 00B4H - 00C7H 00C8H - 015DH	(Piano 20 - 39) (Elec Piano 60 - 109) (Organ 30 - 49) (String/Brass 70 - 89) (Guitar/Bass 40 - 59) (Synth/Various 80 - 129) (Drums 20 - 39) (Hex Layer 50 - 199)
Drum	06H	01H	0000H - 0013H	(Drum 20 - 39)
Hex Layer	09H	01H	0000H - 0095H	(Hex Layer 50 - 199)
ArpeggioDir	22H	01H	0000H - 0063H	(Arpeggio 100 - 199)
PhraseDir	23H	01H	0000H - 03E7H	(Phrase 0 - 999)
SongDir	24H	01H	0000H - 0009H	(Song 0 - 9)

Part VII

DSP Parameter List

31 DSP Type List

This is a list of DSP types built into the Instrument.

DSP Number	DSP ID	Type
01	01H	Equalizer
02	02H	Compressor
03	03H	Limiter
04	04H	Enhancer
05	05H	Early Reflection
06	06H	Phaser
07	07H	Chorus
08	08H	Flanger
09	09H	Tremolo
10	0AH	Auto Pan
11	0BH	Rotary
12	0CH	Drive Rotary
13	0DH	LFO Wah
14	0EH	Auto Wah
15	0FH	Distortion
16	10H	Pitch Shifter
17	11H	Multi Chorus
18	12H	Ring Modulator
19	13H	Delay
20	14H	Piano Effect

32 DSP Parameter Set Type

DSP parameters can be changed by General Use Controllers 1 through 8, and NRPN. For details, see "7.8 General Use Controller 1 through 8" and "7.25 NRPN".

32.1 Equalizer

Parameter Number	Parameter Name	Notes
Parameter[1]	EQ1 Frequency	Note1
Parameter[2]	EQ1 Gain	Note2
Parameter[3]	EQ2 Frequency	Note1
Parameter[4]	EQ2 Gain	Note2
Parameter[4]	EQ3 Frequency	Note1
Parameter[5]	EQ3 Gain	Note2
Parameter[7]	Input Level	
Parameter[8]	Wet Level	
Parameter[9]	Dry Level	

Note1: For information about the relationship between setting values and send/receive values, see “33.9 EQ Frequency Setting Value Table” in “VIII Setting Values and Send/Receive Values” of this document.

Note2: For information about the relationship between setting values and send/receive values, see “33.10 EQ Gain Setting Value Table” in “VIII Setting Values and Send/Receive Values” of this document.

32.2 Compressor

Parameter Number	Parameter Name	Notes
Parameter[1]	Attack	
Parameter[2]	Release	
Parameter[3]	Depth	
Parameter[4]	Wet Level	
Parameter[5]	Dry Level	

32.3 Limiter

Parameter Number	Parameter Name	Notes
Parameter[1]	Limit	
Parameter[2]	Attack	
Parameter[3]	Release	
Parameter[4]	Wet Level	
Parameter[5]	Dry Level	

32.4 Enhancer

Parameter Number	Parameter Name	Notes
Parameter[1]	Low Frequency	
Parameter[2]	Low Gain	
Parameter[3]	High Frequency	
Parameter[4]	High Gain	
Parameter[5]	Input Level	
Parameter[6]	Wet Level	
Parameter[7]	Dry Level	

32.5 Early Reflection

Parameter Number	Parameter Name	Notes
Parameter[1]	Wet Level	
Parameter[2]	Feedback	
Parameter[3]	Tone	
Parameter[4]	Input Level	
Parameter[5]	Dry Level	

32.6 Phaser

Parameter Number	Parameter Name	Notes
Parameter[1]	Resonance	
Parameter[2]	Manual	Note1
Parameter[3]	LFO Rate	
Parameter[4]	LFO Depth	
Parameter[5]	LFO Waveform	Note2
Parameter[6]	Input Level	
Parameter[7]	Wet Level	
Parameter[8]	Dry Level	

Note1: For information about the relationship between setting values and send/receive values, see “33.4 -64 - 0 - +63 Setting Value Table” in “VIII Setting Values and Send/Receive Values” of this document.

Note2: For information about the relationship between setting values and send/receive values, see “33.11 LFO Wave Form1 Setting Value Table” in “VIII Setting Values and Send/Receive Values” of this document.

32.7 Chorus

Parameter Number	Parameter Name	Notes
Parameter[1]	LFO Rate	
Parameter[2]	LFO Depth	
Parameter[3]	LFO Waveform	Note1
Parameter[4]	Feedback	Note2
Parameter[5]	Wet Level	
Parameter[6]	Polarity	Note3
Parameter[7]	Input Level	
Parameter[8]	Dry Level	

Note1: For information about the relationship between setting values and send/receive values, see “33.12 LFO Wave Form2 Setting Value Table” in “VIII Setting Values and Send/Receive Values” of this document.

Note2: For information about the relationship between setting values and send/receive values, see “33.4 -64 - 0 - +63 Setting Value Table” in “VIII Setting Values and Send/Receive Values” of this document.

Note3: For information about the relationship between setting values and send/receive values, see “33.14 Polarity Setting Value Table” in “VIII Setting Values and Send/Receive Values” of this document.

32.8 Flanger

Parameter Number	Parameter Name	Notes
Parameter[1]	LFO Rate	
Parameter[2]	LFO Depth	
Parameter[3]	LFO Waveform	Note1
Parameter[4]	Feedback	Note2
Parameter[5]	Wet Level	
Parameter[6]	Input Level	
Parameter[7]	Dry Level	

Note1: For information about the relationship between setting values and send/receive values, see “33.11 LFO Wave Form1 Setting Value Table” in “VIII Setting Values and Send/Receive Values” of this document.

Note2: For information about the relationship between setting values and send/receive values, see “33.4 -64 - 0 - +63 Setting Value Table” in “VIII Setting Values and Send/Receive Values” of this document.

32.9 Tremolo

Parameter Number	Parameter Name	Notes
Parameter[1]	LFO Rate	
Parameter[2]	LFO Depth	
Parameter[3]	LFO Waveform	Note1
Parameter[4]	Wet Level	
Parameter[5]	Dry Level	

Note1: For information about the relationship between setting values and send/receive values, see “33.13 LFO Wave Form3 Setting Value Table” in “VIII Setting Values and Send/Receive Values” of this document.

32.10 Auto Pan

Parameter Number	Parameter Name	Notes
Parameter[1]	LFO Rate	
Parameter[2]	LFO Depth	
Parameter[3]	LFO Waveform	Note1
Parameter[4]	Manual	Note2
Parameter[5]	Wet Level	
Parameter[6]	Dry Level	

Note1: For information about the relationship between setting values and send/receive values, see “33.13 LFO Wave Form3 Setting Value Table” in “VIII Setting Values and Send/Receive Values” of this document.

Note2: For information about the relationship between setting values and send/receive values, see “33.5 Pan Setting Value Table” in “VIII Setting Values and Send/Receive Values” of this document.

32.11 Rotary

Parameter Number	Parameter Name	Notes
Parameter[1]	Speed	Note1
Parameter[2]	Brake	Note2
Parameter[3]	Fall Accel	
Parameter[4]	Rise Accel	
Parameter[5]	Slow Rate	
Parameter[6]	Fast Rate	
Parameter[7]	Vibrato/Chorus	Note3
Parameter[8]	Wet Level	
Parameter[9]	Dry Level	

Note1: For information about the relationship between setting values and send/receive values, see “33.15 Slow/Fast Setting Value Table” in “VIII Setting Values and Send/Receive Values” of this document.

Note2: For information about the relationship between setting values and send/receive values, see “33.16 Rotate/Stop Setting Value Table” in “VIII Setting Values and Send/Receive Values” of this document.

Note3: For information about the relationship between setting values and send/receive values, see “33.17 Vibrato/Chorus Setting Value Table” in “VIII Setting Values and Send/Receive Values” of this document.

32.12 Drive Rotary

Parameter Number	Parameter Name	Notes
Parameter[1]	Overdrive Gain	
Parameter[2]	Overdrive Level	
Parameter[3]	Speed	Note1
Parameter[4]	Brake	Note2
Parameter[5]	Fall Accel	
Parameter[6]	Rise Accel	
Parameter[7]	Slow Rate	
Parameter[8]	Fast Rate	
Parameter[9]	Vibrato/Chorus	Note3
Parameter[10]	Wet Level	
Parameter[11]	Dry Level	

Note1: For information about the relationship between setting values and send/receive values, see “33.15 Slow/Fast Setting Value Table” in “VIII Setting Values and Send/Receive Values” of this document.

Note2: For information about the relationship between setting values and send/receive values, see “33.16 Rotate/Stop Setting Value Table” in “VIII Setting Values and Send/Receive Values” of this document.

Note3: For information about the relationship between setting values and send/receive values, see “33.17 Vibrato/Chorus Setting Value Table” in “VIII Setting Values and Send/Receive Values” of this document.

32.13 LFO Wah

Parameter Number	Parameter Name	Notes
Parameter[1]	Input Level	
Parameter[2]	Resonance	
Parameter[3]	Manual	
Parameter[4]	LFO Rate	
Parameter[5]	LFO Depth	
Parameter[6]	LFO Waveform	Note1
Parameter[7]	Wet Level	
Parameter[8]	Dry Level	

Note1: For information about the relationship between setting values and send/receive values, see “33.11 LFO Wave Form1 Setting Value Table” in “VIII Setting Values and Send/Receive Values” of this document.

32.14 Auto Wah

Parameter Number	Parameter Name	Notes
Parameter[1]	Input Level	
Parameter[2]	Resonance	
Parameter[3]	Manual	
Parameter[4]	Depth	Note1
Parameter[5]	Wet Level	
Parameter[6]	Dry Level	

Note1: For information about the relationship between setting values and send/receive values, see “33.4 -64 - 0 - +63 Setting Value Table” in “VIII Setting Values and Send/Receive Values” 33.4 -64 - 0 - +63 Setting Value Table of this document.

32.15 Distortion

Parameter Number	Parameter Name	Notes
Parameter[1]	Dist Gain	
Parameter[2]	Dist Level	
Parameter[3]	Dist Low	
Parameter[4]	Dist High	
Parameter[5]	Wah Depth	Note1
Parameter[6]	Wah Manual	
Parameter[7]	Routing	Note2
Parameter[8]	Amp	Note3
Parameter[9]	Wet Level	
Parameter[10]	Wet Level	

Note1: For information about the relationship between setting values and send/receive values, see “33.4 -64 - 0 - +63 Setting Value Table” in “VIII Setting Values and Send/Receive Values” of this document.

Note2: For information about the relationship between setting values and send/receive values, see “33.18 Routing Setting Value Table” in “VIII Setting Values and Send/Receive Values” of this document.

Note3: For information about the relationship between setting values and send/receive values, see “33.19 Amp Setting Value Table” in “VIII Setting Values and Send/Receive Values” of this document.

32.16 Pitch Shifter

Parameter Number	Parameter Name	Notes
Parameter[1]	Pitch	Note1
Parameter[2]	High Damp	
Parameter[3]	Feedback	
Parameter[4]	Input Level	
Parameter[5]	Wet Level	
Parameter[6]	Dry Level	
Parameter[7]	Fine	Note2

Note1: For information about the relationship between setting values and send/receive values, see “33.20 Pitch Setting Value Table” in “VIII Setting Values and Send/Receive Values” of this document.

Note2: For information about the relationship between setting values and send/receive values, see “33.21 Pitch Shifter Fine Setting Value Table” in “VIII Setting Values and Send/Receive Values” of this document.

32.17 Multi Chorus

Parameter Number	Parameter Name	Notes
Parameter[1]	LFO Rate	
Parameter[2]	LFO Depth	
Parameter[3]	Wet Level	
Parameter[4]	Dry Level	

32.18 Ring Modulator

Parameter Number	Parameter Name	Notes
Parameter[1]	OSC Frequency	
Parameter[2]	LFO Rate	
Parameter[3]	LFO Depth	
Parameter[4]	Tone	
Parameter[5]	Wet Level	
Parameter[6]	Dry Level	

32.19 Delay

Parameter Number	Parameter Name	Notes
Parameter[1]	Delay Time	
Parameter[2]	Delay Ratio L	
Parameter[3]	Delay Ratio R	
Parameter[4]	Delay Level L	
Parameter[5]	Delay Level R	
Parameter[6]	Feedback Type	Note1
Parameter[7]	Feedback	
Parameter[8]	High Damp	
Parameter[9]	Delay Tempo Sync	Note2
Parameter[10]	Input Level	
Parameter[11]	Dry Level	
Parameter[12]	Wet Level	

Note1: For information about the relationship between setting values and send/receive values, see “33.22 Feedback Type Setting Value Table” in “VIII Setting Values and Send/Receive Values” of this document.

Note2: For information about the relationship between setting values and send/receive values, see “33.23 Delay Tempo Sync Setting Value Table” in “VIII Setting Values and Send/Receive Values” of this document.

32.20 Piano Effect

Parameter Number	Parameter Name	Notes
Parameter[1]	Lid Type	Note1
Parameter[2]	Reflection Level	
Parameter[3]	Input Level	
Parameter[4]	Wet Level	
Parameter[5]	Dry Level	

Note1: For information about the relationship between setting values and send/receive values, see “33.24 Lid Type Setting Value Table” in “VIII Setting Values and Send/Receive Values” of this document.

Part VIII

Setting Values and Send/ Receive Values

33 Setting Value Tables

33.1 Off/On Setting Value Table

Transmit Value	Receive Value	Parameter
00H	00H - 3FH	Off
7FH	40H - 7FH	On

33.2 DSP Bypass Setting Value Table

Transmit Value	Receive Value	Parameter
00H	00H - 3FH	Bypass On
7FH	40H - 7FH	Bypass Off

33.3 Sustain Pedal Setting Value Table

Transmit Value	Receive Value	Parameter
-	00H	Off
:	:	(continuous)
-	7FH	Full

33.4 -64 - 0 - +63 Setting Value Table

Transmit Value	Receive Value	Parameter
00H	00H	-64
:	:	:
40H	40H	0
:	:	:
7FH	7FH	+63

33.5 Pan Setting Value Table

Transmit Value	Receive Value	Parameter
00H	00H	Left
:	:	:
40H	40H	Center
:	:	:
7FH	7FH	Right

33.6 Fine Tuning Setting Value Table

Transmit Value	Receive Value	Parameter
(LSB, MSB)		
(43H, 00H)	(00H, 00H) - (5FH, 00H)	415.5 Hz
(65H, 00H)	(60H, 00H) - (7FH, 00H)	415.6 Hz
(07H, 01H)	(00H, 01H) - (1FH, 01H)	415.7 Hz
(29H, 01H)	(20H, 01H) - (3FH, 01H)	415.8 Hz
:	:	:
(40H, 3FH)	(30H, 3FH) - (4FH, 3FH)	439.8 Hz
(60H, 3FH)	(50H, 3FH) - (6FH, 3FH)	439.9 Hz
(00H, 40H)	(70H, 3FH) - (1FH, 40H)	440.0 Hz
(20H, 40H)	(20H, 40H) - (3FH, 40H)	440.1 Hz
(40H, 40H)	(40H, 40H) - (5FH, 40H)	440.2 Hz
:	:	:
(54H, 7EH)	(50H, 7EH) - (6FH, 7EH)	465.6 Hz
(73H, 7EH)	(70H, 7EH) - (0FH, 7FH)	465.7 Hz
(11H, 7FH)	(10H, 7FH) - (2FH, 7FH)	465.8 Hz
(30H, 7FH)	(30H, 7FH) - (7FH, 7FH)	465.9 Hz

33.7 Reverb Type Setting Value Table

Transmit Value	Receive Value	Parameter
-	00H	Room
-	01H	Room
-	02H	Room
-	03H	Hall1
-	04H	Hall2
-	08H	Plate

33.8 Chorus Type Setting Value Table

Transmit Value	Receive Value	Parameter
-	00H	Light Cho
-	01H	Light Cho
-	02H	Chorus
-	03H	Chorus
-	04H	FB Chorus
-	05H	Flanger

33.9 EQ Frequency Setting Value Table

Receive Value	DSP Parameter Value	Parameter
00H - 05H	08H	100Hz
06H - 0BH	09H	125Hz
0CH - 12H	0AH	160Hz
13H - 18H	0BH	200Hz
19H - 1FH	0CH	250Hz
20H - 25H	0DH	315Hz
26H - 2BH	0EH	400Hz
2CH - 32H	0FH	500Hz
33H - 38H	10H	630Hz
39H - 3FH	11H	800Hz
40H - 45H	00H	1.0kHz
46H - 4BH	01H	1.3kHz
4CH - 52H	02H	1.6kHz
53H - 58H	03H	2.0kHz
59H - 5FH	04H	2.5kHz
60H - 65H	05H	3.2kHz
66H - 6BH	06H	4.0kHz
6CH - 72H	07H	5.0kHz
73H - 78H	12H	6.0kHz
79H - 7FH	13H	8.0kHz

33.10 EQ Gain Setting Value Table

Receive Value	DSP Parameter Value	Parameter
00H - 04H	34H	-12
05H - 09H	35H	-11
0AH - 0EH	36H	-10
0FH - 13H	37H	-9
14H - 18H	38H	-8
19H - 1DH	39H	-7
1EH - 22H	3AH	-6
23H - 27H	3BH	-5
28H - 2DH	3CH	-4
2EH - 32H	3DH	-3
33H - 37H	3EH	-2
38H - 3CH	3FH	-1
3DH - 41H	40H	+0
42H - 46H	41H	+1
47H - 4BH	42H	+2
4CH - 50H	43H	+3
51H - 56H	44H	+4
57H - 5BH	45H	+5
5CH - 60H	46H	+6
61H - 65H	47H	+7
66H - 6AH	48H	+8
6BH - 6FH	49H	+9
70H - 74H	4AH	+10
75H - 79H	4BH	+11
7AH - 7FH	4CH	+12

Note: The gain value does not exactly correspond to decibels (dB)

33.11 LFO Wave Form1 Setting Value Table

Receive Value	DSP Parameter Value	Parameter
00H - 29H	00H	Sin
2AH - 54H	01H	Tri
55H - 7FH	02H	Random

33.12 LFO Wave Form2 Setting Value Table

Receive Value	DSP Parameter Value	Parameter
00H - 3FH	00H	Sin
40H - 7FH	01H	Tri

33.13 LFO Wave Form3 Setting Value Table

Receive Value	DSP Parameter Value	Parameter
00H - 29H	00H	Sin
2AH - 54H	01H	Tri
55H - 7FH	02H	Tra

33.14 Polarity Setting Value Table

Receive Value	DSP Parameter Value	Parameter
00H - 3FH	00H	-
40H - 7FH	01H	+

33.15 Slow/Fast Setting Value Table

Receive Value	DSP Parameter Value	Parameter
00H - 3FH	00H	Slow
40H - 7FH	01H	Fast

33.16 Rotate/Stop Setting Value Table

Receive Value	DSP Parameter Value	Parameter
00H - 3FH	00H	Rotate
40H - 7FH	01H	Stop

33.17 Vibrato/Chorus Setting Value Table

Receive Value	DSP Parameter Value	Parameter
00H - 11H	00H	Off
12H - 23H	01H	V1
24H - 35H	02H	C1
36H - 48H	03H	V2
49H - 5AH	04H	C2
5BH - 6CH	05H	V3
6DH - 7FH	06H	C3

33.18 Routing Setting Value Table

Receive Value	DSP Parameter Value	Parameter
00H - 1FH	00H	Dist
20H - 3FH	01H	Wah
40H - 5FH	02H	Wah-Dist
60H - 7FH	03H	Dist-Wah

33.19 Amp Setting Value Table

Receive Value	DSP Parameter Value	Parameter
00H - 0BH	00H	Bypass
0CH - 18H	01H	TCombo
19H - 25H	02H	FCombo
26H - 32H	03H	ACombo
33H - 3FH	04H	Bcombo
40H - 4BH	05H	JCombo
4CH - 58H	06H	MStack
59H - 65H	07H	RStack
66H - 72H	08H	BassC
73H - 7FH	09H	BassS

33.20 Pitch Setting Value Table

Receive Value	DSP Parameter Value	Parameter(quarter tone)
00H - 01H	28H	-24
02H - 04H	29H	-23
05H - 06H	2AH	-22
07H - 09H	2BH	-21
0AH - 0CH	2CH	-20
0DH - 0EH	2DH	-19
0FH - 11H	2EH	-18
12H - 13H	2FH	-17
14H - 16H	30H	-16
17H - 19H	31H	-15
1AH - 1BH	32H	-14
1CH - 1EH	33H	-13
1FH - 20H	34H	-12
21H - 23H	35H	-11
24H - 26H	36H	-10
27H - 28H	37H	-9
29H - 2BH	38H	-8
2CH - 2EH	39H	-7
2FH - 30H	3AH	-6
31H - 33H	3BH	-5
34H - 35H	3CH	-4
36H - 38H	3DH	-3
39H - 3BH	3EH	-2
3CH - 3DH	3FH	-1
3EH - 40H	40H	+0
41H - 42H	41H	+1
43H - 45H	42H	+2
46H - 48H	43H	+3
49H - 4AH	44H	+4
4BH - 4DH	45H	+5
4EH - 4FH	46H	+6
50H - 52H	47H	+7
53H - 55H	48H	+8
56H - 57H	49H	+9
58H - 5AH	4AH	+10
5BH - 5DH	4BH	+11
5EH - 5FH	4CH	+12
60H - 62H	4DH	+13
63H - 64H	4EH	+14
65H - 67H	4FH	+15
68H - 6AH	50H	+16
6BH - 6CH	51H	+17
6DH - 6FH	52H	+18
70H - 71H	53H	+19
72H - 74H	54H	+20
75H - 77H	55H	+21
78H - 79H	56H	+22
7AH - 7CH	57H	+23
7DH - 7FH	58H	+24

33.21 Pitch Shifter Fine Setting Value Table

Receive Value	DSP Parameter Value	Parameter(quarter tone/50)
00H	0EH	-50
01H	0FH	-49
02H	10H	-48
03H - 04H	11H	-47
05H	12H	-46
:	:	:
3CH - 3DH	3EH	-2
3EH	3EH	-1
3FH - 40H	40H	0
41H	41H	1
42H	42H	2
:	:	:
79H	6EH	46
7AH - 7BH	6FH	47
7CH	70H	48
7DH	71H	49
7EH - 7FH	72H	50

33.22 Feedback Type Setting Value Table

Receive Value	DSP Parameter Value	Parameter
00H - 3FH	00H	Stereo
40H - 7FH	01H	Cross

33.23 Delay Tempo Sync Setting Value Table

Receive Value	DSP Parameter Value	Parameter(beat)
00H - 0AH	00H	Off
0BH - 16H	01H	1/4
17H - 21H	02H	1/3
22H - 2DH	03H	3/8
2EH - 39H	04H	1/2
3AH - 44H	05H	2/3
45H - 50H	06H	3/4
51H - 7FH	07H	1

33.24 Lid Type Setting Value Table

Receive Value	DSP Parameter Value	Parameter
00H - 29H	00H	Closed
2AH - 54H	01H	Semi Opened
55H - 7FH	02H	Full Opened

33.25 -128 - 0 - +127 Setting Value Table

Transmit Value	Receive Value	Parameter
(LSB, MSB)		
-	(00H, 00H) - (3FH, 00H)	-128
-	(40H, 00H) - (7FH, 00H)	-127
-	(00H, 01H) - (3FH, 01H)	-126
:	:	:
-	(00H, 40H) - (3FH, 40H)	0
:	:	:
-	(40H, 7EH) - (7FH, 7EH)	+125
-	(00H, 7FH) - (3FH, 7FH)	+126
-	(40H, 7FH) - (7FH, 7FH)	+127

33.26 -256 - 0 - +255 Setting Value Table

Transmit Value	Receive Value	Parameter
(LSB, MSB)		
-	(00H, 00H) - (1FH, 00H)	-256
-	(20H, 00H) - (3FH, 00H)	-255
-	(40H, 00H) - (5FH, 00H)	-254
-	(60H, 00H) - (7FH, 00H)	-253
-	(00H, 01H) - (1FH, 01H)	-252
:	:	:
-	(00H, 40H) - (1FH, 40H)	0
:	:	:
-	(60H, 7EH) - (7FH, 7EH)	+251
-	(00H, 7FH) - (1FH, 7FH)	+252
-	(20H, 7FH) - (3FH, 7FH)	+253
-	(40H, 7FH) - (5FH, 7FH)	+254
-	(60H, 7FH) - (7FH, 7FH)	+255

33.27 Hex Layer Detune Setting Value Table

Transmit Value	Receive Value	Parameter
MSB		
-	00H - 03H	0
-	04H - 07H	1
:	:	:
-	78H - 7BH	30
-	7CH - 7FH	31

33.28 Octave Shift Setting Value Table

Transmit Value	Receive Value	Parameter
MSB		
-	00H - 18H	-2
-	19H - 32H	-1
-	33H - 4BH	-0
-	4CH - 65H	+1
-	66H - 7FH	+2

Part IX

MIDI Implementation Notation

34 Value Notation

34.1 Hexadecimal Notation

MIDI implementation sometimes requires that data be expressed in hexadecimal format. Hexadecimal values are indicated by the letter “H” after the value. The hexadecimal equivalents of decimal values 10 through 15 are expressed as the letters A through F.

The table below shows the hexadecimal equivalents for decimal values 0 through 127, which are often used in MIDI messages.

Decimal	Hexadecimal	Decimal	Hexadecimal	Decimal	Hexadecimal	Decimal	Hexadecimal
0	00H	32	20H	64	40H	96	60H
1	01H	33	21H	65	41H	97	61H
2	02H	34	22H	66	42H	98	62H
3	03H	35	23H	67	43H	99	63H
4	04H	36	24H	68	44H	100	64H
5	05H	37	25H	69	45H	101	65H
6	06H	38	26H	70	46H	102	66H
7	07H	39	27H	71	47H	103	67H
8	08H	40	28H	72	48H	104	68H
9	09H	41	29H	73	49H	105	69H
10	0AH	42	2AH	74	4AH	106	6AH
11	0BH	43	2BH	75	4BH	107	6BH
12	0CH	44	2CH	76	4CH	108	6CH
13	0DH	45	2DH	77	4DH	109	6DH
14	0EH	46	2EH	78	4EH	110	6EH
15	0FH	47	2FH	79	4FH	111	6FH
16	10H	48	30H	80	50H	112	70H
17	11H	49	31H	81	51H	113	71H
18	12H	50	32H	82	52H	114	72H
19	13H	51	33H	83	53H	115	73H
20	14H	52	34H	84	54H	116	74H
21	15H	53	35H	85	55H	117	75H
22	16H	54	36H	86	56H	118	76H
23	17H	55	37H	87	57H	119	77H
24	18H	56	38H	88	58H	120	78H
25	19H	57	39H	89	59H	121	79H
26	1AH	58	3AH	90	5AH	122	7AH
27	1BH	59	3BH	91	5BH	123	7BH
28	1CH	60	3CH	92	5CH	124	7CH
29	1DH	61	3DH	93	5DH	125	7DH
30	1EH	62	3EH	94	5EH	126	7EH
31	1FH	63	3FH	95	5FH	127	7FH

34.2 Binary Notation

When a MIDI implementation data value is expressed in binary, the letter “B” (for “binary”) is affixed at the end of the value. The table below shows the binary equivalents for the decimal values 0 through 127, which are often used for settings.

Decimal	Hexadecimal	Binary
0	00H	00000000B
1	01H	00000001B
2	02H	00000010B
3	03H	00000011B
4	04H	00000100B
5	05H	00000101B
6	06H	00000110B
7	07H	00000111B
8	08H	00001000B
9	09H	00001001B
10	0AH	00001010B
11	0BH	00001011B
12	0CH	00001100B
13	0DH	00001101B
14	0EH	00001110B
15	0FH	00001111B
16	10H	00010000B
:	:	
125	7DH	01111101B
126	7EH	01111110B
127	7FH	01111111B

CASIO®