

TRACKFORMER

EN

XW-PD1

USER'S GUIDE (Tutorial)

- Before using this TRACKFORMER for the first time, be sure to read the separate USER'S GUIDE (Basics) to familiarize yourself with basic operations.

Contents

Names of Controllers and their Functions..... EN-1

Connection Examples.....EN-3

Sequence Creation Flow..... EN-4

1. Getting Ready..... EN-4
2. Creating a Basic Pattern..... EN-4
3. Layering..... EN-5
4. Increasing the Number of Patterns..... EN-5
5. After You're Done..... EN-5

Effect System..... EN-6

Sampling Tutorial..... EN-7

- Assigning the Sampled Sound to all of the Pads..... EN-7
- Assigning a Sampled Tone to a Specific Pad..... EN-7
- Sampling while Holding Down a
Sequence Step Key..... EN-7
- Specifying the Number of Beats and Sampling..... EN-8

Mastering TRACKFORMER Operations..... EN-9

- Navigating Between FUNCTION Modes..... EN-9
- Producing a Particular Sound or Sounds..... EN-9
- Muting a Particular Sound or Sounds..... EN-10
- Deleting Data..... EN-10
- Copying Data..... EN-11
- Changing the Pitch of a Sequence..... EN-12
- Changing the Number of Steps Per Measure..... EN-12
- Applying a Swing Effect..... EN-12
- Entering the MIDI Control Mode..... EN-13
- Changing the Configuration of a Pattern..... EN-13
- Changing the Pad Velocity..... EN-14
- Changing the Pad Set Volume Level..... EN-14
- Changing the Operation of a Pad..... EN-14
- Changing the Initial Default Slice Length..... EN-16
- Using the Equalizer..... EN-16
- Using the Metronome..... EN-16

Configuring Other Settings..... EN-17

- Configuring Settings..... EN-17
- Menu and Setting List..... EN-17

Adjusting Controller Operations..... EN-20

- Calibrating Knob and Fader Alignment..... EN-20
- Adjusting Pad Sensitivity..... EN-21

Connecting to a Computer..... EN-22

- Minimum Computer System Requirements..... EN-22
- Connecting TRACKFORMER
to Your Computer..... EN-22
- Using MIDI..... EN-23
- Saving and Loading TRACKFORMER Data
to a Computer and Editing TRACKFORMER
Data on a Computer..... EN-23

Appendix..... EN-24

- Step Sequence List..... EN-24
- Pad Set Tone List..... EN-25
- Pad Tone List..... EN-28
- Drum Assignment List..... EN-31
- Effect List..... EN-33
- Signal Diagram..... EN-36
- Internal Sound Source Operation Flow..... EN-36

MIDI Implementation Chart

Company and product names used in this manual may be registered trademarks of others.

Names of Controllers and their Functions

- This section explains the numbers and names used in this manual for buttons and controllers.

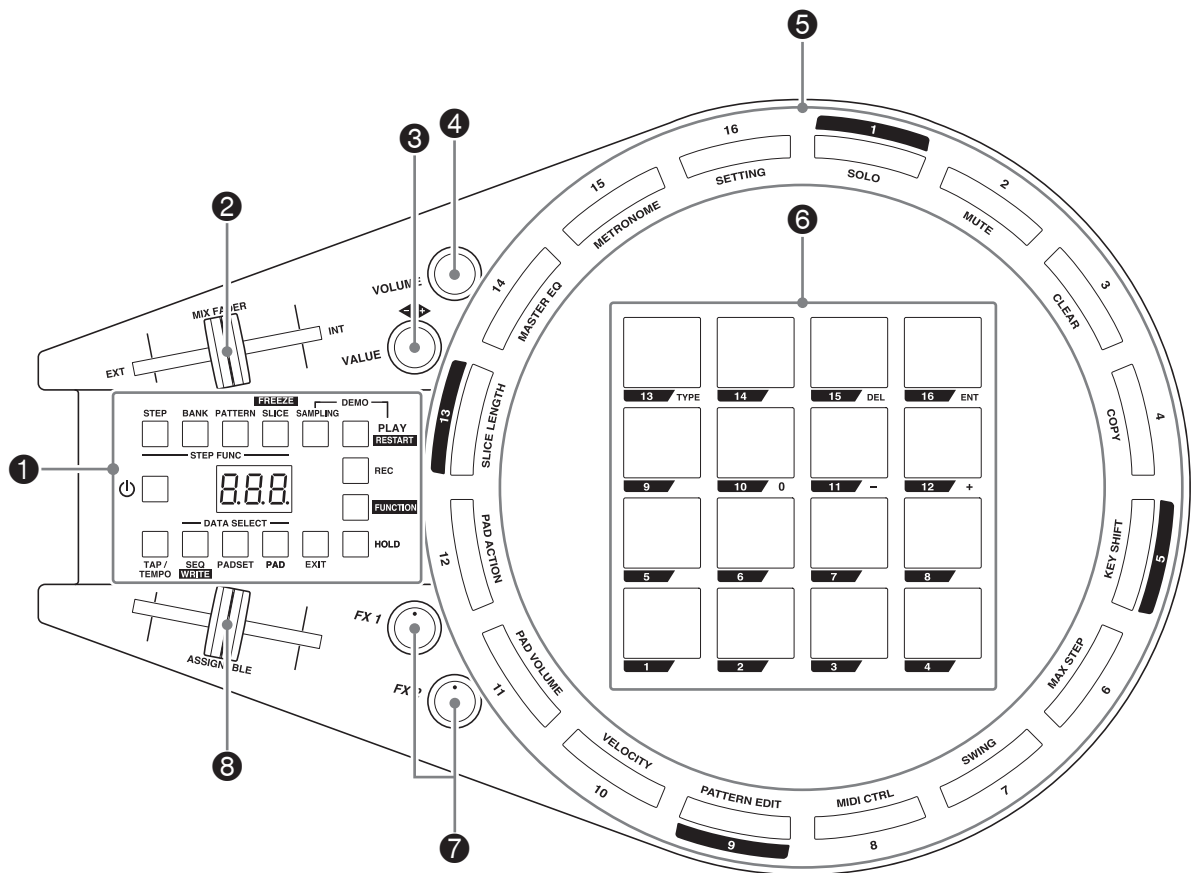

1 Selector panel

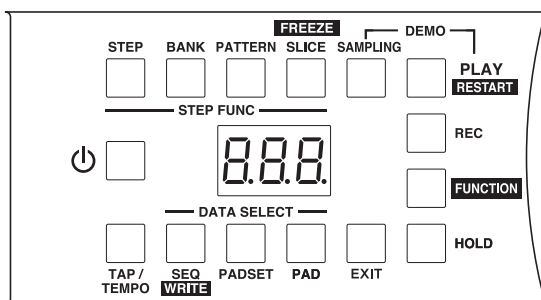

- **1** (Power) button
- Display
- **STEP** button
Enables creation of sequence data using the sequence step keys.
- **BANK** button
Enables bank selection using the sequence step keys.
- **PATTERN** button
Enables pattern selection using the sequence step keys.
- **SLICE** button
Enables slicing of sequence data or an external sound source using the sequence step keys.
- **SAMPLING** button
Samples a sequence or external input.
- **PLAY** button
Starts and stops sequence playback.
- **REC** button
Starts and stops real-time recording. Also used to start and stop sampling.
- **FUNCTION** button
Used for configuring detailed settings.
- **HOLD** button
Puts sounds and/or effects into a hold state.
- **EXIT** button
Backsteps to the previous menu or other screen.
- **PAD** button
Switches a particular pad's tone and/or effect.
- **PADSET** button
Switches the tone and/or effect of all pads.
- **SEQ** button
Switches the sequence.
- **TAP/TEMPO** button
Adjusts playback tempo.

② MIX FADER

Adjusts the volume balance between the internal sound source (sequence) and an external sound source.

③ VALUE knob

Rotate to change a value. Rotating to the left reduces the value, while rotating to the right increase it. The extent that the value is changed depends on how much the knob is rotated. Positioning the knob at 12 o'clock stops the value change operation.

④ VOLUME knob**⑤ Sequence step keys**

When using the step sequencer, toggle each step between on and off. These keys are also used when configuring detailed settings.

⑥ Pads

Tap to produce a sound or apply an effect. You can also use these pads to input or change a number or value setting.

⑦ FX1/FX2 knobs

Adjust the intensity of the applied effects.

⑧ ASSIGNABLE fader

Can be used to apply a scratch effect. The function assigned to this fader can be specified by you.

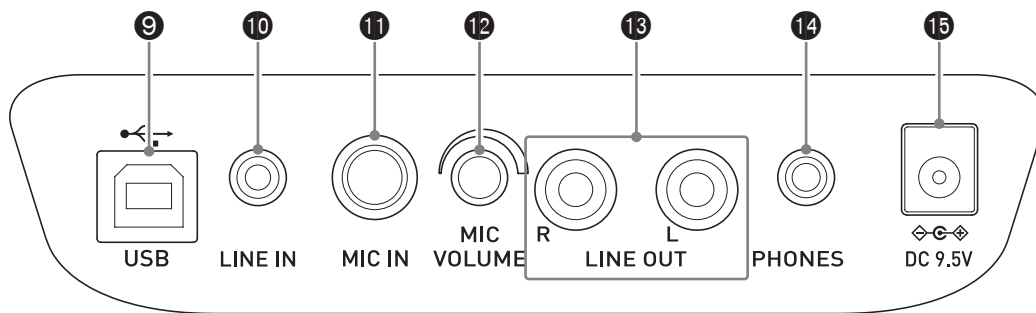
**⑨ USB port**

Use a USB cable to connect to a computer, etc.

⑩ LINE IN terminal

Use to plug in a cable with a stereo mini plug to connect with a portable audio player, etc.

⑪ MIC IN terminal

Use to plug in a microphone with a monaural standard plug.

⑫ MIC VOLUME knob

Adjusts the microphone input level.

⑬ LINE OUT L/R terminals

Use to plug in a cable with RCA pin plugs to connect a speaker, mixer, etc.

⑭ PHONES terminals

Use to plug in headphones with a stereo mini plug.

⑮ DC 9.5V terminal

Use to connect the supplied AC adaptor to supply power from a household power outlet.

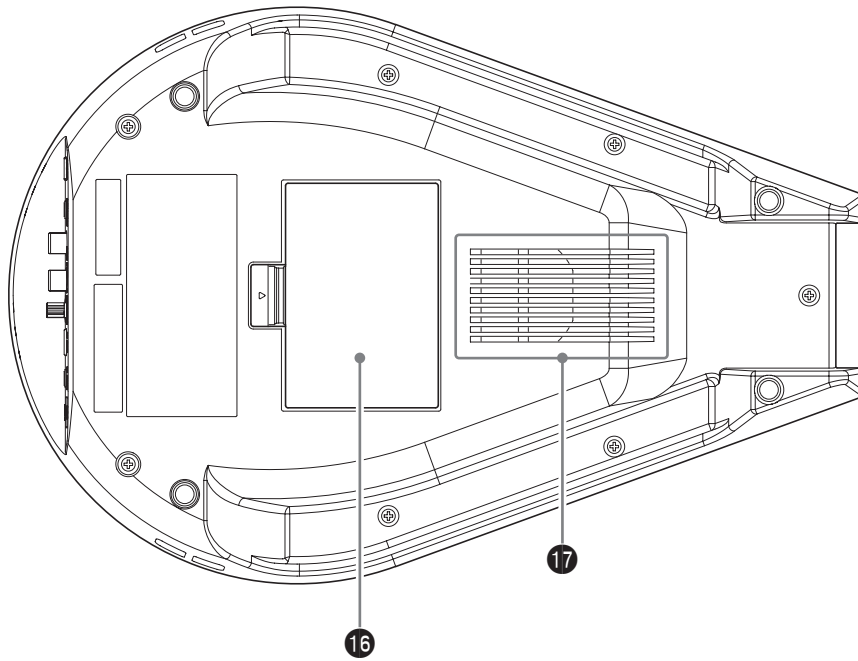

16 Battery compartment

17 Speaker

Connection Examples

IMPORTANT!

- Before connecting an external device, first set **VOLUME** to minimum volume.

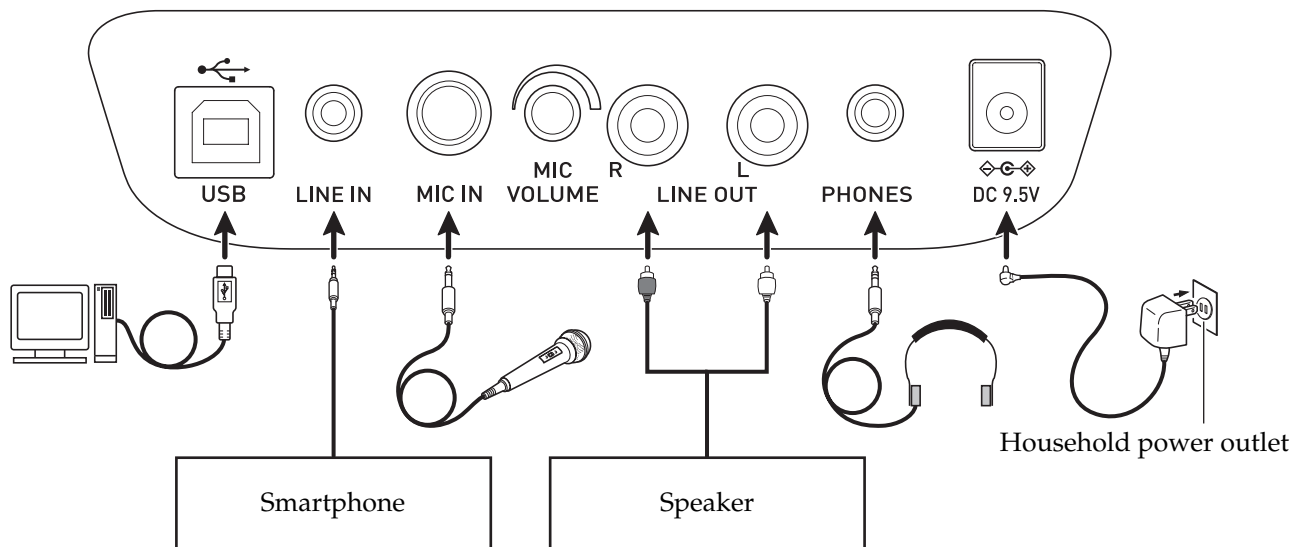

Sequence Creation Flow

This section provides a general overview of sequence creation steps.

1. Getting Ready

Selecting a Sequence Data File Number

While holding down the **SEQ** selector button, use pads **11 (-)** and **12 (+)** to specify a sequence data file number.

- Data file numbers 100 to 149 are rewritable by you. There is no data assigned to these file numbers when TRACKFORMER is shipped from the factory.

To delete data currently assigned to a data file number

1. While holding down the **FUNCTION** selector button, press sequence step key **3 (CLEAR)**.
2. Press the **SEQ** selector button and then press pad **16 (ENT)**.

2. Creating a Basic Pattern

To assign a sound to a step

1. Press the **STEP** selector button and then press the **PLAY** button.
2. Press the pad of the sound you want to assign and then press the sequence step key to assign the sound.
 - If you don't want anything to sound when you press a particular pad, hold down the **STEP** selector button as you press the applicable pad.

NOTE

- For information about how to assign sound to a step as you record it, refer to the "User's Guide (Basics)" that comes with TRACKFORMER.

To assign tones and effects to all pads or to a particular pad

NOTE

- For information about tone types that can be assigned, refer to the "User's Guide (Basics)" that comes with TRACKFORMER.

■ To assign to all pads

1. While holding down the **PADSET** selector button, use pad **13 (TYPE)** to select a tone type.
2. While holding down the **PADSET** selector button, use pads **11 (-)** and **12 (+)** to change the tone.

■ To assign to a particular pad

1. Press the pad whose tone you want to change.
2. While holding down the **PAD** selector button, use pad **13 (TYPE)** to select a tone type.
3. While holding down the **PAD** selector button, use pads **11 (-)** and **12 (+)** to change the tone assigned to the pad you pressed in step 1.

3. Layering

To change the bank

After pressing the **BANK** selector button, press the sequence step key that corresponds to the number of the bank you want to use.

To delete a bank sequence

After pressing the **BANK** selector button, hold down the sequence step key that corresponds to the bank number of the data you want to delete. The display shown below appears to indicate that the sequence recorded in the bank is deleted.



NOTE

- You can also use the **FUNCTION CLEAR** mode to delete the settings of a particular bank. This will not only delete the sequence, it will also initialize the tones and other settings of the pads. For more information, see “To delete bank settings” (page EN-10).

4. Increasing the Number of Patterns

To enable a pattern group

- Press the **PATTERN** selector button.
- Press the sequence step key (**11 to 14**) that corresponds to the pattern group you want to select. A flashing sequence step key indicates that its pattern group is enabled.

Enabled pattern groups are played back in sequence.

- Pressing the sequence step key of an enabled pattern group will disable the group.

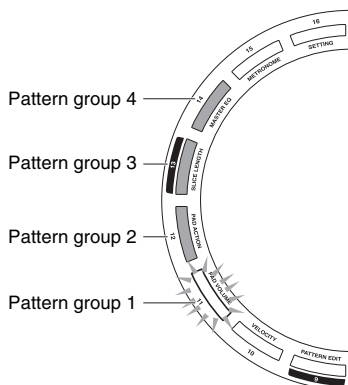

To change the configuration of a pattern using Pattern Edit

For details about configuring a pattern, see “Changing the Configuration of a Pattern” (page EN-13).

5. After You’re Done

To copy or delete a pattern you created

See “To copy pattern contents” (page EN-11) and “To delete a pattern” (page EN-10) for information about these procedures.

To save sequence data

- While holding down the **FUNCTION** selector button, press the **SEQ (WRITE)** button.
- Use pads **11 (-)** and **12 (+)** to specify the number of the sequence data file (100 to 149) where you want to store the sequence.
- Press pad **16 (ENT)**.

Effect System

TRACKFORMER comes with 200 built-in effects. These effects are divided among the four blocks shown in the table below. One effect can be assigned per block, which means you can apply up to four effects simultaneously. For information about which built-in effect belongs to each block see the Effect List (page EN-33).

Block	Effect Type
A	Roll, Reverse Roll, Step Back, Tape Stop, LFO Scratch
B	Filter, Flanger, Tremolo, Gater, Pitch Shifter, Distortion, Crusher, Ring Modulator, Noise Generator
C	Filter, Flanger, Tremolo, Gater, Pitch Shifter, Distortion, Crusher, Ring Modulator, Noise Generator, Panner, Delay
D	Reverb

■ Effect Block Diagram

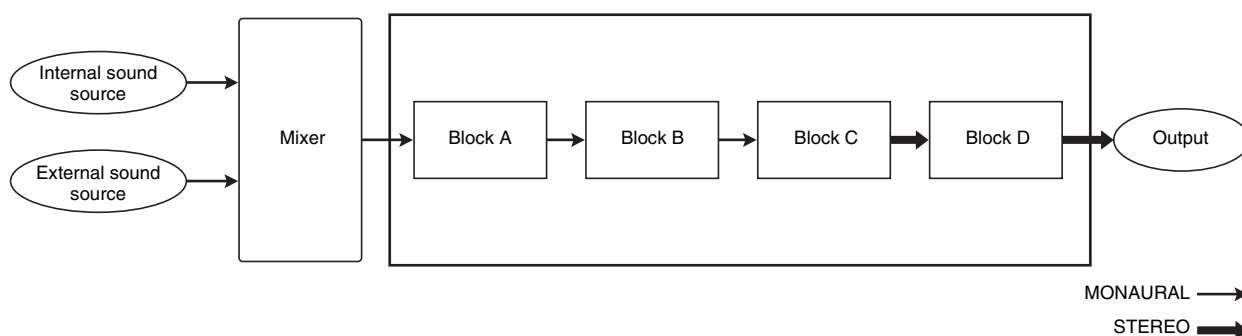

NOTE

- Applying the scratch effect by moving the **ASSIGNABLE** fader while the scratch effect is assigned to it or pressing a pad that has LFO Scratch assigned to it will cancel out all other effects.
- Attempting to apply multiple effects of the same block will result in application of only the final effect.
- Some effects are assigned to two blocks. For example, the PitchUp-Roll effect is assigned to both Block A and Block B, so effects that can be applied along with it are effects assigned to Block C and Block D.
- Except for Panner and Delay, the same effect type is assigned to Block B and Block C. Because of this, if you apply a Block B effect type while another effect is already assigned to Block B, the newly applied effect is assigned to Block C. Conversely, if you apply a Block C effect type while another effect is already assigned to Block C, the newly applied effect is assigned to Block B. For example, the LPF effect can be assigned to Block B only. However, applying LPF while PitchUp-Roll is in use causes an effect type derived from PitchUp-Roll to be assigned to Block A and Block B, and an effect type derived from LPF to be assigned to Block C.
- The same effect type cannot be assigned to Block B and Block C.
- The effect assigned to Block A becomes disabled when slicing.
- When the setting of the effect knob target is "Last," operation of the knob may not change how the effect is applied, even though the effect itself is applied.

Sampling Tutorial

TRACKFORMER lets you sample the built-in sound source or an external sound source and assign the result to a pad. You can also use this function to record samples while slicing. For information about sampling basics, refer to the “User’s Guide (Basics)” that comes with TRACKFORMER.

Assigning the Sampled Sound to all of the Pads

Making all pad tones melody type and then sampling causes the sampled sound to be assigned to all of the pads. In this case, a specified pad is the sound source and all pads are assigned the sampled sound.

1. Make all pad tones melody type.
2. Press the **SAMPLING** selector button.
3. Press the pad you want to use as the sound source.
4. Press the **REC** selector button.
This starts recording.
5. Play the sound you want to sample.
6. Recording will stop when you press the **REC** button again or after the specified recording time elapses.
 - The pad you pressed in step 3 will be the sound source while all pads will be assigned the sampled sound.

NOTE

- For information about how to make all pad tones melody type, refer to the “User’s Guide (Basics)” that comes with TRACKFORMER.

Assigning a Sampled Tone to a Specific Pad

Making all pad tones drum type and then sampling makes it possible to assign the sampled sound to a specific pad.

1. Make all pad tones drum type.
2. Press the **SAMPLING** selector button.
3. Press the pad to which you want to assign the sampled sound.
4. Press the **REC** selector button.
This starts recording.
5. Play the sound you want to sample.
6. Recording will stop when you press the **REC** button again or after the specified recording time elapses.
 - This assigns the sample sound to the pad you pressed in step 3.

NOTE

- For information about how to make all pad tones drum type, refer to the “User’s Guide (Basics)” that comes with TRACKFORMER.

Sampling while Holding Down a Sequence Step Key

1. Press the **SLICE** selector button.
2. While playing back the sound you want to sample, press a sequence step key to slice.
 - Perform the steps below while holding down the sequence step key.
3. Press the **SAMPLING** selector button.
4. Press the pad to which you want to assign the sampled sound.
5. Press the **REC** selector button.
This samples the sliced sound.
6. Recording will stop when you press the **REC** button again or after the specified recording time elapses.

Specifying the Number of Beats and Sampling

You can use the procedure below to specify the number of beats to be sampled in a range of 1 to 16, and then sample a sound. The range of the number of beats you can specify depends on the sample length and the tempo.

1. Enable Sampling Tempo Sync.

- For information about configuring this setting, see “Configuring Settings” under “Configuring Other Settings” (page EN-17), and “Sampling Tempo Sync” under “Menu and Setting List” (page EN-17).

2. Press the **SAMPLING** selector button.

3. Press the pad to which you want to assign the sampled sound.

4. Press the sequence step key that corresponds to the number of beats you want to specify.

- The sequence step keys that correspond to the supported number of beats settings will be lit.
- To cancel a number of beats setting, press the flashing sequence step key so it stops flashing and remains lit.

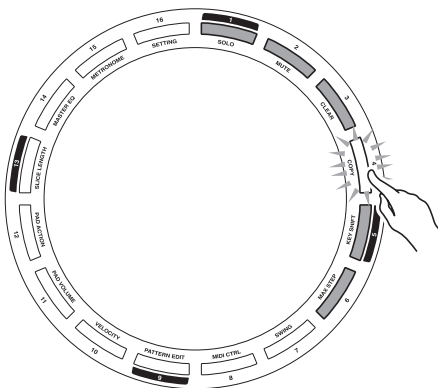

5. Press the **REC** selector button.

This starts recording.

6. Play the sound you want to sample.

7. Recording will stop when you press the **REC** button again or after the specified number of beats is exceeded.

- This assigns the sampled sound to the pad you pressed in step 3.

Mastering TRACKFORMER Operations

The FUNCTION mode lets you change the configuration of a variety of different settings.

Navigating Between FUNCTION Modes

1. While holding down the **FUNCTION** selector button, press the sequence step key that corresponds to the mode you want to use.

- Entering a mode causes the **FUNCTION** button as well as the pads and sequence step keys that are enabled in the mode to light.

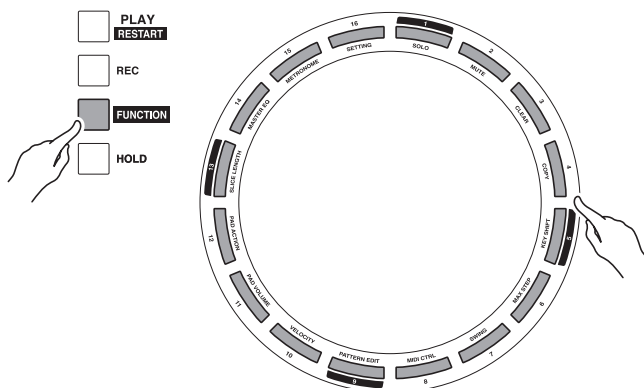

2. To exit a FUNCTION mode, press the **FUNCTION** button again.

To step back to the previous menu level, press the **EXIT** selector button.

FUNCTION Mode List

Sequence Step Key (Mode)	Display Message	Description
1 (SOLO)	SOL	For sounding a particular sound only.
2 (MUTE)	MUTE	For muting a particular sound.
3 (CLEAR)	CLR	For deleting data.
4 (COPY)	CPY	For copying data.
5 (KEY SHIFT)	SFT	For changing the pitch of a sequence.
6 (MAX STEP)	STP	For changing the maximum number of steps in a sequence.
7 (SWING)	SWG	For applying a swing effect.
8 (MIDI CTRL)	CTL	Enters the MIDI control mode.
9 (PATTERN EDIT)	PTE	For changing the configuration of a pattern.

Sequence Step Key (Mode)	Display Message	Description
10 (VELOCITY)	VEL	For changing the pad velocity (degree of volume level change).
11 (PAD VOLUME)	VOL	For changing the pad set volume level.
12 (PAD ACTION)	ACT	For changing the operation of a pad when it is tapped.
13 (SLICE LENGTH)	LEN	For changing the initial default slice length.
14 (MASTER EQ)	EQ	For adjusting the master equalizer.
15 (METRONOME)	ON/OFF	Toggles the metronome between on and off.
16 (SETTING)	SET	For other settings.

Producing a Particular Sound or Sounds

Use the procedure below when you want to produce all of the sounds in a bank or the sound of a particular pad in a bank.

1. Enter the SOLO mode.
2. Press the sequence step key that corresponds to the number of bank whose sounds you want to produce, or press the pad whose sound you want to produce.

This causes the corresponding sound or sounds to be produced.

- The soloing bank (sequence step key) or pad will become lit.

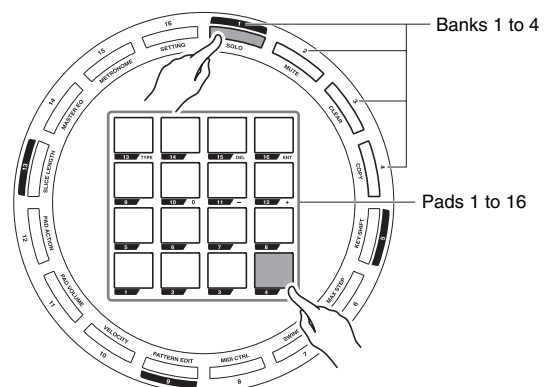

3. To cancel solo play, press the currently lit sequence step key or pad.

NOTE

- You can solo play multiple banks or pads.
- When all banks or pads are lit (indicating all are soloing), pressing any sequence step key or pad switches to solo play of the corresponding bank or pad only.

Muting a Particular Sound or Sounds

Use the procedure below when you want to mute all of the sounds in a bank or the sound of a particular pad in a bank.

1. Enter the MUTE mode.
2. Press the sequence step key that corresponds to the number of bank whose sounds you want to mute, or press the pad whose sound you want to mute.

This mutes the corresponding sound or sounds.

- The muted bank (sequence step key) or pad will become unlit.

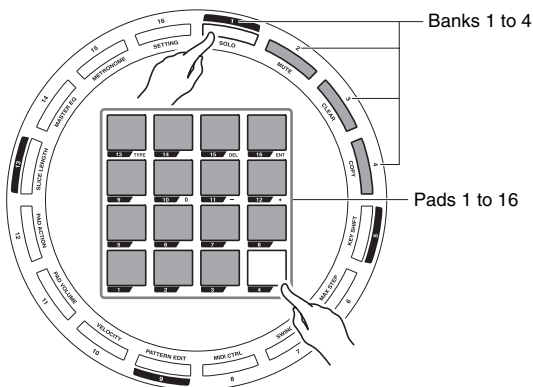

3. To cancel muting, press the currently unlit sequence step key or pad so it becomes lit.

Deleting Data

Use the procedures in this section to delete sequence, pattern, bank, and pad data.

To delete a sequence

1. Enter the CLEAR mode.
2. Press the **SEQ** selector button.

SEQ

3. Press pad 16 (**ENT**).
This deletes the sequence data.

To delete a pattern

1. Enter the CLEAR mode.
2. Press the **PATTERN** selector button.

Plt n

3. Press the sequence step key that corresponds to the number of the pattern you want to delete.

This will delete the pattern whose number matches that of the key you pressed.

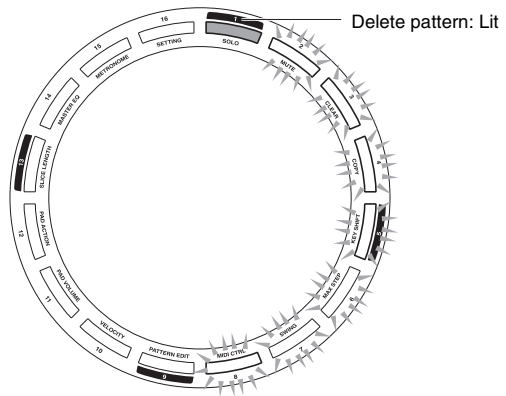

To delete bank settings

1. Enter the CLEAR mode.
2. Press the **PADSET** selector button.

SET

3. Press the sequence step key whose number corresponds to the bank you want to delete.

This deletes the sequence of the bank that corresponds to the sequence key you pressed and returns the tone and other settings to their initial defaults.

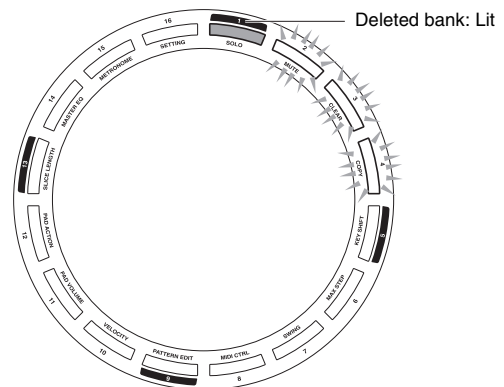

To delete pad settings

1. Enter the CLEAR mode.
2. Press the **PAD** selector button.

PAD

3. Press the pad you want to delete.

This deletes the settings of the pad and returns it to its initial settings.

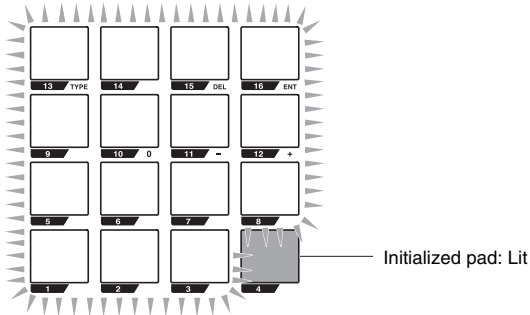

Copying Data

Use the procedures in this section to copy a pattern or bank. You can also copy pad setting contents.

To copy pattern contents

1. Enter the COPY mode.
2. Press the **PATTERN** selector button.

Pt n

3. While holding down the sequence step key that corresponds to the pattern number of the copy source, press the sequence step key that corresponds to the copy destination.
This copies the sequence to the destination pattern.

To copy bank contents

1. Enter the COPY mode.
2. Press the **PADSET** selector button.

SET

3. While holding down the sequence step key that corresponds to the bank number of the copy source, press the sequence step key that corresponds to the copy destination.
This copies the sequence to the destination bank.

To copy pad settings

1. Enter the COPY mode.
2. Press the **PAD** selector button.

PAD

3. While holding down the pad whose settings you want to copy, press the copy destination pad.
This copies tone and other settings to the destination pad.

Changing the Pitch of a Sequence

Use the procedures in this section to change the pitch of a sequence when all pad tones are note.

1. Enter the KEY SHIFT mode.

- You can check the current setting with the pad and screen.

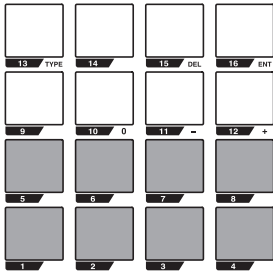

2. Use the pads to change the pitch.

Setting values: -7 (Pad 1) to 0 (Pad 8) to +8 (Pad 16)

- You can also use the VALUE knob to change the setting. With the VALUE knob, the setting range is -24 to +24.

NOTE

- You can change the pitch of each pattern in a pattern group (page EN-13). Select a pattern group and play back its sequence. While the pattern whose pitch you want to change is playing, perform the above steps to change it.

Pattern configuration:

1	4	3	4	1
---	---	---	---	---

Pitch:

+0	+2	+0	-2	-4
----	----	----	----	----

Changing the Number of Steps Per Measure

1. Enter the MAX STEP mode.

This will cause the sequence step key that corresponds to the number of steps to flash.

2. Press the sequence step key that corresponds to the number of steps you want to specify.

Setting values: 1 to 16 steps

- You can also use the VALUE knob to change the setting.

NOTE

- You can specify the number of steps setting for each pattern group (page EN-13). Select a pattern group and then perform the steps above to change the number of steps.

Applying a Swing Effect

1. Enter the SWING mode.

2. Use the pads to change the swing value.

Each pad changes the value as shown below.

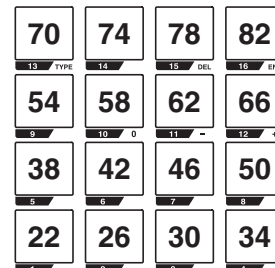

- You can also use the VALUE knob to change the setting. With the VALUE knob, the setting range is 0 to 100.

NOTE

- You can specify the swing value for each pattern group (page EN-13). Select a pattern group and then perform the steps above to change the swing value.

Entering the MIDI Control Mode

Entering the MIDI Control Mode stops sequence playback. A special application (Data Editor) can be used to configure assignments of pads, control buttons, etc. from your computer. For information about Data Editor, see “Saving and Loading TRACKFORMER Data to a Computer and Editing TRACKFORMER Data on a Computer” (page EN-23).

Sequence step keys	Navigates between pages 1 to 16. Changing to a different page changes the MIDI message output when a pad is pressed. <ul style="list-style-type: none"> The sequence step key that corresponds to the currently selected page flashes.
Pads, FX1 and FX2 knobs, ASSIGNABLE fader	Outputs MIDI messages assigned by the MIDI map. MIDI map assignments are configured with Data Editor.
PLAY button	Outputs play and pause MIDI messages.

Changing the Configuration of a Pattern

Patterns can be combined to create a sequence up to 16 measures long. Pressing the **PLAY** selector button plays a sequence in accordance with the configuration of the pattern created here. TRACKFORMER supports creation of up to four pattern combinations (pattern groups).

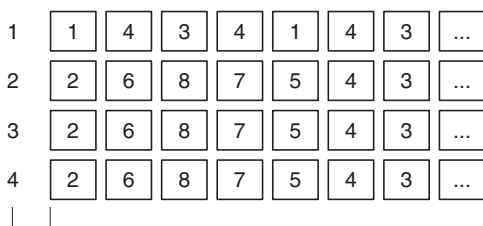

Pattern group numbers

Patterns

1. Press the **PATTERN** selector button.

2. Use the sequence step keys to select the number of the pattern group you want to edit.

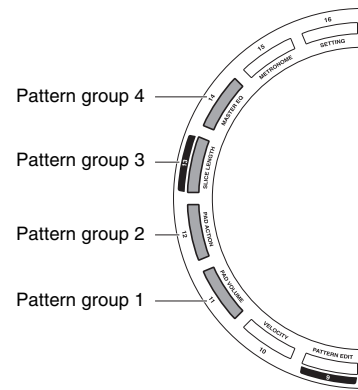

3. Enter the **PATTERN EDIT** mode.

4. Use the **VALUE** knob to change the number of measures.

Setting values: 1 to 16 measures

5. After pressing pad **1**, press the sequence step key that corresponds to the number of the pattern you want to use as measure 1.

This assigns the pattern to measure 1.

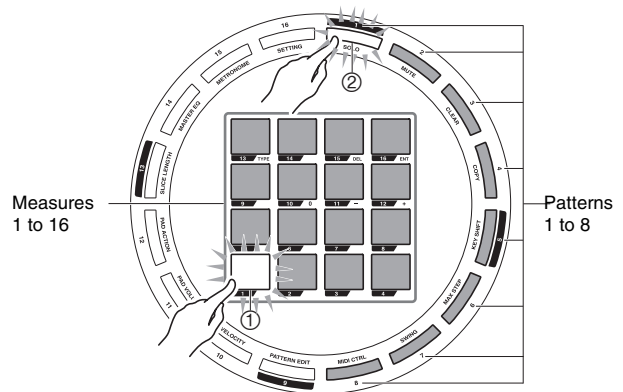

6. Repeat step 5 to assign patterns to the remaining measures.

Changing the Pad Velocity

You can use this setting to fix the volume level when a pad is tapped, or to change the volume level in accordance with how strongly the pad is tapped.

1. Enter the VELOCITY mode.
2. Press a sequence step key to change the velocity curve.

Sequence Step Key	Display Message	Setting
1	127	127 (fixed)
2	L in	Linear*
3	C-1	Curve 1*
4	C-2	Curve 2*
5	C-3	Curve 3*
12	20	20 (fixed)
13	40	40 (fixed)
14	60	60 (fixed)
15	80	80 (fixed)
16	100	100 (fixed)

* Amount of volume change when the pad is pressed increases in the following sequence (from least to most): Linear, Curve 1, Curve 2, Curve 3.

Changing the Pad Set Volume Level

You can specify a pad set volume level for each bank.

1. Enter the PAD VOLUME mode.

2. Use the pads to change the volume level of each bank.

Setting values: 0 to 127

- To make fine adjustments press any one of the pads in the bank you want to adjust. When the pad is flashing, use the VALUE knob to adjust the volume level.

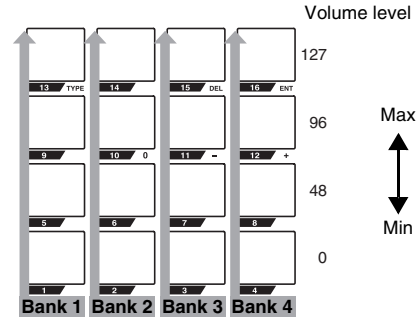

Changing the Operation of a Pad

Use the procedures in this section to specify how a sound should be produced when a pad is tapped.

To configure a pad for repeat play

1. Enter the PAD ACTION mode.
2. Press the pad you want to configure.
3. Use the sequence step keys to select a trigger timing.
 - Each press of a sequence step key toggles its trigger timing between enabled (flashing) and disabled (lit).
 - When a pad is configured not to repeat, all sequence step keys from 1 through 6 are lit.

Sequence Step Key	Display Message	Settings
1	32	1/32
2	16, 16t	1/16, 1/16T*
3	8, 8t	1/8, 1/8T*
4	4, 4t	1/4, 1/4T*
5	2, 2t	1/2, 1/2T*
6	1	1

* Each press of this type of sequence step key cycles the setting in the following sequence: Enabled (On) → Enabled (Triplicate) → Disabled (Off).

Grouping Pads

Sounding a grouped pad while the sound of another one of the group's pads is sounding will cause the previous pad's sound to stop. TRACKFORMER supports configuration of two groups per bank. This function is supported only while TRACKFORMER settings are configured as described below.

Tone type of all pads: Drum

Pad tones: Sound or sample

1. Enter the PAD ACTION mode.
2. Press a pad you want to include in the group.
3. Press sequence step key **8** (Group 1) or **9** (Group 2) to assign a group number.

This causes the sequence step key you pressed to flash and adds the pad you selected in step 2 to the group.

- To remove the pad from the group, press sequence step key **8** or **9** again so the key stops flashing and remains lit.

001 002

4. Repeat steps 2 and 3 to add other pads to the group.

Entering the TOGGLE Mode

You can configure a pad to remain depressed until you press it a second time.

1. Enter the PAD ACTION mode.
2. Press the pad you want to configure.
3. Press sequence step key **11** so it is flashing.

This puts the pad in the TOGGLE mode.

- Each press of sequence step key **11** toggles the TOGGLE mode between enabled (flashing) and disabled (lit).

EG1

Configuring the Effect Target

You can configure settings so effects are applied to a particular bank, or to the internal sound source or external sound source only.

NOTE

- This setting can be changed while the pad type is effect.

1. Enter the PAD ACTION mode.
2. Press the pad you want to configure.
3. Use the sequence step keys to select the effect target.

Setting	Display Message	Sequence Step Key Status	Description
All	ALL	13, 14, 15: Lit	Effects are applied to all sounds.
Current Bank	Cur	13: Flashing	Effects are applied to the currently selected bank only.
Internal	int	14: Flashing	Effects are applied to the internal sound source (Internal) or external sound source (External) only. Each press of this key cycles the setting in the following sequence: Internal sound source → External sound source → Disabled (Off).
External	Ext		
Bank 1	b1	15: Flashing	Select the bank to which you want to apply the effect. Each press of this key cycles the setting in the following sequence: Bank 1 → Bank 2 → Bank 3 → Bank 4 → Disabled (Off).
Bank 2	b2		
Bank 3	b3		
Bank 4	b4		

To change the sample playback method

NOTE

- This function can be used while the pad type is sample.

- Enter the PAD ACTION mode.
- Press the pad you want to configure.
- Use the sequence step keys to select a playback method.

Settings	Display Message	Sequence Step Key Status	Description
Gate	GT	13, 14: Lit	The sample is played once until the end, as long as the pad is kept depressed. Releasing the pad stops sample playback.
Loop	LP	13: Flashing	Sample playback repeats as long as the pad is depressed.
One-Shot	15	14: Flashing	Pressing the pad plays back the sample once, all the way through.

Changing the Initial Default Slice Length

Use the procedure below to change the initial default slice length to a value from 1 step to 16 steps.

- Enter the SLICE LENGTH mode.
A sequence step key will light to indicate the current slice length.
- Use the sequence step keys to change the slice length.

Using the Equalizer

Use the procedure below to adjust four equalizer frequency bands (HIGH, HIGH MID, LOW MID, LOW).

- Enter the MASTER EQ mode.
- Use the pads to raise or lower the four frequency bands.
 - Use the VALUE knob to make fine adjustments.
 - You can select a frequency band by pressing a pad, and then change the frequency to be adjusted by moving the ASSIGNABLE fader.



Selectable Frequencies

Band	Frequency
LOW	50Hz, 100Hz, 200Hz, 400Hz, 800Hz
LOW MID	100Hz, 250Hz, 630Hz, 1.3kHz, 4kHz
HIGH MID	250Hz, 630Hz, 1.3kHz, 4kHz, 8kHz
HIGH	6kHz, 8kHz, 10kHz, 13kHz, 16kHz

Using the Metronome

Entering the METRONOME mode causes the metronome to sound. To turn off the metronome, hold down the FUNCTION selector button again as you press sequence step key 15.

Configuring Other Settings

This section explains how to configure global TRACKFORMER and sequence settings.

Configuring Settings

1. While holding down the **FUNCTION** selector button, press sequence step key **16**.
2. Press the pad (**1** through **6**) that corresponds to the menu you want to access.
3. Press pad **16 (ENT)**.
This displays the menu you selected.
4. Press the pad that corresponds to the menu item you want to select.
This will cause the pad of the selected item to flash.
5. Press pad **16 (ENT)** to cycle through available settings.
 - You can also use the **VALUE** knob to change the displayed setting.
 - Pressing the **EXIT** button returns to the menu display in step 2 above.

Menu and Setting List

Pad Number, Display Message	Overview	Settings
1 SEqCOnFOn	Menu for configuring and saving settings for each sequence. These settings are not saved by the Auto Resume function.	
1 MAX IMizer	Maximizer. Adjusts overall sound pressure.	Off, 30, 60, 90*
2 REv SEND	Reverb Send. This parameter adjusts reverb.	0, 10, 20, 40, 80, 127*
2 SoUnd	Menu for configuring TRACKFORMER input and output audio settings.	
1 SP Out	Speaker Out. Off: Output from TRACKFORMER's speakers is disabled.	Off, On
2 STEREO	Stereo Imager. Outputs a stereo effect. A larger value increases the stereo effect.	Off, T01, T02, T03
3 n GATE	Noise Gate. On: External input sound below a fixed level is cut, which reduces noise.	Off, On
3 MIdI	Menu for configuring MIDI settings.	
1 LoCAL	Local Control. Off: No sound produced when a pad is tapped.	Off, On
2 MIdI	MIDI Control. On: MIDI message input and output is enabled.	Off, On

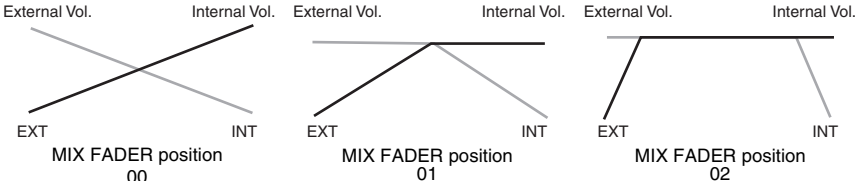
4	CTRL	Menu for configuring knob, fader, and button operation settings.	
1	CURVE	Fader Curve. Changes the fader curve of the MIX FADER. 	00, 01, 02
2	ASSIGN	Fader Assign. Assigns a function to the ASSIGNABLE fader. Off: No function assigned, SCR: Scratch effect, BND: Pitch bender effect, EFT: Effect	Off, SCR, BND, EFT
3	SCR WEIGHT	Scratch Weight. Specifies how the scratch effect (SCR) is applied when it is assigned to the ASSIGNABLE fader. LT: Effect fully applied with small fader movement. MID: Medium HVY: Not much effect applied even with large fader movement.	LT, MID, HVY
4	FX KNOB REF	Effect Knob Reflect. On: Applied effect depends on the current position of the FX1 or FX2 knob. Off: Applied effect is the last effect applied or the initial default effect.	Off, On
5	FX KNOB TGT	Effect Knob Target. Specifies the effects that are adjusted by the effect knob. All: All effects Lst: Last effect applied	All, Lst
6	REC CTRL	Record Controller. Specifies whether or not FX1 and FX2 knob operations are recorded.	Off, On
7	RESTART	Restart. On: Always starts playback from the beginning whenever sequence playback started by pressing the PLAY button. Off: Resumes playback from the location where playback last stopped.	Off, On
8	PAD FREEZE	Pad Freeze. Specifies whether or not to return pad tone settings to their initial defaults after all pad tones are changed. On: Settings are saved, Off: Returns to initial default settings <ul style="list-style-type: none"> When the pad tone type is one that cannot be selected by an all pad tone that was selected, all of the pad tones are returned to their initial defaults regardless of this setting. For example, if a pad's tone was changed to a sound and all pad tones were changed to melody type, the tones of all of the pads will be returned to their initial defaults, even if this setting is "On". 	Off, On
5	SAMPLING	Menu for configuring sampling settings.	
1	TEMP SYNC	Sampling Tempo Sync. On: Sampled sounds are synced with the sequence tempo when played back. The pitch of the sound also changes in accordance with the tempo. Off: Sampled sounds are always played back at their tempo when they were sampled. This function can be used while all pad tones are drum type, and the pad tones are samples.	Off, On
2	AUTO	Auto Sampling. Specifies the timing when sampling starts. On: Sampling starts upon sound input after the REC button is pressed. Off: Sampling starts as soon as the REC button is pressed. <ul style="list-style-type: none"> This setting is disabled automatically when the sampling pre-count setting (below) is enabled (On). 	Off, On
3	PRECOUNT	Sampling Pre-count. On: Sampling starts after a four-beat count.	Off, On
4	THRESH	Sampling Threshold. Sampling starts when the sound being sampled reaches a preset threshold level. This setting is valid only when the Auto Sampling setting (above) is enabled (On).	0-127
5	EXT ONLY	External Only. On: Only external sound sources are recorded.	Off, On

6 SYSTEM	Menu for configuring global TRACKFORMER settings.	
1 version	Version Information.	-
2 APo	Auto Power Off. On: TRACKFORMER turns off automatically if no operation is performed for a preset amount of time.	Off, On
3 RESUME	Auto Resume. On: TRACKFORMER remembers current settings when power is turned off, and restores them the next time power is turned on.	Off, On
4 init	All Initialize. Returns the system to its initial factory default state. Pressing pad 16 (ENT) causes "SUR" (Are you sure?) to appear on the display. Pressing pad 16 (ENT) again starts actual initialization.	-

* The VALUE knob can be used to change the setting value in a range of 0 to 127.

Adjusting Controller Operations

You can use the procedures in this section to adjust TRACKFORMER faders, knobs, pads, and other controllers whenever operations seem to be misaligned or otherwise different from what you expect.

Calibrating Knob and Fader Alignment

You can use this procedure to calibrate the positions of the knobs and faders below.

VALUE knob, FX1 knob, FX2 knob, MIX FADER, ASSIGNABLE fader

1. While holding down sequence step key **16**, press the **⏻** (power) button to turn on power.



2. Press sequence step key **1**.

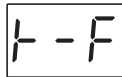

3. Press the **PLAY** selector button.

4. Rotate all of the above knobs to the left as far as they will go, and move the faders all the way to the left.

5. Press the **PLAY** selector button.

This will start calibration of the knob and fader operations to their far left positions.

- The message (rotate right) shown below will appear on the display when calibration is successful.

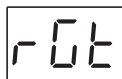

6. Rotate all of the above knobs to the right as far as they will go, and move the faders all the way to the right.

7. Press the **PLAY** selector button.

This will start calibration of the knob and fader operations to their far right positions.

- The message (center) shown below will appear on the display when calibration is successful.

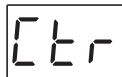

8. Move the **VALUE** knob, **MIX FADER**, and **ASSIGNABLE** fader to their center positions.

9. Press the **PLAY** selector button.

This will start calibration of knob and fader operations to their center positions.

- The message (End) shown below will appear on the display when calibration is complete.



10. Press the **⏻** (power) button to turn off TRACKFORMER.

NOTE

- To cancel calibration part way through, press the **EXIT** button. Canceling calibration part way through also discards any positions that were calibrated up to that point.
- An error message (Err) will appear if an error occurs during calibration. Pressing any button other than **EXIT** at this time will return to the previous display message. Make sure knobs and faders are in the correct positions (left, right, center) as you perform calibration again.

Adjusting Pad Sensitivity

Use the procedure below to adjust the sensitivity of a pad whenever you feel its velocity is different from that of other pads when tapped. Change to a smaller sensitivity value when the velocity of the pad is greater than that of other pads. Change to a larger sensitivity value when pad velocity is less than that of other pads.

- Settings: -99 to 0 to +99

1. While holding down sequence step key **16**, press the  (power) button to turn on power.

CL6

2. Press sequence step key **2**.

uEL

3. Tap the pad you want to adjust.

This will sound a drum sound and momentarily display the current velocity value. Next, the sensitivity value of the tapped pad will appear.

4. Use the **VALUE** knob to adjust the pad's sensitivity value.

5. Repeat steps 3 and 4 to adjust the sensitivity of other pads.

6. After adjustment of all the pads is the way you want, press the **PLAY** selector button.

The message (End) shown below will appear on the display when adjustment is complete.

End

7. Press the  (power) button to turn off TRACKFORMER.

NOTE

- To cancel adjustment part way through, press the **EXIT** button. Canceling adjustment part way through discards any adjustment you made up to that point.

Connecting to a Computer

Use the procedures in this section to connect TRACKFORMER to a computer and exchanges performance information (MIDI data). You can use Data Editor software on the computer to create sequences and to change TRACKFORMER settings.

Minimum Computer System Requirements

The following shows the minimum computer system requirements for sending and receiving MIDI data. Check to make sure that your computer complies with these requirements before connecting TRACKFORMER to it.

- Operating System
 - Windows Vista® *1
 - Windows® 7*2
 - Windows® 8 *3
 - Windows® 8.1 *4
 - Mac OS® X (10.3.9, 10.4.11, 10.5.X, 10.6.X, 10.7.X, 10.8.X, 10.9.X)
- *1: Windows Vista (32-bit)
- *2: Windows 7 (32-bit, 64-bit)
- *3: Windows 8 (32-bit, 64-bit)
- *4: Windows 8.1 (32-bit, 64-bit)
- USB port

IMPORTANT!

- Never connect to a computer that does not conform to the above requirements. Doing so can cause problems with your computer.

NOTE

- For the latest news about supported operating systems, visit the website at the URL below.
<http://world.casio.com/>

Connecting TRACKFORMER to Your Computer

IMPORTANT!

- Make sure you follow the steps of the procedure below exactly. Connecting incorrectly can make data send and receive impossible.

1. Turn off TRACKFORMER and then start up your computer.
 - Do not start up the music software on your computer yet!

2. After starting up your computer, use a commercially available USB cable to connect it to TRACKFORMER.

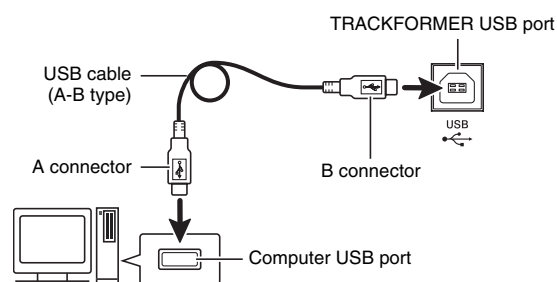

3. Turn on TRACKFORMER.

- If this is the first time you are connecting TRACKFORMER to your computer, the driver software required to send and receive data will be installed on your computer automatically.

4. Start up commercially available music software on your computer.

5. Configure the music software settings to select "CASIO USB-MIDI" as the MIDI device.

- For information about how to select the MIDI device, see the user documentation that comes with the music software you are using.

IMPORTANT!

- Be sure to turn on TRACKFORMER first before starting up your computer's music software.

NOTE

- Once you are able to connect successfully, there is no problem with leaving the USB cable connected when you turn off your computer and/or TRACKFORMER.
- For detailed specifications and connections that apply to MIDI data send and receive by this TRACKFORMER, see the latest support information provided by the website at the following URL.
<http://world.casio.com/>

Using MIDI

What is MIDI?

MIDI is a standard for digital signals and connectors that allows TRACKFORMER to exchange information with a computing device.

- For details about MIDI settings, see “Entering the MIDI Control Mode” on page EN-13, and “MIDI” under “Configuring Other Settings” on page EN-17.

Saving and Loading TRACKFORMER Data to a Computer and Editing TRACKFORMER Data on a Computer

You can also edit tone, pattern, and other TRACKFORMER data on a computer, where it is easier to work with.

A special Data Editor application is required in order to perform these operations.

1. Go to the CASIO WORLDWIDE site at the following URL.
<http://world.casio.com/>
 2. At the site, select a geographic area or country.
 3. After accessing the area site, navigate to the minimum computer system requirements for Data Editor for this product.
 - You should be able to find a link to Data Editor information on the product introduction page of this product. If you cannot find such a link, use the search form of the area site where you are located to enter the model name of this product and search for it.
 - Note that site contents are subject to change without notice.
 4. Check if your computer system complies with the minimum requirements for Data Editor.
 5. Download Data Editor and its user’s guide to your computer.
 6. Follow the procedure in the Data Editor user’s guide you downloaded in step 5 to install Data Editor.
7. Use the procedures in the Data Editor user’s guide to transfer and edit data.
 - See the Data Editor user’s guide for information about the types of data that can be transferred and the data that can be edited.

Appendix

Step Sequence List

No.	Display Name	Title	Tempo
0	EDM 1	Tokyo Magic	128
1	EDM 2	Force	128
2	EDM 3	Scoteria	128
3	EDM 4	Straight	128
4	TRAP 1	Lock	140
5	JUKE 1	Nuke	150
6	FOOTWORK 1	Workshop	150
7	FOOTWORK 2	Popwork	160
8	HIP-HOP 1	Gung Yeezy	86
9	HIP-HOP 2	Funkt	94
10	HIP-HOP 3	Jamhop	100
11	HIP-HOP 4	Korky	122
12	DUBSTEP 1	J-Dubstep	65
13	DUBSTEP 2	Dubman	140
14	TECHNO 1	Stance	150
15	TECHNO 2	Ramjam	139
16	SID BEATS 1	Sid Wilson (Slipknot) collection 1	140
17	SID BEATS 2	Sid Wilson (Slipknot) collection 2	100
18	CASIO VINTAGE 1	Casio Vintage 1	90
19	CASIO VINTAGE 2	Casio Vintage 2	140
20	EDM 5	Rain	135
21	EDM 6	Way-Out	128
22	EDM 7	Closed	138
23	EDM 8	Night Saber	128
24	TRAP 2	Jaxx	166
25	TRAP 3	Trapman	74
26	JUKE 2	King Juke	150
27	FOOTWORK 3	The Mac	145
28	FOOTWORK 4	Foot School	110
29	HIP-HOP 5	Ghangstah	80
30	HIP-HOP 6	Flowa	120
31	HIP-HOP 7	Funkathion	100
32	HIP-HOP 8	Booty Jam	96
33	HIP-HOP 9	Shameo	120
34	HIP-HOP 10	Ranking	100
35	HIP-HOP 11	Humanity	90
36	JUNGLE 1	UK Champion	170
37	JUNGLE 2	Jungle Town	160
38	JUNGLE 3	Breakthrough	180
39	GARAGE 1	Landan Trance	135
40	GARAGE 2	Max Garage	130
41	BREAKBEATS 1	Bedlam	96
42	BREAKBEATS 2	J-Breaks	120
43	BREAKBEATS 3	Rum Chop	134
44	BREAKBEATS 4	Beatbank	120
45	TECHNO 3	Shaqi	138
46	TECHNO 4	Barbara	126
47	TECHNO 5	Lean Jam	65
48	TECHNO 6	Kane Lock	130
49	TECHNO 7	kif	115

No.	Display Name	Title	Tempo
50	TECHNO 8	Quantro	125
51	TECHNO 9	Reconasio	140
52	TECHNO 10	Corn	140
53	TECHNO 11	Triplet	108
54	TECHNO 12	Resolve	160
55	TRANCE	Starry Sky	140
56	SOCA 1	Bolsca	130
57	SOCA 2	Acid	130
58	SOCA 3	lovelove	130
59	2STEP	Steprise	135
60	IDM 1	Syncop	126
61	IDM 2	Syner	125
62	IDM 3	Chopdem	130
63	TRIBAL 1	Ribalpop	100
64	TRIBAL 2	Tribalring	100
65	TRIBAL 3	Get Lost	144
66	SID BEATS 3	Sid Wilson (Slipknot) collection 3	120
67	SID BEATS 4	Sid Wilson (Slipknot) collection 4	120
68	SID BEATS 5	Sid Wilson (Slipknot) collection 5	120
69	SID BEATS 6	Sid Wilson (Slipknot) collection 6	93
70	SID BEATS 7	Sid Wilson (Slipknot) collection 7	120
71	SID BEATS 8	Sid Wilson (Slipknot) collection 8	120
72	VARIETY 1	Tabla	95
73	VARIETY 2	Latin Percussion	100
74	VARIETY 3	Samba	100
75	VARIETY 4	Reggae	80
76	VARIETY 5	Arabic Percussion	125
77	JAPAN 1	Bright	128
78	JAPAN 2	Toy Rocket	180
79	JAPAN 3	Try to Key	138
80	JAPAN 4	Marionette Dance	128
81	CHILLOUT 1	ChillOut 1	70
82	CHILLOUT 2	ChillOut 2	120
83	CHILLOUT 3	ChillOut 3	80
84	CASIO VINTAGE 3	Casio Vintage 3	140
85	CASIO VINTAGE 4	Casio Vintage 4	160
86	CASIO VINTAGE 5	Casio Vintage 5	120
87	CASIO VINTAGE 6	Casio Vintage 6	120
88	CASIO VINTAGE 7	Casio Vintage 7	120
89	CASIO VINTAGE 8	Casio Vintage 8	120
90	TEMPLATE 1	Template for EDM	128
91	TEMPLATE 2	Template for HIP-HOP	100
92	TEMPLATE 3	Template for JUKE/FOOTWORK	125
93	LOOP PLAY 1	Loop Play 1	90
94	LOOP PLAY 2	Loop Play 2	140
95	LOOP PLAY 3	Loop Play 3	120
96	EFFECT 1	Effect Setting 1	120
97	EFFECT 2	Effect Setting 2	120
98	EFFECT 3	Effect Setting 3	120
99	EFFECT 4	Effect Setting 4	120

Pad Set Tone List

Number	Bank	Prog	Display Name
SYNTH			
0	98	0	XW SoloSyn 1
1	98	1	XW SoloSyn 2
2	98	2	XW SoloSyn 3
3	98	3	XW SoloSyn 4
4	98	4	MM Raw Lead
5	98	5	XW SoloSyn 5
6	98	6	XW SoloSyn 6
7	98	7	XW SoloSyn 7
8	98	8	XW SoloSyn 8
9	98	9	MG Raw Lead
10	98	10	XW LeadSyn 1
11	98	11	XW LeadSyn 2
12	98	12	XW LeadSyn 3
13	98	13	XW LeadSyn 4
14	98	14	XW LeadSyn 5
15	98	15	XW LeadSyn 6
16	98	16	XW LeadSyn 7
17	98	17	CZ RawLead 1
18	98	18	CZ RawLead 2
19	98	19	CZ RawLead 3
20	98	20	PD1 Synth 1
21	98	21	PD1 Synth 2
22	98	22	PD1 Synth 3
23	98	23	PD1 Synth 4
24	98	24	PD1 Synth 5
25	98	25	PD1 Synth 6
26	98	26	PD1 Synth 7
27	98	27	PD1 Synth 8
28	98	28	PD1 Synth 9
29	98	29	PD1 Synth 10
30	98	30	PD1 Synth 11
31	98	31	PD1 Synth 12
32	98	32	PD1 Synth 13
33	98	33	PD1 Synth 14
34	98	34	PD1 Synth 15
35	98	35	PD1 Synth 16
36	98	36	VA Synth 1
37	98	37	VA Synth 2
38	98	38	VA Synth 3
39	98	39	VA Synth 4
40	98	40	VA Synth 5
41	98	41	VA Synth 6
42	98	42	VA Synth 7
43	98	43	XW SynBass 1
44	98	44	XW SynBass 2
45	98	45	XW SynBass 3
46	98	46	XW SynBass 4
47	98	47	XW SynBass 5
48	98	48	XW SynBass 6
49	98	49	XW SynBass 7
50	98	50	XW SynBass 8
51	98	51	DelaySawBass
52	98	52	TransAmbient
53	98	53	RetroSynBass
54	98	54	Retro Bass 1
55	98	55	Retro Bass 2
56	98	56	Retro Bass 3
57	98	57	Retro Bass 4
58	98	58	Retro Bass 5
59	98	59	Retro Bass 6

Number	Bank	Prog	Display Name
60	98	60	Retro Bass 7
61	98	61	Synth Hit 1
62	98	62	Synth Hit 2
63	98	63	VirtualWaves
64	98	64	WaveNation 1
65	98	65	WaveNation 2
66	98	66	WaveNation 3
67	98	67	WaveNation 4
68	98	68	WaveNation 5
69	98	69	WaveNation 6
70	98	70	HiPasfitLead
71	98	71	HiTresMotion
72	98	72	Motion Vox
73	98	73	AP Raw Lead
74	98	74	OB Raw Lead
75	98	75	P5 Raw Lead
76	98	76	ND Raw Lead
77	98	77	Whistler
78	98	78	Theremin Oct
79	98	79	Gaa-Gaa Saw
80	98	80	Transistory
81	98	81	TrezBandPass
82	98	82	Poncom Synth
83	98	83	FuzzyHarmnix
84	98	84	Triangle XMW
85	98	85	BellSineLead
86	98	86	PD1 Kick 1
87	98	87	PD1 Kick 2
88	98	88	PD1 Snare 1
89	98	89	PD1 Snare 2
90	98	90	PD1 Perc 1
91	98	91	PD1 Perc 2
92	98	92	PD1 Perc 3
93	98	93	PD1 Perc 4
94	98	94	PD1 Perc 5
95	98	95	PD1 Perc 6
96	98	96	PD1 Perc 7
97	98	97	PD1 Perc 8
98	98	98	PD1 Perc 9
99	98	99	Basic Sin
MELODY			
0	0	0	Grand Piano
1	0	1	Bright Piano
2	0	2	Rock Piano
3	4	1	Modern Piano
4	5	1	Dance Piano
5	8	0	StringsPiano
6	9	0	Piano Pad
7	0	3	HonkyTonk
8	0	6	Harpsichord
9	2	4	Elec Piano 1
10	1	5	FM E Piano
11	1	4	DynoE Piano
12	0	4	Elec Piano 2
13	0	5	Elec Piano 3
14	2	7	Clavi 1
15	3	7	Clavi 2
16	0	7	Clavi 3
17	2	11	Vibraphone 1
18	0	11	Vibraphone 2
19	0	8	Celesta

Number	Bank	Prog	Display Name
20	0	9	Glockenspiel
21	0	10	Music Box
22	0	12	Marimba
23	0	13	Xylophone
24	0	14	Tubular Bell
25	0	15	Dulcimer
26	0	16	DrawbarOrg 1
27	0	17	Perc Organ
28	6	16	Elec Organ
29	4	17	Jazz Organ
30	0	18	Rock Organ
31	5	18	Dist RockOrg
32	7	16	Full Drawbar
33	4	18	Rotary Organ
34	0	22	Harmonica
35	0	23	Bandoneon
36	4	48	Strings 1
37	0	49	Strings 2
38	0	48	Strings 3
39	1	48	StrEnsemble1
40	3	48	StrEnsemble2
41	0	50	Syn-Strings1
42	0	51	Syn-Strings2
43	1	50	70s Syn-Str
44	6	50	Fast Syn-Str
45	7	50	Slow Syn-Str
46	8	50	Syn-Strings3
47	8	51	Syn-Strings4
48	5	52	StringsVoice
49	0	54	Synth-Voice1
50	1	54	Synth-Voice2
51	4	54	VoiceEnsembl
52	0	52	Choir Aahs
53	0	53	Voice Doo
54	0	55	Orch Hit
55	0	40	Violin
56	0	42	Cello
57	0	43	Contrabas
58	0	44	Trem Strings
59	0	45	Pizzicato
60	0	46	Harp
61	0	47	Timpani
62	1	61	Brass 1
63	0	61	Brass 2
64	3	61	BrassSection
65	2	62	Synth-Brass1
66	3	62	Synth-Brass2
67	7	62	WarmSynBrass
68	1	62	80s SynBrass
69	4	62	A Syn-Brass
70	4	63	Trance Brass
71	0	62	Synth-Brass3
72	0	63	Synth-Brass4
73	0	56	Trumpet
74	0	57	Trombone
75	0	58	Tuba
76	0	59	Mute Trumpet
77	0	60	French Horn
78	0	64	Soprano Sax
79	0	65	Alto Sax
80	0	66	Tenor Sax
81	0	67	Baritone Sax
82	0	68	Oboe
83	0	69	English Horn

Number	Bank	Prog	Display Name
84	0	70	Bassoon
85	0	71	Clarinet
86	0	72	Piccolo
87	0	73	Flute
88	0	74	Recorder
89	0	75	Pan Flute
90	0	76	Bottle Blow
91	0	77	Shakuhach
92	0	78	Whistle
93	0	79	Ocarina
94	0	24	Nylon Guitar
95	0	25	Steel Guitar
96	0	27	CleanGuitar1
97	7	27	CleanGuitar2
98	0	28	Mute Guitar
99	0	29	Mute Ovd Gt
100	6	27	Crunch E Gt1
101	0	30	DistortionGt
102	4	30	More Dist Gt
103	0	26	Jazz Guitar
104	0	31	Gt Harmonics
105	2	32	Acous Bass 1
106	2	33	FingerBass 1
107	2	34	PickedBass 1
108	2	35	FretlesBass1
109	2	38	Synth-Bass 1
110	12	38	Synth-Bass 2
111	13	38	Synth-Bass 3
112	14	38	Synth-Bass 4
113	15	38	Synth-Bass 5
114	16	38	Synth-Bass 6
115	1	38	SawSyn-Bass1
116	9	38	SawSyn-Bass2
117	1	39	Sqr Syn-Bass
118	3	39	DigiRockBass
119	4	38	Trance Bass
120	5	39	Bs And Kick
121	3	38	Vocoder Bass
122	5	38	SoulSyn-Bass
123	0	32	Acous Bass 2
124	0	33	FingerBass 2
125	0	34	PickedBass 2
126	0	35	FretlesBass2
127	0	38	Synth-Bass 7
128	0	39	Synth-Bass 8
129	2	80	Square Lead1
130	1	80	Square Lead2
131	3	80	Square Lead3
132	15	80	Square Lead4
133	7	80	Sqr Pulse Ld
134	12	80	Sine Lead
135	2	81	Saw Lead 1
136	1	81	Saw Lead 2
137	3	81	Saw Lead 3
138	8	81	MelowSawLead
139	5	81	Pulse Saw Ld
140	4	81	SS Lead
141	5	80	Slow SqrLead
142	6	81	Slow SawLead
143	13	81	Saw Lead 4
144	11	80	Seq Square
145	13	80	Seq Pulse
146	10	80	SequenceSine
147	10	81	SequenceSaw1

Number	Bank	Prog	Display Name
148	11	81	SequenceSaw2
149	9	81	Trance Lead
150	16	80	VA SynthLead
151	17	80	VA Synth 1
152	18	80	VA Synth 2
153	19	80	VA Synth 3
154	20	80	VA Synth 4
155	21	80	VA Synth 5
156	22	80	VA Synth 6
157	23	80	VA Synth 7
158	24	80	VA Synth 8
159	16	81	VA Syn-SqBs1
160	17	81	VA Syn-SqBs2
161	18	81	VA Syn-SqBs3
162	19	81	VA Syn-SqBs4
163	20	81	VA Syn-SqBs5
164	22	81	VA Syn-Hit 1
165	23	81	VA Syn-Hit 2
166	5	82	Vent Lead
167	1	82	Vent Synth
168	7	82	SequenceLead
169	4	83	Drop Lead
170	1	83	EP Lead
171	2	85	Voice Lead 1
172	3	84	Pluck Lead 1
173	4	84	Pluck Lead 2
174	5	84	Gt SynthLead
175	7	85	DbIVoiceLead
176	4	85	VoiceChoirLd
177	6	85	Syn-Voice Ld
178	4	86	FifthSawLead
179	5	86	FifthSqrLead
180	6	86	Fifth Seq
181	3	87	SynBs And Ld
182	2	88	Fantasy 1
183	4	88	Fantasy 2
184	3	88	New Age
185	5	88	New Age Pad
186	8	89	Warm Vox
187	1	89	Thick Pad
188	2	89	Warm Pad 1
189	3	89	Sine Pad
190	4	89	Soft Pad
191	1	90	PolySynth 1
192	2	90	PolySynth 2
193	3	90	PolySynthPd1
194	5	90	PolySynthPd2
195	8	90	Poly Saw
196	1	91	Heaven
197	2	91	SpaceStrPad
198	5	91	Star Voice
199	0	92	Glass Pad
200	4	92	Bottle Pad
201	3	94	Halo Pad
202	1	94	Chorus Pad
203	1	95	Sweep Choir
204	1	96	Rain Drop 1
205	3	97	SoundTrack 1
206	1	98	XmasBell
207	5	98	Vibes Bell
208	1	100	BrightBellPd
209	2	100	Brightness 1
210	3	100	Brightness 2
211	3	102	Echo Drop

Number	Bank	Prog	Display Name
212	4	102	Poly Drop
213	0	80	Square Lead5
214	0	81	Saw Lead 4
215	0	82	Calliope
216	0	83	Chiff Lead
217	0	84	Charang
218	0	85	Voice Lead 2
219	0	86	Fifth Lead
220	0	87	Bs And Lead
221	0	88	Fantasy 3
222	0	89	Warm Pad 2
223	0	90	PolySynth 3
224	0	91	Space Choir
225	0	93	Metal Pad
226	0	94	Halo Pad
227	0	95	Sweep Pad
228	0	96	Rain Drop 2
229	0	97	SoundTrack 2
230	0	98	Crystal
231	0	99	Atmosphere
232	0	100	Brightness 3
233	0	101	Goblins
234	0	102	Echoes
235	0	103	SF
236	0	104	Sitar
237	16	104	Tanpura
238	0	105	Banjo
239	0	106	Shamisen
240	0	107	Koto
241	0	109	Bagpipe
242	0	110	Fiddle
243	0	111	Shanai
244	0	113	Agogo
245	0	114	Steel Drums
246	0	115	Wood Block
247	0	116	Taiko
248	0	117	Melodic Tom
249	0	118	Synth-Drum
DRUM			
0	120	29	Dance Set 1
1	120	9	Hip-Hop Set
2	120	25	Synth Set 1
3	120	54	Groove Set 1
4	120	24	Elec Set
5	120	31	Trance Set
6	120	0	StandardSet1
7	120	8	Room Set
8	120	16	Power Set
9	120	32	Jazz Set
10	120	30	Synth Set 2
11	120	28	Dance Set 2
12	120	55	Groove Set 2
13	120	49	Ethnic Set 1
14	120	50	Ethnic Set 2

Pad Tone List

■ Tone Type: Sound

No.	Display Name	No.	Display Name	No.	Display Name	No.	Display Name	No.	Display Name	No.	Display Name
0	Blank Inst	60	Kick 60	120	Snare 6	180	Snare 66	240	Snare 126	300	Tom 22
1	Kick 1	61	Kick 61	121	Snare 7	181	Snare 67	241	Snare 127	301	Tom 23
2	Kick 2	62	Kick 62	122	Snare 8	182	Snare 68	242	Snare 128	302	Tom 24
3	Kick 3	63	Kick 63	123	Snare 9	183	Snare 69	243	Snare 129	303	Tom 25
4	Kick 4	64	Kick 64	124	Snare 10	184	Snare 70	244	Snare 130	304	Tom 26
5	Kick 5	65	Kick 65	125	Snare 11	185	Snare 71	245	Snare 131	305	Tom 27
6	Kick 6	66	Kick 66	126	Snare 12	186	Snare 72	246	Snare 132	306	Tom 28
7	Kick 7	67	Kick 67	127	Snare 13	187	Snare 73	247	Snare 133	307	Tom 29
8	Kick 8	68	Kick 68	128	Snare 14	188	Snare 74	248	Snare 134	308	Tom 30
9	Kick 9	69	Kick 69	129	Snare 15	189	Snare 75	249	Snare 135	309	Tom 31
10	Kick 10	70	Kick 70	130	Snare 16	190	Snare 76	250	Snare 136	310	Tom 32
11	Kick 11	71	Kick 71	131	Snare 17	191	Snare 77	251	Snare 137	311	Tom 33
12	Kick 12	72	Kick 72	132	Snare 18	192	Snare 78	252	Snare 138	312	Tom 34
13	Kick 13	73	Kick 73	133	Snare 19	193	Snare 79	253	Snare 139	313	Tom 35
14	Kick 14	74	Kick 74	134	Snare 20	194	Snare 80	254	Snare 140	314	Tom 36
15	Kick 15	75	Kick 75	135	Snare 21	195	Snare 81	255	Snare 141	315	Tom 37
16	Kick 16	76	Kick 76	136	Snare 22	196	Snare 82	256	Snare 142	316	Tom 38
17	Kick 17	77	Kick 77	137	Snare 23	197	Snare 83	257	Snare 143	317	Tom 39
18	Kick 18	78	Kick 78	138	Snare 24	198	Snare 84	258	Snare 144	318	Tom 40
19	Kick 19	79	Kick 79	139	Snare 25	199	Snare 85	259	Snare 145	319	Tom 41
20	Kick 20	80	Kick 80	140	Snare 26	200	Snare 86	260	Snare 146	320	Tom 42
21	Kick 21	81	Kick 81	141	Snare 27	201	Snare 87	261	Snare 147	321	Tom 43
22	Kick 22	82	Kick 82	142	Snare 28	202	Snare 88	262	Side Stick 1	322	Tom 44
23	Kick 23	83	Kick 83	143	Snare 29	203	Snare 89	263	Side Stick 2	323	Tom 45
24	Kick 24	84	Kick 84	144	Snare 30	204	Snare 90	264	Side Stick 3	324	Tom 46
25	Kick 25	85	Kick 85	145	Snare 31	205	Snare 91	265	Side Stick 4	325	Tom 47
26	Kick 26	86	Kick 86	146	Snare 32	206	Snare 92	266	Side Stick 5	326	Tom 48
27	Kick 27	87	Kick 87	147	Snare 33	207	Snare 93	267	Side Stick 6	327	Tom 49
28	Kick 28	88	Kick 88	148	Snare 34	208	Snare 94	268	Side Stick 7	328	Tom 50
29	Kick 29	89	Kick 89	149	Snare 35	209	Snare 95	269	Side Stick 8	329	Tom 51
30	Kick 30	90	Kick 90	150	Snare 36	210	Snare 96	270	Side Stick 9	330	Tom 52
31	Kick 31	91	Kick 91	151	Snare 37	211	Snare 97	271	Hand Clap 1	331	Tom 53
32	Kick 32	92	Kick 92	152	Snare 38	212	Snare 98	272	Hand Clap 2	332	Tom 54
33	Kick 33	93	Kick 93	153	Snare 39	213	Snare 99	273	Hand Clap 3	333	Tom 55
34	Kick 34	94	Kick 94	154	Snare 40	214	Snare 100	274	Hand Clap 4	334	Tom 56
35	Kick 35	95	Kick 95	155	Snare 41	215	Snare 101	275	Hand Clap 5	335	Tom 57
36	Kick 36	96	Kick 96	156	Snare 42	216	Snare 102	276	Hand Clap 6	336	Tom 58
37	Kick 37	97	Kick 97	157	Snare 43	217	Snare 103	277	Hand Clap 7	337	Tom 59
38	Kick 38	98	Kick 98	158	Snare 44	218	Snare 104	278	Hand Clap 8	338	Tom 60
39	Kick 39	99	Kick 99	159	Snare 45	219	Snare 105	279	Tom 1	339	Tom 61
40	Kick 40	100	Kick 100	160	Snare 46	220	Snare 106	280	Tom 2	340	Tom 62
41	Kick 41	101	Kick 101	161	Snare 47	221	Snare 107	281	Tom 3	341	Tom 63
42	Kick 42	102	Kick 102	162	Snare 48	222	Snare 108	282	Tom 4	342	Tom 64
43	Kick 43	103	Kick 103	163	Snare 49	223	Snare 109	283	Tom 5	343	Tom 65
44	Kick 44	104	Kick 104	164	Snare 50	224	Snare 110	284	Tom 6	344	Tom 66
45	Kick 45	105	Kick 105	165	Snare 51	225	Snare 111	285	Tom 7	345	Tom 67
46	Kick 46	106	Kick 106	166	Snare 52	226	Snare 112	286	Tom 8	346	Tom 68
47	Kick 47	107	Kick 107	167	Snare 53	227	Snare 113	287	Tom 9	347	Tom 69
48	Kick 48	108	Kick 108	168	Snare 54	228	Snare 114	288	Tom 10	348	Tom 70
49	Kick 49	109	Kick 109	169	Snare 55	229	Snare 115	289	Tom 11	349	Tom 71
50	Kick 50	110	Kick 110	170	Snare 56	230	Snare 116	290	Tom 12	350	Tom 72
51	Kick 51	111	Kick 111	171	Snare 57	231	Snare 117	291	Tom 13	351	Tom 73
52	Kick 52	112	Kick 112	172	Snare 58	232	Snare 118	292	Tom 14	352	Tom 74
53	Kick 53	113	Kick 113	173	Snare 59	233	Snare 119	293	Tom 15	353	Tom 75
54	Kick 54	114	Kick 114	174	Snare 60	234	Snare 120	294	Tom 16	354	Tom 76
55	Kick 55	115	Snare 1	175	Snare 61	235	Snare 121	295	Tom 17	355	Tom 77
56	Kick 56	116	Snare 2	176	Snare 62	236	Snare 122	296	Tom 18	356	Tom 78
57	Kick 57	117	Snare 3	177	Snare 63	237	Snare 123	297	Tom 19	357	Tom 79
58	Kick 58	118	Snare 4	178	Snare 64	238	Snare 124	298	Tom 20	358	Tom 80
59	Kick 59	119	Snare 5	179	Snare 65	239	Snare 125	299	Tom 21	359	Hi-Hat 1

No.	Display Name	No.	Display Name	No.	Display Name	No.	Display Name	No.	Display Name	No.	Display Name
360	Hi-Hat 2	424	Hi-Hat 66	488	Tambourin 1	552	Timpani G#2	616	Riq Tik 2	680	Bass Sound 8
361	Hi-Hat 3	425	Hi-Hat 67	489	Tambourin 2	553	Timpani A2	617	Riq Slap	681	Bass Sound 9
362	Hi-Hat 4	426	Hi-Hat 68	490	Tambourin 3	554	Timpani A#2	618	Riq Jingle	682	Bass Sound10
363	Hi-Hat 5	427	Hi-Hat 69	491	Tambourin 4	555	Timpani B2	619	Zill Close	683	Bass Sound11
364	Hi-Hat 6	428	Hi-Hat 70	492	Tambourin 5	556	Timpani C3	620	Zill Open	684	Bass Sound12
365	Hi-Hat 7	429	Hi-Hat 71	493	Tambourin 6	557	Timpani C#3	621	OrientlClaps	685	Bass Sound13
366	Hi-Hat 8	430	Hi-Hat 72	494	Tambourin 7	558	Timpani D3	622	Davul L	686	Bass Sound14
367	Hi-Hat 9	431	Hi-Hat 73	495	Tambourin 8	559	Timpani D#3	623	Davul H	687	Bass Sound15
368	Hi-Hat 10	432	Hi-Hat 74	496	Tambourin 9	560	Timpani E3	624	Davul Rim	688	One-Shot 1
369	Hi-Hat 11	433	Hi-Hat 75	497	Tambourin 10	561	Timpani F3	625	Daf Dum	689	One-Shot 2
370	Hi-Hat 12	434	Hi-Hat 76	498	Tambourin 11	562	Tabla Ge	626	Daf Tek	690	One-Shot 3
371	Hi-Hat 13	435	Hi-Hat 77	499	Tambourin 12	563	Tabla Ka	627	Daf Ring 1	691	One-Shot 4
372	Hi-Hat 14	436	Hi-Hat 78	500	Tambourin 13	564	Tabla Te	628	Daf Ring 2	692	One-Shot 5
373	Hi-Hat 15	437	Hi-Hat 79	501	Cowbell 1	565	Tabla Na	629	Tombak Dum	693	One-Shot 6
374	Hi-Hat 16	438	Hi-Hat 80	502	Cowbell 2	566	Tabla Tun	630	Tombak Bak	694	One-Shot 7
375	Hi-Hat 17	439	Hi-Hat 81	503	Cowbell 3	567	Dholak Ge	631	Tombak Snap	695	One-Shot 8
376	Hi-Hat 18	440	RideCymbal 1	504	Cowbell 4	568	Dholak Ke	632	Drum Loop 1	696	One-Shot 9
377	Hi-Hat 19	441	RideCymbal 2	505	Vibraslap	569	Dholak Ta 1	633	Drum Loop 2	697	One-Shot 10
378	Hi-Hat 20	442	RideCymbal 3	506	Bongo 1	570	Dholak Ta 2	634	Drum Loop 3	698	One-Shot 11
379	Hi-Hat 21	443	RideCymbal 4	507	Bongo 2	571	Dholak Na	635	Drum Loop 4	699	One-Shot 12
380	Hi-Hat 22	444	RideCymbal 5	508	Bongo 3	572	Dholak Ta 3	636	Drum Loop 5	700	One-Shot 13
381	Hi-Hat 23	445	RideCymbal 6	509	Bongo 4	573	Dholak Ring	637	Drum Loop 6	701	One-Shot 14
382	Hi-Hat 24	446	RideCymbal 7	510	Conga 1	574	MridangamTha	638	Drum Loop 7	702	One-Shot 15
383	Hi-Hat 25	447	RideCymbal 8	511	Conga 2	575	MridangmDhom	639	Drum Loop 8	703	One-Shot 16
384	Hi-Hat 26	448	RideCymbal 9	512	Conga 3	576	MridangamDhi	640	Drum Loop 9	704	One-Shot 17
385	Hi-Hat 27	449	RideCymbal10	513	Conga 4	577	MridangmDhin	641	Drum Loop 10	705	One-Shot 18
386	Hi-Hat 28	450	RideCymbal11	514	Conga 5	578	MridangamNum	642	Drum Loop 11	706	One-Shot 19
387	Hi-Hat 29	451	RideCymbal12	515	Conga 6	579	Ban Gu	643	Audio Loop 1	707	One-Shot 20
388	Hi-Hat 30	452	RideCymbal13	516	High Timbale	580	Hu Yin Luo	644	Audio Loop 2	708	One-Shot 21
389	Hi-Hat 31	453	RideCymbal14	517	Low Timbale	581	Xiao Luo	645	Audio Loop 3	709	One-Shot 22
390	Hi-Hat 32	454	CrashCymbal1	518	High Agogo	582	Xiao Bo	646	Audio Loop 4	710	One-Shot 23
391	Hi-Hat 33	455	CrashCymbal2	519	Low Agogo	583	Low Tang Gu	647	Audio Loop 5	711	One-Shot 24
392	Hi-Hat 34	456	CrashCymbal3	520	Cabasa 1	584	Mid Tang Gu	648	Audio Loop 6	712	One-Shot 25
393	Hi-Hat 35	457	CrashCymbal4	521	Cabasa 2	585	High Tang Gu	649	Audio Loop 7	713	One-Shot 26
394	Hi-Hat 36	458	CrashCymbal5	522	Maracas 1	586	Tablah 1	650	Audio Loop 8	714	One-Shot 27
395	Hi-Hat 37	459	CrashCymbal6	523	Maracas 2	587	Tablah 2	651	Audio Loop 9	715	Voice 1
396	Hi-Hat 38	460	CrashCymbal7	524	Maracas 3	588	Tablah 3	652	Audio Loop10	716	Voice 2
397	Hi-Hat 39	461	CrashCymbal8	525	ShrHiWhistl	589	Daf 1	653	Audio Loop11	717	Voice 3
398	Hi-Hat 40	462	CrashCymbal9	526	LongLoWhistl	590	Daf 2	654	Audio Loop12	718	Voice 4
399	Hi-Hat 41	463	CrashCymbal10	527	Short Guiro	591	Riq 1	655	Audio Loop13	719	Voice 5
400	Hi-Hat 42	464	CrashCymbal11	528	Long Guiro	592	Riq 2	656	Audio Loop14	720	Voice 6
401	Hi-Hat 43	465	CrashCymbal12	529	Claves 1	593	Riq 3	657	Audio Loop15	721	Voice 7
402	Hi-Hat 44	466	CrashCymbal13	530	Claves 2	594	Davul 1	658	Audio Loop16	722	Voice 8
403	Hi-Hat 45	467	CrashCymbal14	531	Claves 3	595	Davul 2	659	Audio Loop17		
404	Hi-Hat 46	468	CrashCymbal15	532	Hi WoodBlock	596	Zill 1	660	Audio Loop18		
405	Hi-Hat 47	469	CrashCymbal16	533	LowWoodBlock	597	Zill 2	661	Audio Loop19		
406	Hi-Hat 48	470	CrashCymbal17	534	Mute Cuica	598	Darbuka Dum	662	Audio Loop20		
407	Hi-Hat 49	471	CrashCymbal18	535	Open Cuica	599	Darbuka Tek	663	Audio Loop21		
408	Hi-Hat 50	472	CrashCymbal19	536	MuteTriangl1	600	Darbuka Slap	664	Audio Loop22		
409	Hi-Hat 51	473	CrashCymbal20	537	OpenTriangl1	601	Darbuka Tik1	665	Audio Loop23		
410	Hi-Hat 52	474	CrashCymbal21	538	MuteTriangl2	602	Darbuka Tik2	666	Audio Loop24		
411	Hi-Hat 53	475	CrashCymbal22	539	OpenTriangl2	603	DarbukTekRol	667	Audio Loop25		
412	Hi-Hat 54	476	High Q	540	Shaker 1	604	DarbukTekFil	668	Audio Loop26		
413	Hi-Hat 55	477	Slap	541	Shaker 2	605	Bendir Dum 1	669	Audio Loop27		
414	Hi-Hat 56	478	Square Click	542	Jingle Bell	606	Bendir Dum 2	670	Audio Loop28		
415	Hi-Hat 57	479	Synth Click1	543	Bell Tree	607	Bendir Tek 1	671	Audio Loop29		
416	Hi-Hat 58	480	Synth Click2	544	Castanets	608	Bendir Tek 2	672	Audio Loop30		
417	Hi-Hat 59	481	Sticks	545	Mute Surdo	609	Bendir Slap1	673	Bass Sound 1		
418	Hi-Hat 60	482	Metron.Click	546	Open Surdo	610	Bendir Slap2	674	Bass Sound 2		
419	Hi-Hat 61	483	Metron.Bell	547	Applause 1	611	Riq Dum 1	675	Bass Sound 3		
420	Hi-Hat 62	484	Scratch Push	548	Applause 2	612	Riq Dum 2	676	Bass Sound 4		
421	Hi-Hat 63	485	Scratch Pull	549	Timpani F2	613	Riq Tek 1	677	Bass Sound 5		
422	Hi-Hat 64	486	HpHpScratch1	550	Timpani F#2	614	Riq Tek 2	678	Bass Sound 6		
423	Hi-Hat 65	487	HpHpScratch2	551	Timpani G2	615	Riq Tik 1	679	Bass Sound 7		

■ Tone Type: Phrase

No.	Display Name	No.	Display Name	No.	Display Name	No.	Display Name	No.	Display Name
0	SynthPhrase1	20	Strings 4	40	Latin EP	60	PlagalCadnce	80	Hi-HatPhrase
1	SynthPhrase2	21	Minor Ballad	41	Bossa Guitar	61	Chord Prg 1	81	PD1 Phrase 1
2	SynthPhrase3	22	Pop Ballad	42	Bossa Piano	62	Chord Prg 2	82	PD1 Phrase 2
3	SynthPhrase4	23	CrunchStrum1	43	Reggae Bass	63	Chord Prg 3	83	PD1 Phrase 3
4	SynthPhrase5	24	CrunchStrum2	44	EthnicPhrase	64	Synth Up	84	PD1 Phrase 4
5	Drum Loop	25	16ShflStrum1	45	OneKey Percs	65	Synth Down	85	PD1 Phrase 5
6	Vocoder Bass	26	16ShflStrum2	46	ClassicPhr 1	66	Synth Seq 1	86	PD1 Phrase 6
7	SynthPhrase6	27	BW Lok Bass	47	ClassicPhr 2	67	Synth Seq 2	87	PD1 Phrase 7
8	FastArpeggio	28	ShflRockBass	48	ClassicPhr 3	68	Synth Seq 3	88	PD1 Phrase 8
9	Minimal 1	29	80s Rock	49	Fantasy Arp	69	Synth Seq 4	89	PD1 Phrase 9
10	Minimal 2	30	80sSynPhrase	50	Chromatic	70	Synth Seq 5	90	PD1 Phrase10
11	African	31	Rock Guitar	51	Diminish Arp	71	Synth Seq 6	91	PD1 Phrase11
12	LA Piano	32	Minor Rock	52	Dominant Arp	72	80sSynthBs 2	92	PD1 Phrase12
13	CleanGuitar1	33	Sus4 Rock	53	4th Phrase	73	Simple SynBs	93	PD1 Phrase13
14	CleanGuitar2	34	Prog Bass	54	Penta Arp Up	74	SequenceBass	94	PD1 Phrase14
15	80sSynthBs 1	35	Blues Solo	55	PentaArpDown	75	Poppin Synth	95	PD1 Phrase15
16	Funk EP	36	Slap Bass 1	56	Pedal Point	76	SoloSynPhr 1	96	PD1 Phrase16
17	Strings 1	37	Slap Bass 2	57	MinorTriplet	77	SoloSynPhr 2	97	PD1 Phrase17
18	Strings 2	38	Fill-In 1	58	Minor Arp	78	Kick Phrase	98	PD1 Phrase18
19	Strings 3	39	Fill-In 2	59	Voice	79	Snare Phrase	99	PD1 Phrase19



NOTE

- Performance information is recorded in phrases. Playback is performed using the tone selected by the bank of the assigned pad.
- You can use Data Editor to convert an existing music file (SMF: Standard MIDI File) to a format that can be used by TRACKFORMER. For information about Data Editor, see page EN-23.

DrumSet No. →	6	0	1	2	3	4	5	7	8	9	10	11	12	13	14
KEY	STANDARD SET 1	DANCE SET 1	HIP-HOP SET	SYNTH SET 1	GROOVE SET 1	ELECTRONIC SET	TRANCE SET	ROOM SET	POWER SET	JAZZ SET	SYNTH SET 2	DANCE SET 2	GROOVE SET 2	ETHNIC SET 1	ETHNIC SET 2
C6	Bell Tree	Hip-Hop Kick 3	←	←	Hip-Hop Kick 3	←	←	←	←	←	←	←	Hip-Hop Kick 3	Midangum Dhom	
D6	Castanets	Standard Kick 1	←	←	Standard Kick 1	←	←	←	←	←	←	←	Standard Kick 1	Midangum Dhi	Dawul
E6	Open Suido	Hand Clap 1	←	←	Hand Clap 1	←	←	←	←	←	←	←	Standard Snare 1	Midangum Nuh	Dawl Rim
E6	Applause 1	Standard Snare 2	←	←	Standard Snare 2	←	←	←	←	←	←	←	Standard Snare 2	Midangum Num	Dal Rim
F6	Applause 2	Elec.Low Tom 2	←	←	Elec.Low Tom 2	←	←	←	←	←	←	←	Elec.Low Tom 2	Ban Gu	Dal Ring
F6		Hip-Hop Closed Hi-Hat	←	←	Hip-Hop Closed Hi-Hat	←	←	←	←	←	←	←	Hip-Hop Closed Hi-Hat	Hu Yin Luo	Dal Ring 2
G6		Elec.Low Tom 1	←	←	Elec.Low Tom 1	←	←	←	←	←	←	←	Elec.Low Tom 1	Xiao Luo	Tomback Dum
A6		Hip-Hop Pedal Hi-Hat	←	←	Hip-Hop Pedal Hi-Hat	←	←	←	←	←	←	←	Hip-Hop Pedal Hi-Hat	Xiao Luo	Tomback Bak
A6		Elec.Mid Tom 2	←	←	Elec.Mid Tom 2	←	←	←	←	←	←	←	Elec.Mid Tom 2	Xiao Bo	Tomback Nap
B6		Hip-Hop Open Hi-Hat	←	←	Hip-Hop Open Hi-Hat	←	←	←	←	←	←	←	Hip-Hop Open Hi-Hat	High Tang Gu	
B6		Elec.Mid Tom 1	←	←	Elec.Mid Tom 1	←	←	←	←	←	←	←	Elec.Mid Tom 1	High Tang Gu	
C7		Elec.High Tom 2	←	←	Elec.High Tom 2	←	←	←	←	←	←	←	Elec.High Tom 2	High Tang Gu	
C7		Techno Cymbal	←	←	Techno Cymbal	←	←	←	←	←	←	←	Techno Cymbal		
D7		Elec.High Tom 1	←	←	Elec.High Tom 1	←	←	←	←	←	←	←	Elec.High Tom 1		
E7		Techno Ride	←	←	Techno Ride	←	←	←	←	←	←	←	Techno Ride		
E7			←	←		←	←	←	←	←	←	←			
F7		Low Tom 2	←	←	Low Tom 2	←	←	←	←	←	←	←	Low Tom 2		
F7		Closed Hi-Hat	←	←	Closed Hi-Hat	←	←	←	←	←	←	←	Closed Hi-Hat		
G7		Open Hi-Hat	←	←	Open Hi-Hat	←	←	←	←	←	←	←	Open Hi-Hat		
A7		Pedal Hi-Hat	←	←	Pedal Hi-Hat	←	←	←	←	←	←	←	Pedal Hi-Hat		
A7		Mid Tom 2	←	←	Mid Tom 2	←	←	←	←	←	←	←	Mid Tom 2		
B7		Open Hi-Hat	←	←	Open Hi-Hat	←	←	←	←	←	←	←	Open Hi-Hat		
B7		Mid Tom 1	←	←	Mid Tom 1	←	←	←	←	←	←	←	Mid Tom 1		
C8		High Tom 2	←	←	High Tom 2	←	←	←	←	←	←	←	High Tom 2		
C8		High Tom 1	←	←	High Tom 1	←	←	←	←	←	←	←	High Tom 1		
C8		Crash Cymbal 1	←	←	Crash Cymbal 1	←	←	←	←	←	←	←	Crash Cymbal 1		
C8		High Tom 1	←	←	High Tom 1	←	←	←	←	←	←	←	High Tom 1		
D8		Ride Cymbal 1	←	←	Ride Cymbal 1	←	←	←	←	←	←	←	Ride Cymbal 1		
D8			←	←		←	←	←	←	←	←	←			
E8		Tombourne 2	←	←	Tombourne 2	←	←	←	←	←	←	←	Tombourne 2		
E8		Tombourne 3	←	←	Tombourne 3	←	←	←	←	←	←	←	Tombourne 3		
F8		Calassa 2	←	←	Calassa 2	←	←	←	←	←	←	←	Calassa 2		
F8		Maracas 2	←	←	Maracas 2	←	←	←	←	←	←	←	Maracas 2		
F8		Claves 2	←	←	Claves 2	←	←	←	←	←	←	←	Claves 2		
G8		Mute Triangle 2	←	←	Mute Triangle 2	←	←	←	←	←	←	←	Mute Triangle 2		
G8		Open Triangle 2	←	←	Open Triangle 2	←	←	←	←	←	←	←	Open Triangle 2		
A8		Shaker 2	←	←	Shaker 2	←	←	←	←	←	←	←	Shaker 2		
A8		Hand Clap 2	←	←	Hand Clap 2	←	←	←	←	←	←	←	Hand Clap 2		
B8			←	←		←	←	←	←	←	←	←			
B8			←	←		←	←	←	←	←	←	←			
C9			←	←		←	←	←	←	←	←	←			
C9			←	←		←	←	←	←	←	←	←			
D9			←	←		←	←	←	←	←	←	←			
D9			←	←		←	←	←	←	←	←	←			
E9			←	←		←	←	←	←	←	←	←			
E9			←	←		←	←	←	←	←	←	←			
F9			←	←		←	←	←	←	←	←	←			
F9			←	←		←	←	←	←	←	←	←			
G9			←	←		←	←	←	←	←	←	←			

• “←” indicates a key is assigned the same tones as it is for STANDARD SET 1.

Effect List

No.	Display Name	Full Name	Block A	Block B	Block C	Block D	FX 1 Knob	FX 2 Knob	ASSIGNABLE Fader	Velocity
0	LPF	Low Pass Filter	-	Filter	-	-	Cutoff	Resonance	Fade-in Speed	-
1	HPF	High Pass Filter	-	Filter	-	-	Cutoff	Resonance	Fade-in Speed	-
2	BPF	Band Pass Filter	-	Filter	-	-	Cutoff	Resonance	Fade-in Speed	-
3	LHPF	Low/High Pass Filter	-	Filter	-	-	Cutoff	Resonance	Fade-in Speed	-
4	LPF-Low	LPF (Low Band Only)	-	Filter	-	-	Cutoff	Resonance	Fade-in Speed	-
5	LPF-Mid	LPF (Middle Band Only)	-	Filter	-	-	Cutoff	Resonance	Fade-in Speed	-
6	LPF-High	LPF (High Band Only)	-	Filter	-	-	Cutoff	Resonance	Fade-in Speed	-
7	HPF-Low	HPF (Low Band Only)	-	Filter	-	-	Cutoff	Resonance	Fade-in Speed	-
8	HPF-Mid	HPF (Middle Band Only)	-	Filter	-	-	Cutoff	Resonance	Fade-in Speed	-
9	HPF-High	HPF (High Band Only)	-	Filter	-	-	Cutoff	Resonance	Fade-in Speed	-
10	BPF-Low	BPF (Low Band Only)	-	Filter	-	-	Cutoff	Resonance	Fade-in Speed	-
11	BPF-Mid	BPF (Middle Band Only)	-	Filter	-	-	Cutoff	Resonance	Fade-in Speed	-
12	BPF-High	BPF (High Band Only)	-	Filter	-	-	Cutoff	Resonance	Fade-in Speed	-
13	Fadein-LPF	Fade-in LPF	-	Filter	-	-	Cutoff	Fade-in Speed	Resonance	-
14	Fadein-HPF	Fade-in HPF	-	Filter	-	-	Cutoff	Fade-in Speed	Resonance	-
15	Fadein-BPF	Fade-in BPF	-	Filter	-	-	Cutoff	Fade-in Speed	Resonance	-
16	Velo-LPF	Velocity LPF	-	Filter	-	-	Cutoff	Resonance	Fade-in Speed	Cutoff
17	Velo-HPF	Velocity HPF	-	Filter	-	-	Cutoff	Resonance	Fade-in Speed	Cutoff
18	LFO-LPF	LFO LPF	-	Filter	-	-	LFO Speed	LFO Depth, Cutoff	Resonance	-
19	LFO-HPF	LFO HPF	-	Filter	-	-	LFO Speed	LFO Depth, Cutoff	Resonance	-
20	Random-LPF	Random LFO LPF	-	Filter	-	-	LFO Speed	LFO Depth, Cutoff	Resonance	-
21	Random-HPF	Random LFO HPF	-	Filter	-	-	LFO Speed	LFO Depth, Cutoff	Resonance	-
22	SawUp-LPF	Saw-up LFO LPF	-	Filter	-	-	LFO Speed	LFO Depth, Cutoff	Resonance	-
23	SawDown-LPF	Saw-down LFO LPF	-	Filter	-	-	LFO Speed	LFO Depth, Cutoff	Resonance	-
24	SawUp-HPF	Saw-up LFO HPF	-	Filter	-	-	LFO Speed	LFO Depth, Cutoff	Resonance	-
25	SawDown-HPF	Saw-down LFO HPF	-	Filter	-	-	LFO Speed	LFO Depth, Cutoff	Resonance	-
26	Roll	Roll	Roll	-	-	-	Frequency	-	-	-
27	Roll-1_1	Roll 1/1beat	Roll	-	-	-	-	-	-	-
28	Roll-1_2	Roll 1/2beat	Roll	-	-	-	-	-	-	-
29	Roll-1_4	Roll 1/4beat	Roll	-	-	-	-	-	-	-
30	Roll-1_8	Roll 1/8beat	Roll	-	-	-	-	-	-	-
31	Roll-1_16	Roll 1/16beat	Roll	-	-	-	-	-	-	-
32	Roll-2_3	Roll 2/3beat	Roll	-	-	-	-	-	-	-
33	Roll-1_3	Roll 1/3beat	Roll	-	-	-	-	-	-	-
34	Roll-1_6	Roll 1/6beat	Roll	-	-	-	-	-	-	-
35	Async-Roll	Asynchronous Roll	Roll	-	-	-	Frequency	-	-	-
36	Overdub	Overdub Roll	Roll	-	-	-	Frequency	Overdub	-	-
37	Velo-Overdub	Velocity Overdub Roll	Roll	-	-	-	Frequency	Overdub	-	Overdub
38	Chopper	Chopper	Roll	-	-	-	Frequency	Retrigger	-	-
39	Mech-Sound	Mechanical Sound	Roll	-	-	-	Overdub	Feedback	Retrigger	-
40	Beep	Beep	Roll	-	-	-	Frequency	-	-	-
41	Rvs-Roll	Reverse Roll	Reverse Roll	-	-	-	Frequency	-	-	-
42	Rvs-Roll-1	Reverse Roll 1beat	Reverse Roll	-	-	-	-	-	-	-
43	Rvs-Roll-2	Reverse Roll 2beat	Reverse Roll	-	-	-	-	-	-	-
44	Rvs-Roll-4	Reverse Roll 4beat	Reverse Roll	-	-	-	-	-	-	-
45	Rvs-Play	Reverse Play	Reverse Roll	-	-	-	Frequency	Overdub	Feedback	-
46	Async-Rvs	Asynchronous Reverse Roll	Reverse Roll	-	-	-	Frequency	-	-	-
47	Step-Back1	Step Back 1	Step Back	-	-	-	Transform	Keep	-	-
48	Step-Back2	Step Back 2	Step Back	-	-	-	Transform	Keep	-	-
49	Step-Back3	Step Back 3	Step Back	-	-	-	Transform	Keep	-	-
50	Step-Back4	Step Back 4	Step Back	-	-	-	Transform	Keep	-	-
51	Step-Back5	Step Back 5	Step Back	-	-	-	Transform	Keep	-	-
52	Step-Back6	Step Back 6	Step Back	-	-	-	Transform	Keep	-	-
53	Step-Back7	Step Back 7	Step Back	-	-	-	Transform	Keep	-	-
54	Step-Back8	Step Back 8	Step Back	-	-	-	Transform	Keep	-	-
55	Step-Back9	Step Back 9	Step Back	-	-	-	Transform	Keep	-	-
56	Step-Back10	Step Back 10	Step Back	-	-	-	Transform	Keep	-	-
57	Step-Back11	Step Back 11	Step Back	-	-	-	Transform	Keep	-	-
58	Step-Back12	Step Back 12	Step Back	-	-	-	Transform	Keep	-	-
59	Step-Back13	Step Back 13	Step Back	-	-	-	Transform	Keep	-	-
60	Step-Back14	Step Back 14	Step Back	-	-	-	Transform	Keep	-	-
61	Step-Back15	Step Back 15	Step Back	-	-	-	Transform	Keep	-	-
62	Step-Back16	Step Back 16	Step Back	-	-	-	Transform	Keep	-	-
63	Step-Back17	Step Back 17	Step Back	-	-	-	Transform	Keep	-	-
64	Return-1	Return 1beat	Step Back	-	-	-	-	-	-	-
65	Return-2	Return 2beat	Step Back	-	-	-	-	-	-	-
66	Return-4	Return 4beat	Step Back	-	-	-	-	-	-	-
67	Tape-Stop	Tape Stop	Tape Stop	-	-	-	Deceleration, Acceleration	-	-	-
68	Fast-Stop	Fast Tape Stop	Tape Stop	-	-	-	Deceleration, Acceleration	-	-	-
69	Slow-Stop	Slow Tape Stop	Tape Stop	-	-	-	Deceleration, Acceleration	-	-	-
70	Decel-Only	Slow Fall Tape Stop	Tape Stop	-	-	-	Deceleration	-	-	-
71	Accel-Only	Slow Rise Tape Stop	Tape Stop	-	-	-	Acceleration	-	-	-
72	Flanger	Flanger	-	Flanger	-	-	LFO Speed	LFO Depth	Feedback	-
73	Hard-Flanger	Hard Flanger	-	Flanger	-	-	LFO Speed	LFO Depth	Feedback	-

No.	Display Name	Full Name	Block A	Block B	Block C	Block D	FX 1 Knob	FX 2 Knob	ASSIGNABLE Fader	Velocity
74	Up-Flanger	Saw-up LFO Flanger	-	Flanger	-	-	LFO Speed	LFO Depth	Feedback	-
75	Down-Flanger	Saw-down LFO Flanger	-	Flanger	-	-	LFO Speed	LFO Depth	Feedback	-
76	Velo-Flanger	Velocity Flanger	-	Flanger	-	-	LFO Speed	LFO Depth	Feedback	LFO Depth
77	Manu-Flanger	Manual Flanger	-	Flanger	-	-	LFO Depth	Feedback	-	-
78	Tremolo	Tremolo	-	Tremolo	-	-	LFO Speed	LFO Depth	-	-
79	Pump-Soft	Soft Pump-up Tremolo	-	Tremolo	-	-	LFO Speed	LFO Depth	-	-
80	Pump-Mid	Middle Pump-up Tremolo	-	Tremolo	-	-	LFO Speed	LFO Depth	-	-
81	Pump-Hard	Hard Pump-up Tremolo	-	Tremolo	-	-	LFO Speed	LFO Depth	-	-
82	Gater1	Gater 1	-	Gater	-	-	Speed	-	-	-
83	Gater2	Gater 2	-	Gater	-	-	Speed	-	-	-
84	Gater3	Gater 3	-	Gater	-	-	Speed	-	-	-
85	Gater4	Gater 4	-	Gater	-	-	Speed	-	-	-
86	Gater5	Gater 5	-	Gater	-	-	Speed	-	-	-
87	Gater6	Gater 6	-	Gater	-	-	Speed	-	-	-
88	Gater7	Gater 7	-	Gater	-	-	Speed	-	-	-
89	Gater8	Gater 8	-	Gater	-	-	Speed	-	-	-
90	Gater9	Gater 9	-	Gater	-	-	Speed	-	-	-
91	Gater10	Gater 10	-	Gater	-	-	Speed	-	-	-
92	Ratio-Gater	Ratio Gater	-	Gater	-	-	Speed	Pattern Length	-	-
93	Pitch-Shift	Pitch Shift	-	Pitch Shifter	-	-	Pitch	Dry Level, Wet Level	Fade-in Speed	-
94	Pitch-Chroma	Chromatic Pitch Shift	-	Pitch Shifter	-	-	Pitch	Dry Level, Wet Level	Fade-in Speed	-
95	Harmo-Up-3rd	Harmonize (3rd above)	-	Pitch Shifter	-	-	Dry Level	Wet Level	Pitch	-
96	Harmo-Up-5th	Harmonize (5th above)	-	Pitch Shifter	-	-	Dry Level	Wet Level	-	-
97	Harmo-Up-Oct	Harmonize (1 octave above)	-	Pitch Shifter	-	-	Dry Level	Wet Level	-	-
98	Harmo-Lo-4th	Harmonize (4th below)	-	Pitch Shifter	-	-	Dry Level	Wet Level	-	-
99	Harmo-Lo-6th	Harmonize (6th below)	-	Pitch Shifter	-	-	Dry Level	Wet Level	Pitch	-
100	Harmo-Lo-Oct	Harmonize (1 octave below)	-	Pitch Shifter	-	-	Dry Level	Wet Level	-	-
101	Vibrato	Vibrato	-	Pitch Shifter	-	-	LFO Speed	LFO Depth	-	-
102	Velo-Vibrato	Velocity Vibrato	-	Pitch Shifter	-	-	LFO Speed	LFO Depth	-	LFO Depth
103	Pitch-SawUp	Pitch Shift with Saw-up LFO	-	Pitch Shifter	-	-	LFO Speed	LFO Depth	Dry Level, Wet Level	-
104	Pitch-SawDw	Pitch Shift with Saw-down LFO	-	Pitch Shifter	-	-	LFO Speed	LFO Depth	Dry Level, Wet Level	-
105	Distortion	Distortion	-	Distortion	-	-	Depth, Output Level	-	-	-
106	Soft-Dist	Soft Distortion	-	Distortion	-	-	Depth, Output Level	-	-	-
107	Hard-Dist	Hard Distortion	-	Distortion	-	-	Depth, Output Level	-	-	-
108	Muffled-Dist	Muffled Distortion	-	Distortion	-	-	Depth	-	-	-
109	Velo-Dist	Velocity Distortion	-	Distortion	-	-	Depth, Output Level	-	-	Depth, Output Level
110	Decimation	Decimation	-	Crusher	-	-	Decimation	-	-	-
111	Soft-Decim	Soft Decimation	-	Crusher	-	-	Decimation	-	-	-
112	Velo-Decim	Velocity Decimation	-	Crusher	-	-	Decimation	-	-	Decimation
113	Bit-Crush	Bit Crush	-	Crusher	-	-	Bit Crush	-	-	-
114	Ring-Mod	Ring Modulation	-	Ring Modulator	-	-	OSC Frequency	Dry Level, Wet Level	-	-
115	Ring-Low	Ring Modulation (Low Frequency)	-	Ring Modulator	-	-	OSC Frequency	Dry Level, Wet Level	-	-
116	Ring-High	Ring Modulation (High Frequency)	-	Ring Modulator	-	-	OSC Frequency	Dry Level, Wet Level	-	-
117	Velo-Ring	Velocity Ring Modulation	-	Ring Modulator	-	-	OSC Frequency	Dry Level, Wet Level	-	Dry Level, Wet Level
118	Noise	Noise	-	Noise Generator	-	-	Noise Level	LPF Cutoff, HPF Cutoff	Input Level	-
119	Noise-Low	Noise (Low Frequency)	-	Noise Generator	-	-	Noise Level	LPF Cutoff	Input Level	-
120	Noise-High	Noise (High Frequency)	-	Noise Generator	-	-	Noise Level	HPF Cutoff	Input Level	-
121	Noise-Only	Noise Only	-	Noise Generator	-	-	Noise Level	LPF Cutoff	HPF Cutoff	-
122	Velo-Noise	Velocity Noise	-	Noise Generator	-	-	Noise Level	LPF Cutoff, HPF Cutoff	Input Level	Noise Level
123	LFO-Noise	LFO Noise	-	Noise Generator	-	-	LFO Speed	LFO Depth, LPF Cutoff	Noise Level	-
124	Pump-Noise1	Soft Pump-up Noise	-	Noise Generator	-	-	LFO Speed	LFO Depth, LPF Cutoff	Noise Level	-
125	Pump-Noise2	Middle Pump-up Noise	-	Noise Generator	-	-	LFO Speed	LFO Depth, LPF Cutoff	Noise Level	-
126	Pump-Noise3	Hard Pump-up Noise	-	Noise Generator	-	-	LFO Speed	LFO Depth, LPF Cutoff	Noise Level	-
127	Random-Noise	Random LFO Noise	-	Noise Generator	-	-	LFO Speed	LFO Depth, HPF Cutoff	Noise Level	-
128	Wavy-Noise	Wavy Noise	-	Noise Generator	-	-	Noise Level	LFO Speed	LFO Depth	-
129	Rainy-Noise	Rainy Noise	-	Noise Generator	-	-	Noise Level	LPF Cutoff	HPF Cutoff	-
130	Auto-Pan	Auto Pan	-	-	-	Panner	-	LFO Speed	LFO Depth	-
131	Solid-Pan	Solid (Square) LFO Pan	-	-	-	Panner	-	LFO Speed	LFO Depth	-
132	L2R	Left to Right	-	-	-	Panner	-	LFO Speed	LFO Depth	-
133	R2L	Right to Left	-	-	-	Panner	-	LFO Speed	LFO Depth	-
134	Random-Pan	Random LFO Pan	-	-	-	Panner	-	LFO Speed	LFO Depth	-
135	Velo-Pan	Velocity Auto Pan	-	-	-	Panner	-	LFO Speed	LFO Depth	LFO Speed
136	Manual-Pan	Manual Pan	-	-	-	Panner	Center	-	-	-
137	Stereo-Delay	Stereo Delay	-	-	-	Delay	-	Time	Feedback Level	Wet Level
138	Mono-Delay	Monaural Delay	-	-	-	Delay	-	Time	Feedback Level	Wet Level
139	PingPong-L	Ping-Pong Delay (Start from Left)	-	-	-	Delay	-	Time	Feedback Level	Wet Level
140	PingPong-R	Ping-Pong Delay (Start from Right)	-	-	-	Delay	-	Time	Feedback Level	Wet Level
141	Short-Delay	Short Delay	-	-	-	Delay	-	Time Ratio L, Time Ratio R	Feedback Level	Wet Level
142	Doubling	Doubling	-	-	-	Delay	-	Feedback Level	Feedback Damp	Wet Level
143	Loud-Delay	Loud Delay	-	-	-	Delay	-	Time	Feedback Level	Wet Level
144	Velo-Delay	Velocity Delay	-	-	-	Delay	-	Time	Feedback Level	Wet Level
145	Long-Delay	Long Delay	Roll	-	-	-	Frequency	Feedback	-	-
146	Room-Reverb	Room Reverb	-	-	-	Reverb	Level	Time	-	-
147	Hall-Reverb	Hall Reverb	-	-	-	Reverb	Level	Time	-	-
148	Stadium-Rvb	Stadium Reverb	-	-	-	Reverb	Level	Time	-	-
149	Loud-Reverb	Loud Reverb	-	-	-	Reverb	Level	Time	-	-
150	Velo-Reverb	Velocity Reverb	-	-	-	Reverb	Level	Time	-	Level, Time

No.	Display Name	Full Name	Block A	Block B	Block C	Block D	FX 1 Knob	FX 2 Knob	ASSIGNABLE Fader	Velocity
151	PitchUp-Roll	Saw-up LFO Pitch Shift + Roll	Roll	Pitch Shifter	–	–	Roll Frequency, Pitch Shifter LFO Speed	Pitch Shifter Pitch, Pitch Shifter LFO Depth	Pitch Shifter Dry Level	–
152	PitchDw-Roll	Saw-down LFO Pitch Shift + Roll	Roll	Pitch Shifter	–	–	Roll Frequency, Pitch Shifter LFO Speed	Pitch Shifter Pitch, Pitch Shifter LFO Depth	Pitch Shifter Dry Level	–
153	LPF-Up-Roll	Saw-up LFO LPF + Roll	Roll	Filter	–	–	Roll Frequency, Pitch Shifter LFO Speed	Filter Cutoff, Filter LFO Depth	Filter Resonance	–
154	LPF-Dw-Roll	Saw-down LFO LPF + Roll	Roll	Filter	–	–	Roll Frequency, Pitch Shifter LFO Speed	Filter Cutoff, Filter LFO Depth	Filter Resonance	–
155	Flg-Up-Roll	Saw-up LFO Flanger + Roll	Roll	Flanger	–	–	Roll Frequency, Pitch Shifter LFO Speed	Flanger LFO Depth	Flanger Feedback	–
156	Flg-Dw-Roll	Saw-down LFO Flanger + Roll	Roll	Flanger	–	–	Roll Frequency, Pitch Shifter LFO Speed	Flanger LFO Depth	Flanger Feedback	–
157	Vol-Up-Roll	Saw-up Tremolo + Roll	Roll	Tremolo	–	–	Roll Frequency, Pitch Shifter LFO Speed	Tremolo LFO Depth	–	–
158	Vol-Dw-Roll	Saw-down Tremolo + Roll	Roll	Tremolo	–	–	Roll Frequency, Pitch Shifter LFO Speed	Tremolo LFO Depth	–	–
159	Pump-Roll1	Soft Pump-up Tremolo + Roll	Roll	Tremolo	–	–	Roll Frequency, Pitch Shifter LFO Speed	Tremolo LFO Depth	–	–
160	Pump-Roll2	Middle Pump-up Tremolo + Roll	Roll	Tremolo	–	–	Roll Frequency, Pitch Shifter LFO Speed	Tremolo LFO Depth	–	–
161	Pump-Roll3	Hard Pump-up Tremolo + Roll	Roll	Tremolo	–	–	Roll Frequency, Pitch Shifter LFO Speed	Tremolo LFO Depth	–	–
162	Gater-Roll1	Gater + Roll 1	Roll	Gater	–	–	Roll Frequency, Gater Speed	–	–	–
163	Gater-Roll2	Gater + Roll 2	Roll	Gater	–	–	Roll Frequency, Gater Speed	–	–	–
164	Gater-Roll3	Gater + Roll 3	Roll	Gater	–	–	Roll Frequency, Gater Speed	–	–	–
165	Gater-Roll4	Gater + Roll 4	Roll	Gater	–	–	Roll Frequency, Gater Speed	–	–	–
166	Gater-Roll5	Gater + Roll 5	Roll	Gater	–	–	Roll Frequency, Gater Speed	–	–	–
167	LR-Roll	Square LFO Pan + Roll	Roll	–	Panner	–	Roll Frequency, Panner LFO Speed	Panner LFO Depth	–	–
168	LR-Reverse	Square LFO Pan + Reverse Roll	Roll	–	Panner	–	Roll Frequency, Panner LFO Speed	Panner LFO Depth	–	–
169	Rnd-Pan-Roll	Random LFO Pan + Roll	Roll	–	Panner	–	Roll Frequency, Panner LFO Speed	Panner LFO Depth	–	–
170	Dist-Roll	Distortion + Roll	Roll	Distortion	–	–	Roll Frequency	Distortion Depth, Distortion Output Level	Distortion Tone Color	–
171	Decim-Roll	Decimation + Roll	Roll	Crusher	–	–	Roll Frequency	Crusher Decimation	–	–
172	Ring-Roll	Ring Modulation + Roll	Roll	Ring Modulator	–	–	Roll Frequency	Ring Modulator OSC Frequency	–	–
173	Destruct1	Destruct 1	–	Distortion	Crusher	–	Distortion Depth, Distortion Output Level, Distortion Tone Color, Crusher Decimation	–	–	–
174	Destruct2	Destruct 2	–	Ring Modulator	Distortion	–	Ring Modulator OSC Frequency, Ring Modulator Dry Level, Ring Modulator Wet Level, Distortion Depth, Distortion Output Level, Distortion Tone Color	–	–	–
175	Destruct3	Destruct 3	–	Ring Modulator	Crusher	–	Ring Modulator Dry Level, Ring Modulator Wet Level, Crusher Decimation, Crusher Bit Crush	–	–	–
176	Wobbler1	Wobbler 1	Roll	Filter	–	–	Filter LFO Speed	Filter Resonance	Roll Frequency	–
177	Wobbler2	Wobbler 2	Roll	Filter	–	–	Filter LFO Speed	Filter Resonance	Roll Frequency	–
178	Wobbler3	Wobbler 3	Roll	Flanger	Filter	–	Flanger LFO Speed, Filter LFO Speed	Flanger Feedback Filter Resonance	Roll Frequency	–
179	Wobbler4	Wobbler 4	Roll	Filter	Distortion	–	Filter LFO Speed	Distortion Depth, Distortion Output Level	Roll Frequency	–
180	Wobbler5	Wobbler 5	Roll	Crusher	Filter	–	Filter LFO Speed	Crusher Decimation, Filter Resonance	Roll Frequency	–
181	Echo-Break	Echo Break	Roll	–	–	–	Frequency	Feedback	–	–
182	LPF-Break	LPF Break	Tape Stop	Filter	–	–	Filter Fade-in Speed	Filter Resonance	–	–
183	Trem-Break	Tremolo Break	Tape Stop	Tremolo	–	–	Tape Stop Deceleration	Tremolo LFO Speed	Tremolo LFO Depth	–
184	Gater-Break	Gater Break	Tape Stop	Gater	–	–	Tape Stop Deceleration	Gater Speed	–	–
185	Vib-Break	Vibrato Break	Tape Stop	Pitch Shifter	–	–	Tape Stop Deceleration	Pitch Shifter LFO Speed	Pitch Shifter LFO Depth	–
186	Delay-Break	Delay Break	Tape Stop	Delay	–	–	Delay Feedback Level, Delay Feedback Damp	–	–	–
187	Reverb-Break	Reverb Break	Tape Stop	–	–	Reverb	Tape Stop Deceleration, Reverb Time	Reverb Level	–	–
188	Jet	Jet	–	Noise Generator	Flanger	–	Flanger LFO Depth	Flanger Feedback	Noise Generator Noise Level	–
189	LFO-Jet	LFO Jet	–	Noise Generator	Flanger	–	Flanger LFO Depth	Flanger Feedback	Noise Generator Noise Level	–
190	Reso-Noise	Resonance Noise	–	Noise Generator	Filter	–	Filter Cutoff	Filter Resonance	Noise Generator Noise Level	–
191	LFO-Reso-Nz	LFO Resonance Noise	–	Noise Generator	Filter	–	Filter Cutoff, Filter LFO Speed	Filter LFO Depth	Noise Generator Noise Level	–
192	Gater-Delay	Gater + Delay	–	Gater	Delay	–	Gater Speed	Delay Time	Delay Feedback Damp	–
193	Up-and-Down	Up and Down	–	Flanger	Filter	–	Flanger LFO Speed, Filter LFO Speed	Flanger LFO Depth, Filter LFO Depth	Flanger Feedback	–
194	Instable	Instable	Roll	Tremolo	–	–	Frequency, LFO Speed	LFO Depth	Feedback, Overdub	–
195	Flg-Gater	Flanger + Gater	–	Flanger	Gater	–	Flanger LFO Speed	Flanger LFO Depth	Flanger LFO Type	–
196	Ring-Filter	Ring Modulation + Filter	–	Ring Modulator	Filter	–	Ring Modulator OSC Frequency, Filter Cutoff	Filter Resonance	Ring Modulator Wet Level	–
197	Pitch-Filter	Pitch Shift + Filter	–	Pitch Shifter	Filter	–	Pitch Shifter Pitch, Filter Cutoff	Filter Resonance	–	–
198	Mute	Mute	–	Gater	–	–	–	–	–	–
199	LFO-Scratch	LFO Scratch	LFO Scratch	–	–	–	LFO Speed	LFO Depth	LFO Type	–

Signal Diagram

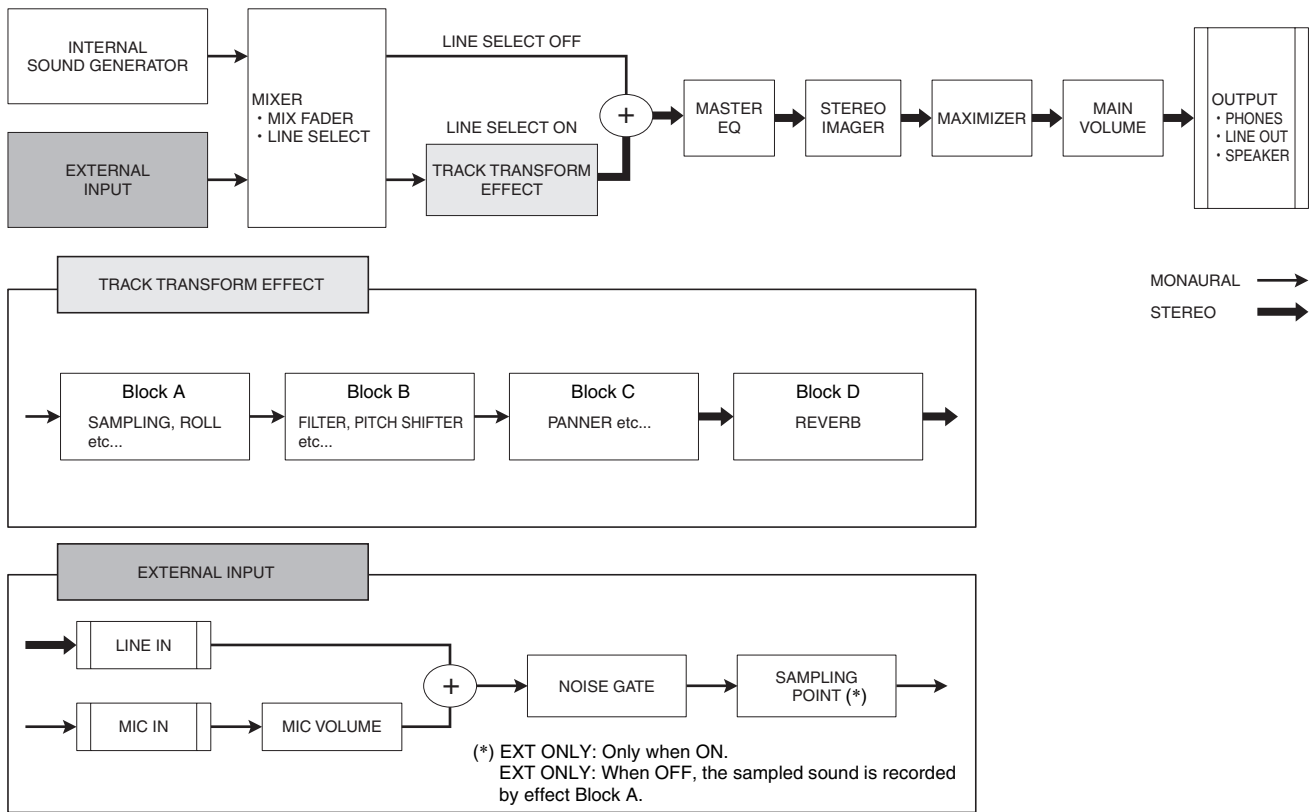

Internal Sound Source Operation Flow

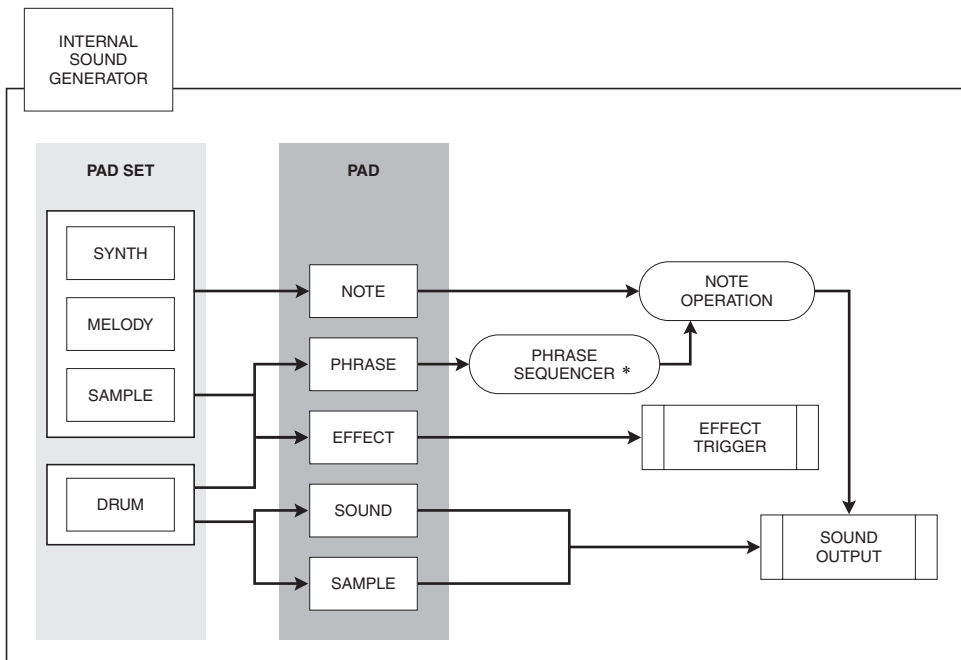

* Up to four phrase sequencers can be played simultaneously.

MIDI Implementation Chart

Function	Transmitted	Recognized	Remarks
Basic Channel Default Changed	1 - 4 1 - 16	1 - 16 1 - 16	
Mode Default Messages Altered	Mode 3 X * * * * * * * * * *	Mode 3 X * * * * * * * * * *	
Note Number True voice	0 - 127 * * * * * * * * * *	0 - 127 0 - 127*1	
Velocity Note ON Note OFF	0 9nH v = 0 - 127*2 0 8nH v = 0 - 127	0 9nH v = 1 - 127 0 9nH v = 0, 8nH v = 0 - 127	
After Touch Key's Ch's	X X	X O	
Pitch Bender	O	O	
Control Change	0 1 5 7 11 16 17 18 19 64	O O O O O O O O O O	Bank select Modulation Portamento Time Volume Expression FX1 knob FX2 knob MIX FADER ASSIGNABLE fader Hold 1

65						
66						
67						
71						
72						
73						
74						
76						
77						
78						
Program Change	: True #		O * * * * * * * * * * * * * * *	O 0 - 127		Portamento On/Off Sostenuto Soft pedal Filter Resonance Release Time Attack Time Filter Cutoff Vibrato rate Vibrato depth Vibrato delay
System Exclusive			X	O *3		
System Common	: Song Pos : Song Sel : Tune		X X X	X X X		
System Real Time	: Clock : Commands		X O	X O		
Aux Messages	: All sound off : Reset all controller : Local ON/OFF : All notes OFF : Active Sense : Reset		X O X O X X	O O O O X X		
Remarks			#1 : Depends on tone #2 : 1 to 127 when not MIDI Control Mode #3 : Corresponds to Master Volume, Master Pan, Master Fine Tuning, Master Coarse Tuning, Reverb Time			

Mode 1 : OMNI ON, POLY
Mode 3 : OMNI OFF, POLY

Mode 2 : OMNI ON, MONO
Mode 4 : OMNI OFF, MONO

O : Yes
X : No

CASIO®

CASIO COMPUTER CO., LTD.
6-2, Hon-machi 1-chome
Shibuya-ku, Tokyo 151-8543, Japan

MA1503-A



XWPD1-E-2A

© 2015 CASIO COMPUTER CO., LTD.