



ES

Privia

PX-400R

USER'S GUIDE GUÍA DEL USUARIO

Please keep all information for future reference.
Guarde toda información para tener como referencia futura.

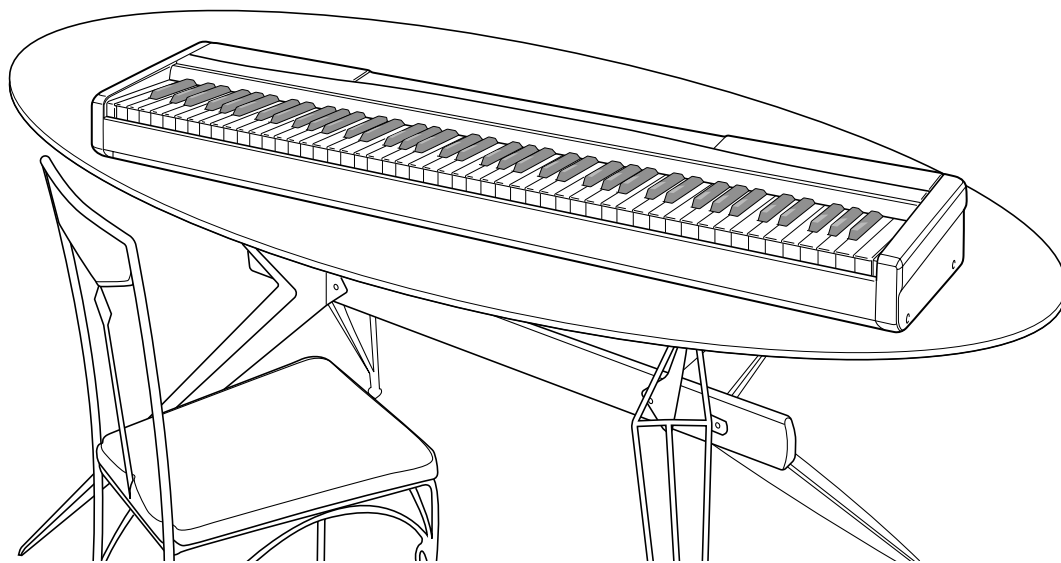

Safety Precautions

Before trying to use the digital piano, be sure to read the separate "Safety Precautions".

Precauciones de seguridad

Antes de intentar usar el piano digital, asegúrese de leer las "Precauciones de seguridad" separadas.

PX400R-ES-1

CASIO®

TO REDUCE THE RISK OF FIRE OR ELECTRIC SHOCK, REFER SERVICING TO QUALIFIED SERVICE PERSONNEL.

IMPORTANT SAFETY INSTRUCTIONS

1. Read these instructions.
 2. Keep these instructions.
 3. Heed all warnings.
 4. Follow all instructions.
 5. Do not use this apparatus near water.
 6. Clean only with dry cloth.
 7. Do not block any ventilation openings. Install in accordance with the manufacturer's instructions.
 8. Do not install near any heat sources such as radiators, heat registers, stoves, or other apparatus (including amplifiers) that produce heat.
 9. Do not defeat the safety purpose of the polarized or grounding-type plug. A polarized plug has two blades with one wider than the other. A grounding type plug has two blades and a third grounding prong. The wide blade or the third prong are provided for your safety. If the provided plug does not fit into your outlet, consult an electrician for replacement of the obsolete outlet.
 10. Protect the power cord from being walked on or pinched particularly at plugs, convenience receptacles, and the point where they exit from the apparatus.
 11. Only use attachments/accessories specified by the manufacturer.
 12. Use only with the cart, stand, tripod, bracket, or table specified by the manufacturer, or sold with the apparatus. When a cart is used, use caution when moving the cart/apparatus combination to avoid injury from tip-over.
- 
13. Unplug this apparatus during lightning storms or when unused for long periods of time.
 14. Refer all servicing to qualified service personnel. Servicing is required when the apparatus has been damaged in any way, such as power-supply cord or plug is damaged, liquid has been spilled or objects have fallen into the apparatus, the apparatus has been exposed to rain or moisture, does not operate normally, or has been dropped.

The apparatus shall not be exposed to dripping or splashing and that no objects filled with liquids, such as vases, shall be placed on the apparatus.

NOTICE

This equipment has been tested and found to comply with the limits for a Class B digital device, pursuant to Part 15 of the FCC Rules. These limits are designed to provide reasonable protection against harmful interference in a residential installation. This equipment generates, uses and can radiate radio frequency energy and, if not installed and used in accordance with the instructions, may cause harmful interference to radio communications. However, there is no guarantee that interference will not occur in a particular installation. If this equipment does cause harmful interference to radio or television reception, which can be determined by turning the equipment off and on, the user is encouraged to try to correct the interference by one or more of the following measures:

- Reorient or relocate the receiving antenna.
- Increase the separation between the equipment and receiver.
- Connect the equipment into an outlet on a circuit different from that to which the receiver is connected.
- Consult the dealer or an experienced radio/TV technician for help.

FCC WARNING

Changes or modifications not expressly approved by the party responsible for compliance could void the user's authority to operate the equipment.

Important!

Please note the following important information before using this product.

- Before using the AD-12 Adaptor to power the unit, be sure to check the AC Adaptor for any damage first. Carefully check the power cord for breakage, cuts, exposed wire and other serious damage. Never let children use an AC adaptor that is seriously damaged.
- The product is not intended for children under 3 years.
- Use only CASIO AD-12 adaptor.
- The AC adaptor is not a toy.
- Be sure to disconnect the AC adaptor before cleaning the product.



CASIO Europe GmbH
Bornbarch 10, 22848 Norderstedt, Germany

419A-E-002A

Contents

General Guide E-2

Attachment of the Score Stand E-2

Power Supply E-4

Using the AC Adaptor E-4

Connections E-5

Connecting Headphones E-5

Connecting to a PEDAL Jack E-5

Connecting an audio or musical instrument amplifier ... E-5

Selecting and Using Built-in Tones E-6

Tone Type E-6

Selecting a Tone E-6

Using Tone Effects E-7

Layering Two Tones E-7

Splitting the Keyboard between Two Tones E-8

Using Layer and Split Together E-8

Using the Piano's Pedals E-9

Using the PITCH BEND Wheel E-9

Using the Metronome E-9

Playing a Rhythm E-10

Playing a Rhythm E-10

Using Auto Accompaniment E-11

Adjusting the Volume of Accompaniment, Tune,
and Memory Card Playback E-13

Using Auto Harmonize E-13

Using One-Touch Preset E-14

Using Registration Memory E-15

What is registration memory? E-15

Playing Back Built-in Tunes E-17

Playing Back a Piano Group Tune E-17

Playing Back a Song Group Tune E-17

Adjusting Playback Tempo E-17

Pausing Playback E-18

Skipping Back through a Tune E-18

Skipping Forward through a Tune E-18

Looping a Musical Phrase E-18

Changing the Melody Tone of a Tune E-18

Playing All of the Built-in Tunes E-19

Playing Tunes You Download from the Internet E-19

Playing Music Data from a Memory Card E-19

Practicing a Built-in Tune E-19

Using a Microphone for Sing Along E-20

Using Transpose E-21

Recording Your Keyboard Play E-22

Recordable Data, Parts, and Tracks E-22

Recording Your Practice (Song Recording) E-23

Recording a Performance (Free Recording) E-23

Playing Back a Free Recording E-24

Overdubbing a Free Recording E-25

Deleting a Specific Part/Track E-25

Other Settings E-26

Keyboard Touch E-26

Keyboard Tuning E-26

Layer Tone Volume E-26

Pitch Bend Range E-26

Soft/Sostenuto Pedal Setting E-26

Display Contrast E-26

Using MIDI E-27

Connecting to a Computer E-27

USB Mode and MIDI mode E-28

Expanding the Number of Built-in Tunes E-28

Using a Memory Card E-29

Using a Memory Card E-29

Saving Files to a Memory Card E-30

Loading a File from a Memory E-31

Renaming a Memory Card File E-32

Deleting a Memory Card File E-32

Formatting a Memory Card E-33

Supported Input Characters E-33

Memory Card Error Messages E-34

Troubleshooting E-35

Specifications E-37

Appendix A-1

Tone List A-1

Rhythm List A-3

Song List A-4

Drum Assignment List A-5

Fingered Chord Chart A-6

Operational Precautions A-7

MIDI Implementation Chart

Company and product names used in this manual may be registered trademarks of others.

General Guide

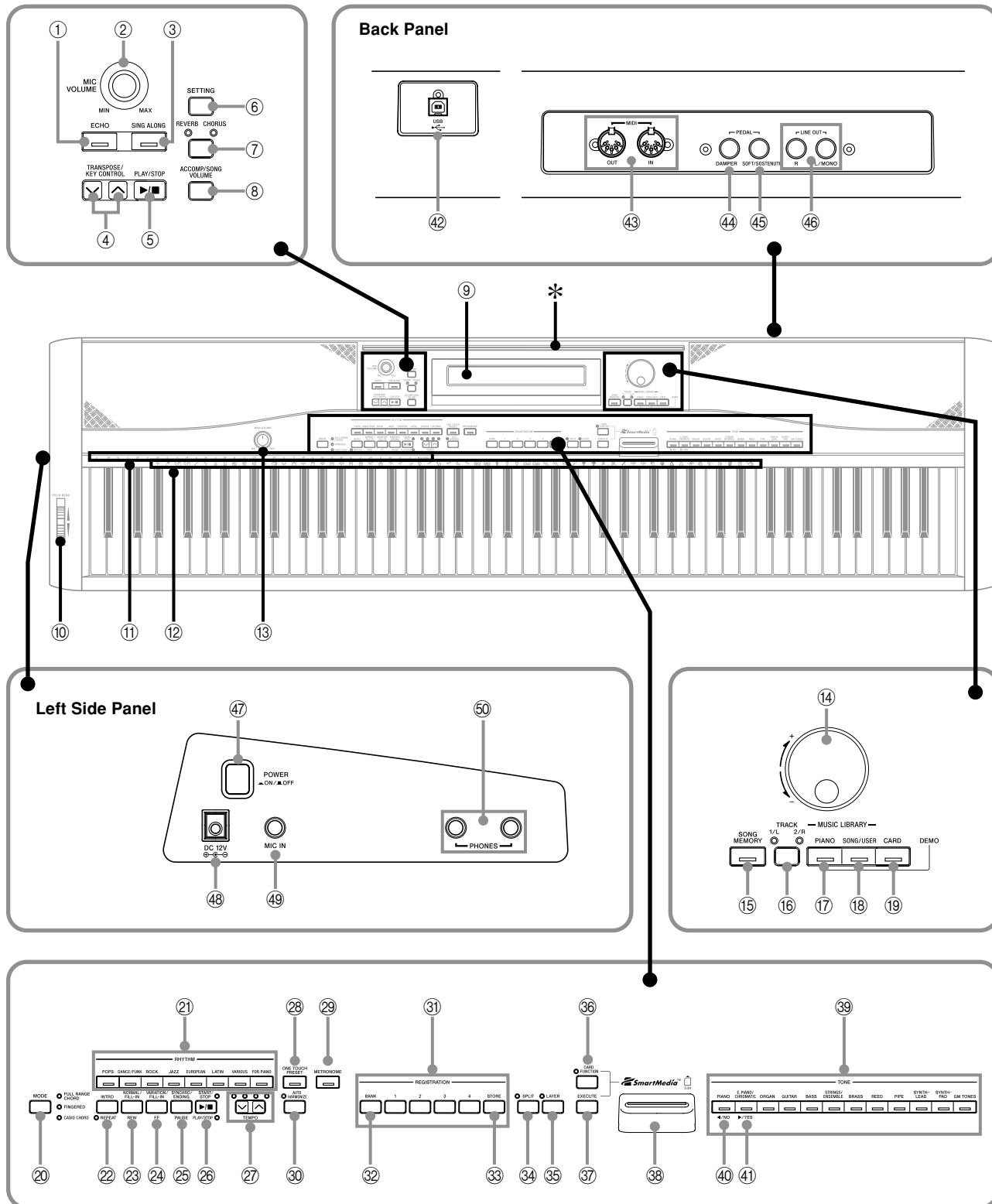

*Attachment of the Score Stand

Insert the score stand into the slot at the top of the digital piano as shown in the illustration.

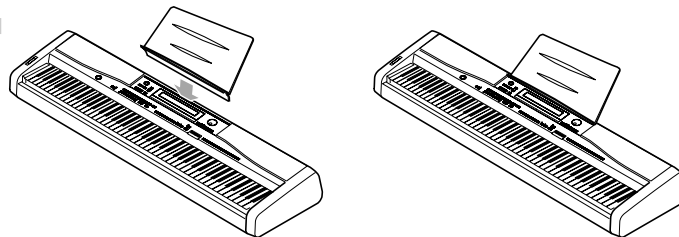



General Guide

- ① ECHO button
- ② MIC VOLUME knob
- ③ SING ALONG button
- ④ TRANSPOSE/KEY CONTROL buttons
- ⑤ <PLAY/STOP> button
- ⑥ SETTING button
- ⑦ REVERB CHORUS button
- ⑧ ACCOMP/SONG VOLUME button
- ⑨ Display screen
- ⑩ PITCH BEND wheel
- ⑪ CHORD root name
- ⑫ Percussion instrument list
- ⑬ MAIN VOLUME knob
- ⑭ Dial
- ⑮ SONG MEMORY button
- ⑯ TRACK 1/L 2/R button
- ⑰ PIANO button
- ⑱ SONG/USER button
- ⑲ CARD button
- ⑳ MODE button
- ㉑ RHYTHM buttons
- ㉒ INTRO, REPEAT button
- ㉓ NORMAL/FILL-IN, REW button
- ㉔ VARIATION/FILL-IN, FF button
- ㉕ SYNCHRO/ENDING, PAUSE button
- ㉖ START/STOP, PLAY/STOP button
- ㉗ TEMPO buttons
- ㉘ ONE TOUCH PRESET button
- ㉙ METRONOME button
- ㉚ AUTO HARMONIZE button
- ㉛ REGISTRATION buttons
- ㉜ BANK button
- ㉝ STORE button
- ㉞ SPLIT button
- ㉟ LAYER button
- ㊱ CARD FUNCTION button
- ㊲ EXECUTE button
- ㊳ Card slot
- ㊴ TONE buttons
- ㊵ [◀] cursor/NO button
- ㊶ [▶] cursor/YES button

● MUSIC LIBRARY

- ⑰ PIANO button
- ⑱ SONG/USER button

- ⑲ CARD button
- ⑳ MODE button
- ㉑ RHYTHM buttons
- ㉒ INTRO, REPEAT button
- ㉓ NORMAL/FILL-IN, REW button
- ㉔ VARIATION/FILL-IN, FF button
- ㉕ SYNCHRO/ENDING, PAUSE button
- ㉖ START/STOP, PLAY/STOP button

[Back panel]

- ㉚ USB port
- ㉛ MIDI OUT/IN terminals
- ㉜ PEDAL DAMPER jack
- ㉝ PEDAL SOFT/SOSTENUTO jack
- ㉞ LINE OUT R, L/MONO jacks

[Left side panel]

- ㉗ POWER button
- ㉘ DC 12V jack
- ㉙ MIC IN jack
- ㉚ PHONES jacks

NOTE

- Key, button, and other names are indicated in the text of this manual using bold type.
- This digital piano has two **PLAY/STOP** buttons. In this manual, the **PLAY/STOP** button that is located under the **SING ALONG** button is indicated as **<PLAY/STOP>**.
- Each chapter of this manual starts with an illustration of the digital piano's console, which shows the buttons and other controllers you need to operate.

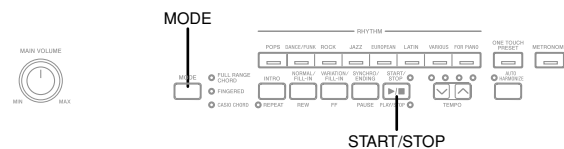

Power Supply

You can power this digital piano by plugging it into a standard household power outlet.

Be sure you turn off power and unplug the power cord from the electrical outlet whenever the digital piano is not in use.

Using the AC Adaptor

Make sure that you use only the AC adaptor specified for this digital piano.

Specified AC Adaptor: AD-12

[Left Side Panel]

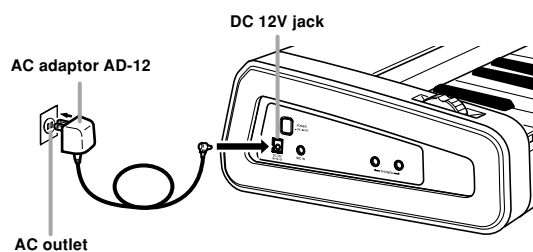

IMPORTANT!

- Make sure that the product is turned off before connecting or disconnecting the AC adaptor.
- Using the AC adaptor for a long time can cause it to become warm to touch. This is normal and does not indicate malfunction.
- Do not pull on the AC adaptor cord with excessive force while it is connected to the digital piano. Doing so can damage the AC adaptor terminal.
- When storing the AC adaptor, do not wrap the cord around the adaptor. Doing so can damage cord connections.

Memory Protection

Certain settings and memory contents are retained even when the digital piano is turned off. This means that the data and settings will still be available when you turn the digital piano back on again. This following is a list of the major settings and memory contents that are retained.

- Song Memory Data
- Registration Memory Contents
- User Songs
- Display Contrast Setting
- Music Library Song Numbers

Connections

IMPORTANT!

- Whenever connecting external equipment, first set the **MAIN VOLUME** knob of the digital piano and the volume controller of the external equipment to relatively low volume settings. You can later adjust volume to the level you want after connections are complete.

Connecting Headphones

Connect commercially available headphones to the digital piano's **PHONES** jacks. This cuts off the built-in speakers, which means you can practice even late at night without disturbing others. To protect your hearing, make sure that you do not set the volume level too high when using headphones.

[Left Side Panel]

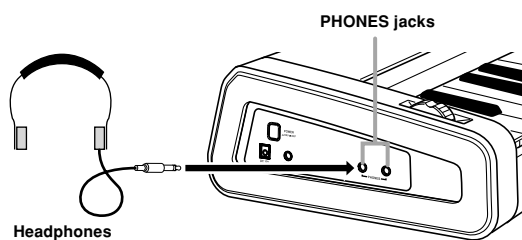

Connecting to a PEDAL Jack

Depending on the type of operation you want the pedal (SP-3) to perform, connect the pedal's cable to the digital piano's **PEDAL DAMPER** jack or **PEDAL SOFT/SOSTENUTO** jack. If you want to use both jacks at the same time, you need to purchase another optionally available pedal. See "Using the Digital Piano's Pedals" on page E-9 for information about using a pedal.

[Back Panel]

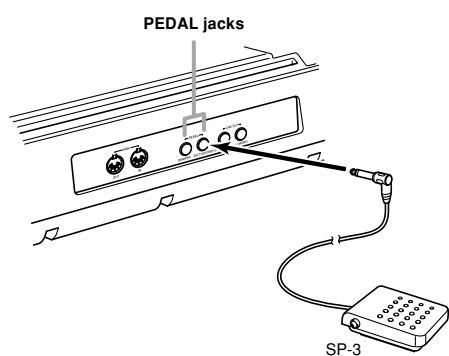

Connecting an audio or musical instrument amplifier

Connecting to an audio or musical instrument amplifier provides even clearer, more powerful sound through external speakers.

IMPORTANT!

- The digital piano automatically adjusts sound output to optimize for headphone output (when headphones are connected) or built-in speaker output (when headphones are not connected). Note that this feature also affects the sound output from the **LINE OUT R** and **L/MONO** jacks.

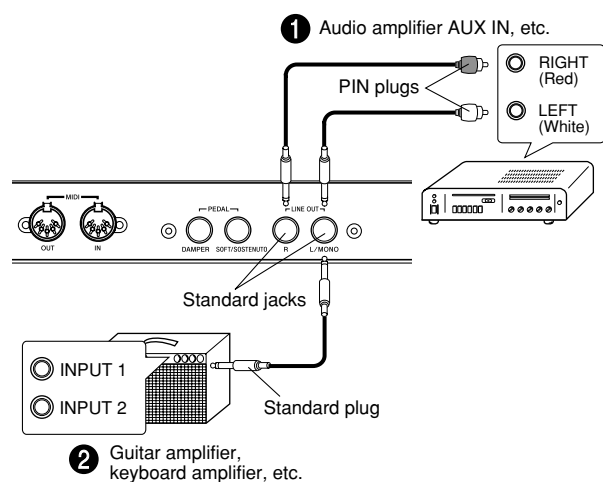

Connecting to Audio Equipment ①

Use commercially available cables to connect the external audio equipment to the digital piano's **LINE OUT** jacks as shown in Figure ①. **R** jack output is right channel sound, while **L/MONO** jack output is left channel sound. It is up to you to purchase connecting cables like the ones shown in the illustration for connection of audio equipment. Normally in this configuration you must set the audio equipment's input selector to the setting that specifies the terminal (such as **AUX IN**) to which the digital piano is connected. Use the digital piano's **MAIN VOLUME** knob to adjust the volume level.

Connecting to a Musical Instrument Amplifier ②

Use commercially available cables to connect the amplifier to the digital piano's **LINE OUT** jacks as shown in Figure ②. **R** jack output is right channel sound, while **L/MONO** jack output is left channel sound. Connecting to the **L/MONO** jack only outputs a mixture of both channels. It is up to you to purchase connecting cables like the ones shown in the illustration for connection of the amplifier. Use the digital piano's **MAIN VOLUME** knob to adjust the volume level.

Accessories and Options

Use only the accessories and options specified for this digital piano. Use of non-authorized items creates the danger of fire, electric shock, and personal injury.

Selecting and Using Built-in Tones

Tone Type

Your digital piano has the following types of tones built in.

Panel Tones	120
GM Tones	128
Drum Sets	10

- See the Tone List on page A-1 for more information.

Selecting a Tone

Panel tones are divided into 12 groups. You can select a group by pressing its **TONE** button on the digital piano control panel.

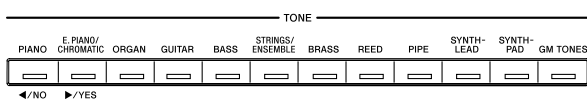

- 1 Press the **POWER** button.

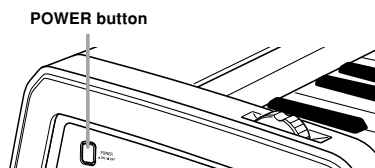

- 2 Use the **MAIN VOLUME** knob to adjust the volume level.

- Before playing, it is a good idea to set the volume to a relatively low level.

- 3 Press one of the 12 **TONE** buttons to select the tone group you want.

- For information about each tone group, see the tone list on page A-1.

Example: ORGAN

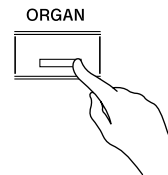

- Pressing a **TONE** button causes its indicator lamp to light.

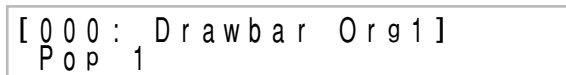

- 4 Rotate the dial to select a tone in the current selected tone group.

- Rotating the dial scrolls through the names of the available tones on the display. Display the name of the tone you want to use.

Example: Jazz Organ

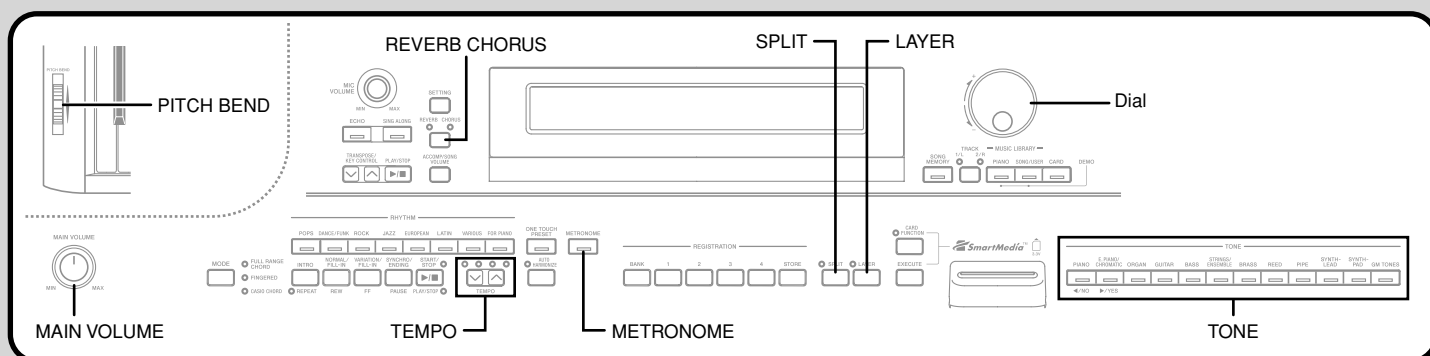
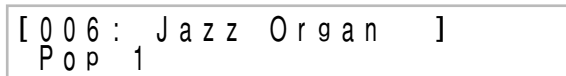

Selecting and Using Built-in Tones

Using Tone Effects

Reverb: Makes your notes resonate
Chorus: Adds more breadth to your notes

- 1 Press the **REVERB CHORUS** button to cycle through the effect settings as shown below.

- You can find out the current effect setting by looking at the REVERB and CHORUS indicator lamps.

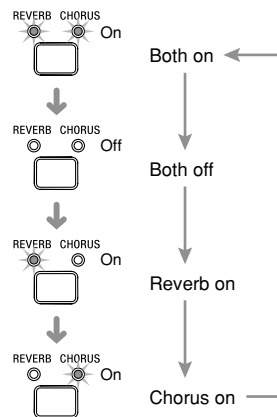

- 2 After turning on the effect you want, use the dial to select the effect type you want.

- Note that you need to select an effect type with the dial within a few seconds after turning on an effect. If you don't, the display will exit the setting screen.

Effect List

Reverb	Room 1
	Room 2
	Hall 1
	Hall 2
Chorus	Chorus 1
	Chorus 2
	Chorus 3
	Chorus 4

Reverb Type:
[Room 1]

Chorus Type:
[Chorus 1]

Layering Two Tones

Use the following procedure to layer two tones, so they sound at the same time.

- 1 Use the procedure under "Selecting a Tone" on page E-6 to select the main tone.

Example: To select Grand Piano, press the **PIANO** button, and then rotate the dial until "Grand Piano" is displayed as the tone name.

- 2 Press the **LAYER** button.

- This causes the LAYER indicator lamp to light.

- 3 Select the layered tone.

Example: To select Strings

[000 : S t r i n g s]
P o p s 1

- This will cause the indicator lamp of the layered tone (the second one you selected) to light.
- Now you can play using your layered tones.

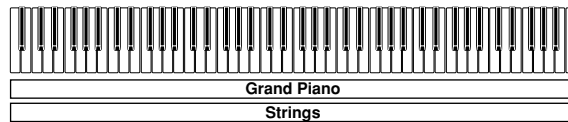

- 4 After you are finished using the layered tones, press the **LAYER** button again to unlayer them.

Adjusting the Volume of the Layered Tone

You can independently adjust the volume of the layered tone (the second one you select). See page E-26 for more information.

Selecting and Using Built-in Tones

Splitting the Keyboard between Two Tones

You can assign different tones to keys on the left side and the right side of the keyboard.

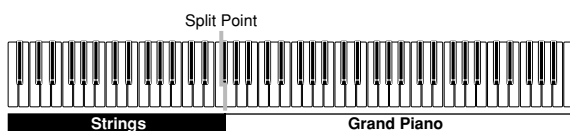

- 1 Use the procedure under “Selecting a Tone” to select the tone you want to assign to the right side of the keyboard.

Example: To select Grand Piano, press the **PIANO** button, and then rotate the dial until “Grand Piano” is displayed as the tone name.

- 2 Press the **SPLIT** button.
 - This causes the SPLIT indicator lamp to light.

- 3 Select the tone you want to assign to the left side of the keyboard.

Example: Strings

 - Now you can play using the two tones.

- 4 After you are finished using the split keyboard, press the **SPLIT** button again to unsplit it.
 - This causes the SPLIT indicator lamp to go out.

To specify the keyboard split point

- 1 While holding down the **SPLIT** button, press the keyboard key where you want the left limit of the high range (right) tone to be.

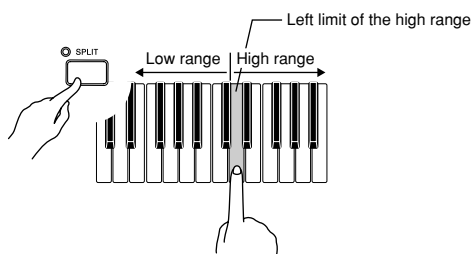

- A note does not sound when you press a keyboard key at this time.

Split Point:
F # 3

NOTE

- The split point is the boundary between the Auto Accompaniment area (pages E-11, E-12) and the melody area of the keyboard. You can change the location of the split point, which also changes the sizes of the keyboard areas.

Using Layer and Split Together

You can use the following procedure to layer two tones on the left side of the keyboard (left main tone + left layered tone), and two other tones on the right side (right main tone + right layered tone).

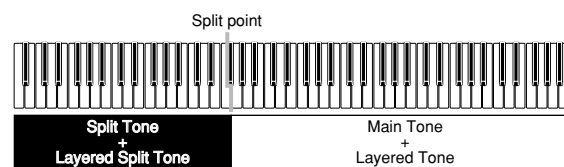

- 1 Use the procedure under “Selecting a Tone” to select the right main tone.
- 2 Use the procedure under “Splitting the Keyboard between Two Tones” to select the left main tone.

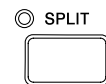

- 3 Press the **SPLIT** button to temporarily turn off split (SPLIT indicator lamp unlit).

- 4 Use the procedure under “Layering Two Tones” to select the left layered tone.

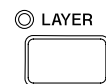

- 5 Press the **LAYER** and **SPLIT** buttons as required so the indicators of both buttons are lit.

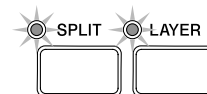

- 6 Use the procedure under “Layering Two Tones” to select the right layered tone.

- 7 Use the procedure under “To specify the keyboard split point” to specify the split point.

- 8 Now you can play using your layered tones and split keyboard.

- After you are finished using layer and split, press the **LAYER** button to unlayer it and the **SPLIT** button to unsplit it.



Selecting and Using Built-in Tones

Using the Digital Piano's Pedals

The digital piano is equipped with two pedal jacks, one for a damper pedal and one for a soft/sostenuto pedal. You can use the procedure below to specify the type of operation that should be performed by the pedal connected to the **PEDAL SOFT/SOSTENUTO** jack.

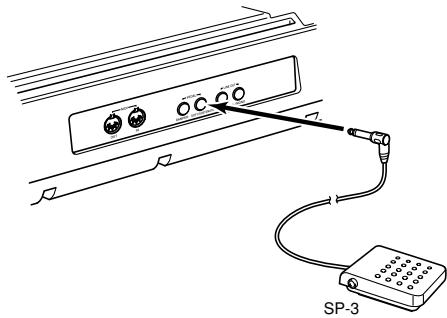

Pedal Types

● Damper Pedal

Pressing the pedal connected to the **DAMPER** jack while playing notes causes the notes to sustain until you release the pedal.

● Soft Pedal

While the **SOFT** pedal is depressed, the volume of notes played on the keyboard is reduced slightly, producing a softer sound. Only notes that are played after the pedal is depressed are affected, while previously played notes are not.

● Sostenuto Pedal

Like the **DAMPER** pedal, pressing the **SOSTENUTO** pedal causes notes to continue to sustain until you release the pedal. The difference is the timing when the effect is applied. With the sostenuto pedal you play the notes and then depress the pedal before releasing the keyboard keys. Only the notes whose keyboard keys are depressed when the sostenuto pedal is pressed are affected.

Selecting the PEDAL SOFT/SOSTENUTO jack Pedal Function

The initial power on setting of the **PEDAL SOFT/SOSTENUTO** jack is for soft pedal operation. See "Other Settings" on page E-26 for information about changing to sostenuto pedal operation.

Using the PITCH BEND Wheel

Rotating the **PITCH BEND** wheel causes the pitch of notes to bend. This lets you add realistic effects to saxophone, electric guitar, and other tones.

- 1 While playing a note on the keyboard, rotate the **PITCH BEND** wheel on the left of the keyboard upwards or downwards.
 - Releasing the **PITCH BEND** wheel will cause the pitch to return to its normal setting automatically.

Using the Metronome

- 1 Press the **METRONOME** button.
 - This starts the metronome.
- 2 Rotate the dial to select the number of beats per measure.
 - Note that you need to select the number of beats per measure with the dial within a few seconds after turning on the metronome. If you don't, the display will exit the setting screen.

Metronome Beat :
[0]

- You can select a value in the range of 2 through 6. With each setting, a chime sounds as the first beat of each measure, and the remaining beats sound as clicks. Specifying 0 as the setting plays a straight click, without any chime. This setting lets you practice with a steady beat.

- 3 Use the **TEMPO** buttons to adjust the tempo.

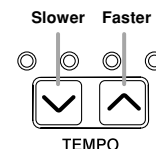

NOTE

- You can also use the dial to change the tempo setting while the current setting is indicated by a value in brackets ([]) on the display.
Example: [T:120]
- The value indicates the number of beats per minutes.
- To return the tempo to its initial default setting, press the **TEMPO** ^ and v buttons at the same time.

- 4 To stop the metronome, press the **METRONOME** button again.

Playing a Rhythm

Playing a Rhythm

You can select from among 120 built-in rhythms. See the Rhythm List on page A-3 for more information.

NOTE

- FOR PIANO group rhythms 10 through 19 consist of chord accompaniments only, without any drums or other percussion instruments. These rhythms do not sound unless CASIO CHORD, FINGERED, or FULL RANGE CHORD is selected as the accompaniment mode. With such rhythms, make sure that CASIO CHORD, FINGERED, or FULL RANGE CHORD is selected before you try playing chords.
- Note that there are two different patterns for each rhythm, named “normal” and “variation”. Buttons are available for selecting either the normal pattern or variation pattern.

Rhythms are divided into 8 groups. You can select a group by pressing its **RHYTHM** button on the digital piano control panel.

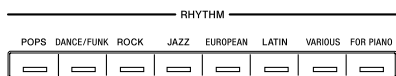

- 1 Press one of the eight **RHYTHM** buttons to select the rhythm group you want.

- For a complete list of the rhythms available in each group, see the Rhythm List on page A-3.

Example: JAZZ



- This causes the indicator lamp of the button to light.

Grand Piano
[00: Big Band 1]

- 2 Rotate the dial to select a rhythm in the current selected rhythm group.

- Rotating the dial scrolls through the names of the available rhythms on the display. Display the name of the rhythm you want to use.

Example: Swing

Grand Piano
[03: Swing]

- 3 Press the **START/STOP** button to start play of the selected rhythm's normal pattern.

- 4 If you want to change to the variation rhythm pattern, press the **VARIATION/FILL-IN** button.

- To return to the normal rhythm pattern, press the **NORMAL/FILL-IN** button.

- 5 To stop the rhythm, press the **START/STOP** button again.

NOTE

- You can also start rhythm play by pressing the **NORMAL/FILL-IN** button (plays the normal pattern) or **VARIATION/FILL-IN** button (plays the variation pattern).

To adjust the tempo of rhythm play

- 1 Use the **TEMPO** buttons to adjust the tempo of rhythm play.

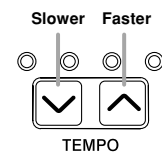

NOTE

- You can also use the dial to change the tempo setting while the current setting is indicated by a value in brackets ([]) on the display.
Example: [T:120]
- The value indicates the number of beats per minutes.
- To return the selected rhythm to its standard tempo setting, press the **TEMPO** ^ and v buttons at the same time.

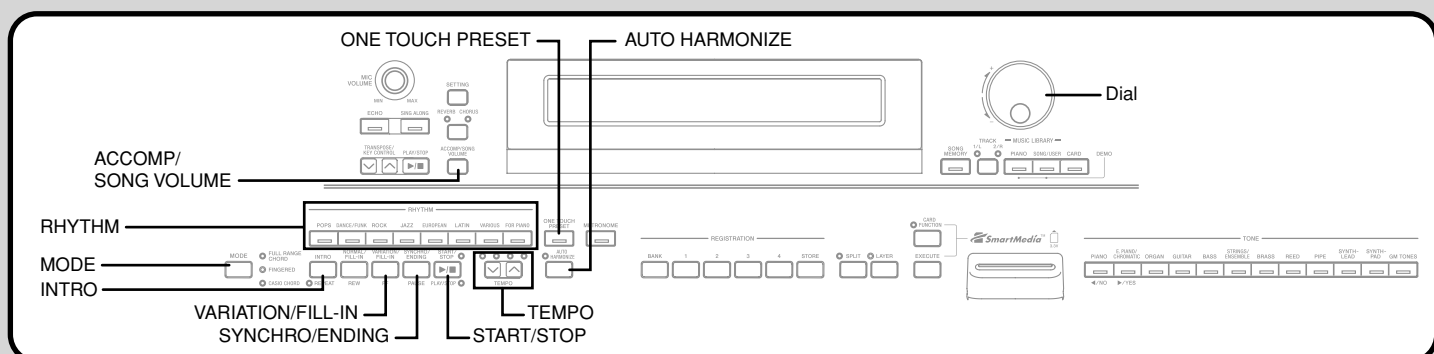

Using Auto Accompaniment

With Auto Accompaniment, the digital piano automatically plays rhythm, bass, and chord parts in accordance with chords you select using simplified keyboard fingerings, or chords you play. Auto Accompaniment makes it feel like you have your own private backup group with you all the time.

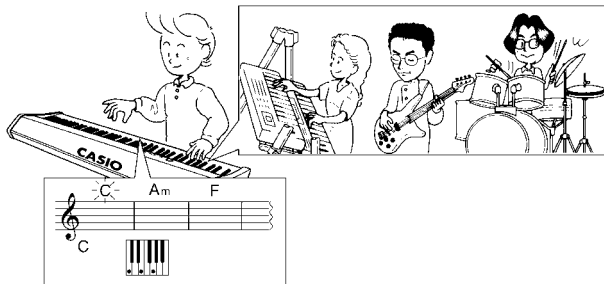

Using the MODE Button

You can use the **MODE** button to select the accompaniment mode you want to use. You can also use it to turn off Auto Accompaniment. Each press of the **MODE** button cycles through accompaniment modes in the sequence shown below.

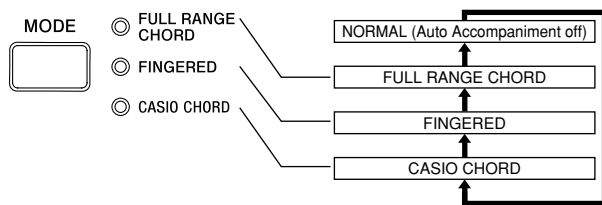

- In the **NORMAL** mode (no indicator lamp lit), only rhythm accompaniment plays.
- The **FULL RANGE CHORD**, **FINGERED**, and **CASIO CHORD** modes all play Auto Accompaniment patterns. See page E-11 for details about each of these different modes.

To play with Auto Accompaniment

Getting Ready

- Use the procedures under “Playing a Rhythm” to select the rhythm you want to use and adjust the tempo.

- 1 Use the **MODE** button to select **CASIO CHORD**, **FINGERED**, or **FULL RANGE CHORD** as the accompaniment mode.
 - Here we will select the **CASIO CHORD** mode.
 - See page E-11 for information about selecting the accompaniment mode.

- 2 Press the **SYNCHRO/ENDING** button.
 - This configures the digital piano so rhythm and chord accompaniment will start automatically when you press any keys within the accompaniment keyboard range.

- 3 Press the **INTRO** button.

- 4 Use a **CASIO CHORD** fingering to play the first chord within the accompaniment keyboard range.
 - See “How to Play Chords” on this page for information about how to finger chords with the different chord modes.
 - Playing a chord will cause the intro pattern for the selected rhythm to play, followed by the Auto Accompaniment rhythm and chord pattern.

- 5 Use **CASIO CHORD** fingerings to play other chords.
 - You can insert a fill-in pattern while an Auto Accompaniment is playing by pressing the **NORMAL/FILL-IN** button. A fill-in helps to change the mood of the Auto Accompaniment pattern.
 - If you want to change to the variation rhythm pattern, press the **VARIATION/FILL-IN** button. To return to the normal rhythm pattern, press the **NORMAL/FILL-IN** button.

- 6 To stop Auto Accompaniment play, press the **SYNCHRO/ENDING** button.
 - This will play an ending pattern for the selected rhythm before stopping Auto Accompaniment play.

NOTE

- You can start or stop auto accompaniment play without an intro or ending pattern by pressing the **START/STOP** button in steps 3 and 6.

How to Play Chords

The way you finger chords depends on the current chord mode.

■ NORMAL

In this mode, Auto Accompaniment is turned off, so you can play chords as you would normally do on a piano keyboard.

■ CASIO CHORD

Even if you do not know how to play chords normally, this mode lets you play four different types of chords using simplified fingerings in the accompaniment area of the keyboard. The following shows where the accompaniment area is located, and explains how to finger chords in the **CASIO CHORD** mode.

CASIO CHORD Mode Keyboard



IMPORTANT!

- In the **CASIO CHORD** mode, the keys in the accompaniment area of the keyboard operate as “chord switches” only. You cannot use the keys in this area to play notes.

Playing a Rhythm

Chord Type	Example
Major Chords Pressing a single accompaniment area key in the CASIO CHORD mode will play the major chord whose name is marked above the key. All of the accompaniment area keys that are marked with the same chord name play exactly the same chord.	C (C major)
Minor Chords To play a minor chord, press the accompaniment area key that corresponds to the major chord, while also pressing one other accompaniment area key to the right.	Cm (C minor)
Seventh Chords To play a seventh chord, press the accompaniment area key that corresponds to the major chord, while also pressing two other accompaniment area keys to the right.	C7 (C 7th)
Minor Seventh Chords To play a minor seventh chord, press the accompaniment area key that corresponds to the major chord, while also pressing three other accompaniment area keys to the right.	Cm7 (C minor 7th)

NOTE

- When playing a minor, seventh, or minor seventh chord, it makes no difference whether the additional keys you press are black or white.

FINGERED

In the FINGERED mode, you play standard chord fingerings in the accompaniment area to play chords. To finger a C chord, for example, you would press the C-E-G keys.

FINGERED Mode Keyboard



IMPORTANT!

- In the FINGERED mode, the keys in the accompaniment area of the keyboard operate as "chord switches" only. You cannot use the keys in this area to play notes.

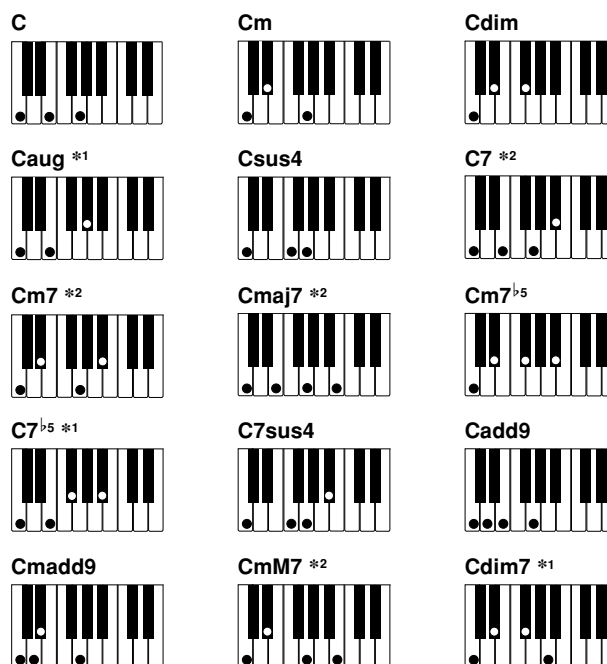

NOTE

- See the "Fingered Chord Chart" on page A-6 for information about fingering chords with other roots in the accompaniment area.

*1: Inverted fingerings are not supported for these chords. The lowest note fingered is used as the root. See the **NOTE** below for more information about inverted chords.

*2: For these chords, the same chord is specified even if the G fifth is not fingered.

NOTE

- Except for the chords whose names have *1 after them in the above examples, you can also use inverted fingerings for chords. This means, for example, that you could use the fingering E-G-C or G-C-E instead of C-E-G for C major.
- Except for the chords whose names have *2 after them in the above examples, you need to press all of the indicated keys in order to finger a chord. Failure to include even a single note may produce a chord that is different from the one you want.

■ FULL RANGE CHORD

The FULL RANGE CHORD mode lets you play a total of 38 different types of chords (the same chords available in the FINGERED mode plus 23 more). FULL RANGE CHORD recognizes the pressing of three or more keyboard keys anywhere on the keyboard as a chord fingering. Anything else (pressing one or two keys, or playing any group of notes that does not form a chord fingering that is recognized by the keyboard) is treated as melody notes.

FULL RANGE CHORD Mode Keyboard

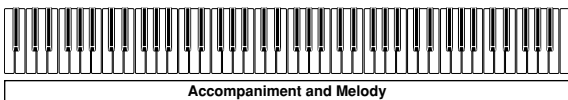

Recognized Chords

Pattern Type	Number of Chord Variations
FINGERED	The 15 chord patterns shown under "FINGERED" on page E-12.
Standard Fingerings	<p>23 standard chord fingerings. The following are examples of the 23 chords available with C as the bass note.</p> <p>C₆ • Cm₆ • C₆₉</p> <p>$\frac{D^b}{C}$ • $\frac{D}{C}$ • $\frac{E}{C}$ • $\frac{F}{C}$ • $\frac{G}{C}$ • $\frac{A^b}{C}$ • $\frac{B^b}{C}$</p> <p>$\frac{B}{C}$ • $\frac{D^bm}{C}$ • $\frac{Dm}{C}$ • $\frac{Fm}{C}$ • $\frac{Gm}{C}$ • $\frac{Am}{C}$ • $\frac{B^bm}{C}$</p> <p>$\frac{Ddim}{C}$ • $\frac{A^b7}{C}$ • $\frac{F7}{C}$ • $\frac{Fm7}{C}$ • $\frac{Gm7}{C}$ • $\frac{A^badd9}{C}$</p>

Example: To play the chord C major and $\frac{C}{E}$.

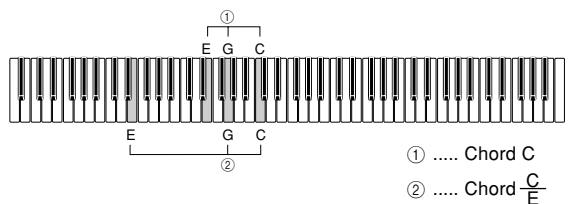

NOTE

- When there are at least six semitones between the lowest note and the next note to the right, the lowest note is assumed to be the bass note.
- Note that the digital piano's built-in tunes (Piano Group tunes and Song Group Tunes) use rhythms, accompaniments, and effects that are not available with Auto Accompaniment. Because of this, you may not be able to perform a piece exactly like a built-in tune when using Auto Accompaniment.

Adjusting the Volume of Accompaniment, Tune, and Memory Card Playback

Use the procedures below to adjust the volume of the accompaniment, built-in tune playback, and memory card tune playback. These settings are independent of the volume setting for the notes you play on the keyboard. You can specify volume levels in the range of 000 (minimum) to 127 (maximum).

- 1 Press the **ACCOMP/SONG VOLUME** button.

If the RHYTHM button indicator lamp is lit

Accomp Volume :
[1 2 7]

If the PIANO, SONG/USER, or CARD button indicator lamp is lit

Song Volume :
[1 2 7]

- 2 Use the dial to adjust the volume level.

Using Auto Harmonize

When you turn on Auto Harmonize in the FINGERED or CASIO CHORD accompaniment mode, the keyboard automatically adds one of the notes that make up the current chord to each melody note you play. This adds more depth to your melody line.

To play with Auto Harmonize

- 1 Use the **MODE** button to select the CASIO CHORD or FINGERED mode. This turns on Auto Accompaniment.
- 2 Press the **AUTO HARMONIZE** button.
 - This causes the AUTO HARMONIZE indicator lamp to light, indicating that Auto Harmonize is turned on.
- 3 Use the dial to select the Auto Harmonize type you want to use.
 - Note that you need to select the Auto Harmonize type with the dial within a few seconds after turning on the Auto Harmonize. If you don't, the display will exit the setting screen.
 - See "Auto Harmonize Types" on page E-14 for more information about Auto Harmonize types.

Auto Harmonize Type :
[Duet 1]

- 4 Start Auto Accompaniment play, and play something in the melody area of the keyboard.
 - Harmonize notes are added automatically to the melody notes you play.
- 5 To turn off Auto Harmonize, press the **AUTO HARMONIZE** button again.
 - This causes the AUTO HARMONIZE indicator lamp to go out.

Playing a Rhythm

NOTE

- Auto Harmonize is available in the FINGERED and CASIO CHORD accompaniment modes only.
- Auto Harmonize is disabled and cannot be used while playing back a tune from the Music Library or a memory card.

Auto Harmonize Types

Auto Harmonize lets you select from among the following 12 Auto Harmonize types.

Type	Effect
Duet1	Adds close (separated by 3 to 5 degrees) 1-note harmony below the melody note.
Duet2	Adds open (separated by more than 4 to 7 degrees) 1-note harmony below the melody note. Duet2 harmony is more open than Duet1.
Country	Adds country style harmony.
Octave	Adds the note from the next lower octave.
5th	Adds the fifth degree note.
3-Way Open	Adds 2-note open harmony, for a total of three notes.
3-Way Close	Adds 2-note close harmony, for a total of three notes.
Strings	Adds harmony that is optimal for strings.
4-Way Open	Adds 3-note open harmony, for a total of four notes.
4-Way Close	Adds 3-note close harmony, for a total of four notes.
Block	Adds block chord notes.
Big Band	Adds big band style harmony.

Using One-Touch Preset

With One-Touch Preset, the digital piano automatically configures optimal tone, tempo, and other settings in accordance with the rhythm pattern you select.

The following are the One-Touch Preset settings that are configured for each rhythm pattern.

- Keyboard tone and volume level
- Layer and split on/off settings
- Layer and split tone and volume settings (when layer and split are turned on)
- Tempo setting
- Effect settings
- Auto Harmonize (type, on/off settings)

To apply One-Touch Preset settings

- 1 Select the rhythm you want to use.
- 2 Use the **MODE** button to select the accompaniment mode you want to use.
- 3 Press the **ONE TOUCH PRESET** button.
 - This will automatically apply the One-Touch Preset settings in accordance with the rhythm pattern you selected, and enter synchro standby.
- 4 Play a chord within the accompaniment keyboard range.
 - When you do, the rhythm and Auto Accompaniment will start to play.
 - The notes will sound in accordance with the settings of the One-Touch Preset.

Using Registration Memory

What is registration memory?

Registration memory lets you save up to 16 (4 areas × 4 banks) digital piano setups (tone, rhythm, tempo, etc.) for instant recall whenever you need them.

Registration Memory Setup Data

The following are the settings that can be saved for each registration memory setup.

- Tone
- Rhythm
- Tempo
- Layer Setting
- Split Setting
- Split point
- Auto Harmonize Setting
- Effect setting
- MODE button setting

NOTE

- All of the registration memory banks are preset with default data.
- You cannot recall data from registration memory while playing back a tune from Music Library or a memory card.

How registration memory organizes its data

Registration memory has four banks, and each bank contains four areas. Use the **BANK** button to select a bank, and the **REGISTRATION** buttons to select an area.

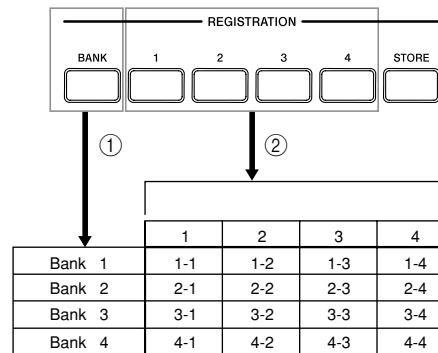

- ① Each press of the **BANK** button cycles through the bank numbers, from 1 to 4.
- ② Pressing a **REGISTRATION** button (1 to 4) selects the corresponding area in the currently selected bank.

NOTE

- Storing a new setup to a registration memory area replaces the setup that was previously stored there.
- You can save registration memory setup data to a memory card, if you want. See "Using a Memory Card" on page E-29 for more information.

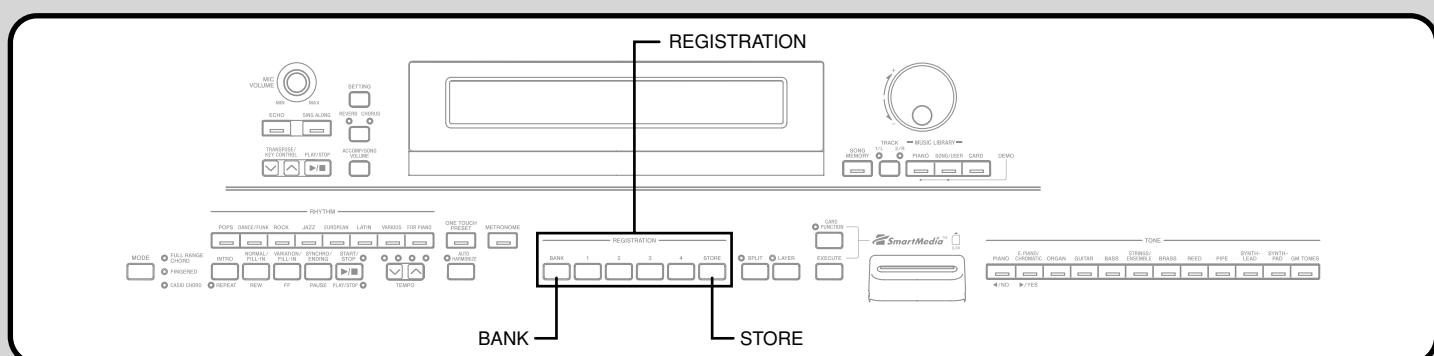

419A-E-017B

Using Registration Memory

To store a setup in registration memory

- 1 On the digital piano, configure the tone, rhythm, and other settings you want to save as your setup.
 - See "Registration Memory Setup Data" (page E-15) for more information.
- 2 Use the **BANK** button to select the registration memory bank where you want to save the setup.
 - This causes the number of the selected bank to appear on the display for about five seconds. If you do not perform the following step within that time, the bank selection screen will disappear.

Example: Bank 1 selected

Bank
1

WARNING

- The following step will replace the setup currently in the area you select with the new setup. Make sure you do not need the current setup before performing the next step.

- 3 While holding down the **STORE** button, press the **REGISTRATION** button (1 to 4) that corresponds to the area where you want to store the setup.
 - You can also change the bank selection at this time by pressing the **BANK** button while holding down the **STORE** button.

Example: After button 2 is pressed

Store Bank Area
 1 - 2

- 4 Release the **REGISTRATION** and **STORE** buttons.

To recall a setup from registration memory

- 1 Use the **BANK** button to select the registration memory bank that contains the setup you want to recall.
 - This causes the number of the selected bank to appear on the display for about five seconds. If you do not perform the following step within that time, the bank selection screen will disappear.
- 2 Press the **REGISTRATION** button (1 to 4) for the area that contains setup you want to recall.
 - This displays the number of the area you selected along with the message "Recall". After that, the tone or rhythm screen reappears.

Bank
1

Recall Bank Area
 1 - 2

NOTE

- If you press a **REGISTRATION** button without selecting a bank first, the digital piano will recall the setup from the applicable area in the bank you previously last selected.

Registration memory contents are retained even when you turn off digital piano power (page E-4, A-7).

Playing Back Built-in Tunes

Your digital piano comes with a total of 80 tunes built in. You can play back built-in tunes for your own listening pleasure, or you can use them for practice and even sing-along. Built-in tunes are divided between the two groups described below.

- **Piano Group:** 50 tunes
The tunes in this group are piano tunes.
- **Song Group:** 30 tunes
The tunes in this group are Auto Accompaniment tunes. You can connect a microphone to the digital piano and use the sing along mode to sing along with the built-in tunes.

In addition to the built-in tunes, you can also sing along with tunes you download over the Internet, and SMF data tunes (page E-19) on memory cards.

Playing Back a Piano Group Tune

Page A-4 shows a Piano Group List, which lists all of the tunes included in the Piano Group.

Getting Ready

- Use the **ACCOMP/SONG VOLUME** button (page E-13) to adjust the volume level.

- 1 Press the **PIANO** button to select the Piano Group.
 - This causes the PIANO button indicator lamp to light.

NOTE

- Pressing the **PIANO** button automatically turns off layer and split.

- 2 Rotate the dial to select the tune you want.
Example: 46 Amazing Grace

```
Grand Piano          T=064
[ 46: Amazing Grace ]
```

- 3 Press the **PLAY/STOP** button to start playback of the tune.
- 4 When you want to stop playback, press the **PLAY/STOP** button again.
 - The same tune plays repeatedly until you stop it.

Playing Back a Song Group Tune

Page A-4 shows a Song Group List, which lists all of the tunes included in the Song Group.

Getting Ready

- Use the **ACCOMP/SONG VOLUME** button (page E-13) to adjust the volume level.

- 1 Press the **SONG/USER** button to enter the song mode.
 - This causes the SONG/USER button indicator lamp to light.
- 2 Rotate the dial to select the tune you want.
Example: 28 Sakura Sakura

```
GM Syn-Voice          T=074
[ 28: Sakura Sakura ]
```

- 3 Press the **PLAY/STOP** button to start Auto Accompaniment.
- 4 When you want to stop Auto Accompaniment play, press the **PLAY/STOP** button again.
 - The same tune plays repeatedly until you stop it.

Adjusting Playback Tempo

- 1 Use the **TEMPO** buttons to adjust the tempo.

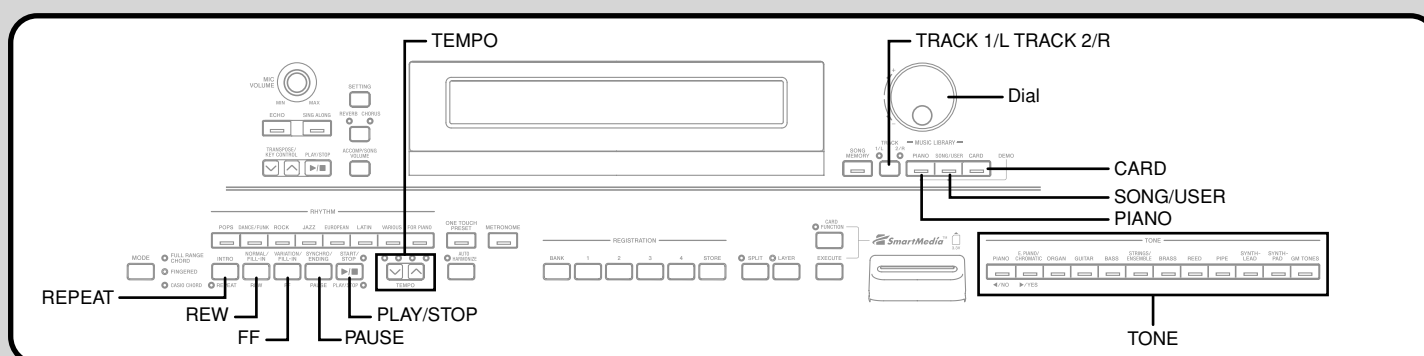
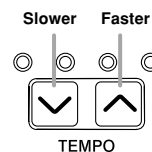

419A-E-019B

Playing Back Built-in Tunes

NOTE

- You can also use the dial to change the tempo setting while the current setting is indicated by a value in brackets ([]) on the display.
Example: [T:120]
- The value indicates the number of beats per minutes.
- To return the tempo to its initial default setting, press the **TEMPO** \wedge and \vee buttons at the same time.
- At their initial default tempo setting, some Piano Group tunes may change tempo part way through. After you change the tempo setting for such a tune, playback will proceed at the tempo you selected, from the beginning of the tune to the end.

Pausing Playback

- While a tune is playing, press the **PAUSE** button.
 - This pauses playback.
- Press the **PAUSE** button again to restart playback from the location where it was paused.

Skipping Back through a Tune

- While playback is in progress, hold down the **REW** button.
 - This skips back through the tune measure-by-measure.
 - The measure number and beat number appear on the display while you are skipping back.

0 0 6 : 1
Measure number Beat number

- When you reach the point you want, release the **REW** button to resume playback.

NOTE

- Depending on what is being played when you press the **REW** button, the skip back operation may not start right away when you press it.

Skipping Forward through a Tune

- While playback is in progress, hold down the **FF** button.
 - This skips forward through the tune measure-by-measure.
 - The measure number and beat number appear on the display while you are skipping forward.

0 0 3 : 1
Measure number Beat number

- When you reach the point you want, release the **FF** button to resume playback.

Looping a Musical Phrase

You can select one or more measures and “loop” them, which means that they play again and again until you stop playback.

- While the tune is playing, press the **REPEAT** button while the measure you want the phrase to start from is playing.
 - This causes the REPEAT indicator lamp to flash.
- When playback reaches the measure you want to specify as the end of the loop, press the **REPEAT** button again.
 - This starts repeat play of the loop.
 - To cancel repeat play of a loop, press the **REPEAT** button again so its indicator goes out.

Changing the Melody Tone of a Tune

You can select any one of the digital piano’s 248 built-in tones as the melody tone of a built-in tune. You can even change the melody tone setting while playback is in progress.

- Press a **TONE** button.
- Use the dial to select the tone you want.

NOTE

- You can return a tune to its preset default tone by selecting the tune again.



Playing Back Built-in Tunes

Playing All of the Built-in Tunes

You can use the following procedure to play through all of the digital piano's 80 built-in tunes in tune number sequence.

- 1 Press the **PIANO** button and **SONG/USER** button at the same time.
 - This starts playback of the built-in tunes in tune number sequence, starting from Piano Group tune number 00.
- 2 To stop playback, press the **PLAY/STOP** button.

NOTE

- During playback of all the built-in tunes, you can use the dial to select a specific song for playback.

Playing Tunes You Download from the Internet

You can save music data for up to 10 tunes you download from the Internet to the digital piano's user song area (Song Group tunes 30 through 39). Once you store a song in digital piano memory, you can play it back using the same procedure as the one for playing built-in tunes.

- 1 Press the **SONG/USER** button.
 - This causes the SONG/USER button indicator lamp to light.
- 2 Rotate the dial to select the tune you want.
- 3 Press the **PLAY/STOP** button.
 - This starts playback of the tune you selected.
 - Press the **PLAY/STOP** button again to stop playback.

Playing Music Data from a Memory Card

You can play back SMF* data from a memory card loaded in the digital piano's card slot for your listening enjoyment or sing along fun. For more information about using memory cards, see "Using a Memory Card" on page E-29.

- * Standard MIDI File
SMF is a file format for storing MIDI data and other data used by a MIDI device to play back music. When music data is saved to a card in SMF format by a computer running commercially available music software, the data can be read and played by this digital piano.

IMPORTANT!

- Before performing the procedure below, read "Using a Memory Card" on page E-29, and make sure you observe all precautions concerning use of the card slot and memory cards.

Getting Ready

- Insert the memory card that contains the SMF data you want to play into the digital piano's card slot.

- 1 Press the **CARD** button.
 - This causes CARD button indicator lamp to light.
- 2 Rotate the dial to select the tune you want.
- 3 Press the **PLAY/STOP** button.
 - This starts playback of the tune you selected.
 - To stop playback, press the **PLAY/STOP** button again.

NOTE

- If there is not enough memory available to perform the above operation, pressing the **PLAY/STOP** button will cause a data delete confirmation message to appear (Memory Full: Data Delete? No/Yes). Pressing the **YES** button will delete all of the data currently stored in the user area (No.30 to 39) of the Song Group. If you do not want to delete the user area data, press the **NO** button instead.

Practicing a Built-in Tune

You can turn off the left hand part or right hand part of a built-in tune, user song, or SMF data* and play along on the digital piano.

- * With SMF data, the left-hand part is assigned to Channel 3, while the right-hand part is assigned to Channel 4.

Getting Ready

- Select the tune you want to practice and adjust the tempo. If you are playing a tune for the first time, a slow tempo is probably best.

- 1 Use the **TRACK** button to turn the parts on or off.
 - Each press of the **TRACK** button toggles its indicator lamp on (part turned on) and off (part turned off).
 - To practice the left hand part, the TRACK 1/L indicator lamp should be off.
 - To practice the right hand part, the TRACK 2/R indicator lamp should be off.

NOTE

- With Song Group tunes (30 through 39), you cannot turn off the left hand part.

- 2 Press the **PLAY/STOP** button.
 - This starts playback of the tune, without the part you selected in step 1.
- 3 Play the missing part on the digital piano.
- 4 To stop playback, press the **PLAY/STOP** button again.

Using a Microphone for Sing Along

You can connect a microphone to the digital piano to sing along with built-in tunes, or with playback of SMF data from a memory card.

Using the Microphone Jack

You can connect a commercially available microphone to the digital piano's microphone jack. Before connecting a microphone, set the **MIC VOLUME** knob to a relatively low setting. Next, adjust the volume to the desired level after connecting the microphone.

- 1 Set the **MIC VOLUME** knob to the "MIN" setting.
- 2 Use the microphone's switch to turn it on.
- 3 Use the **MIC VOLUME** knob to adjust the microphone volume level.

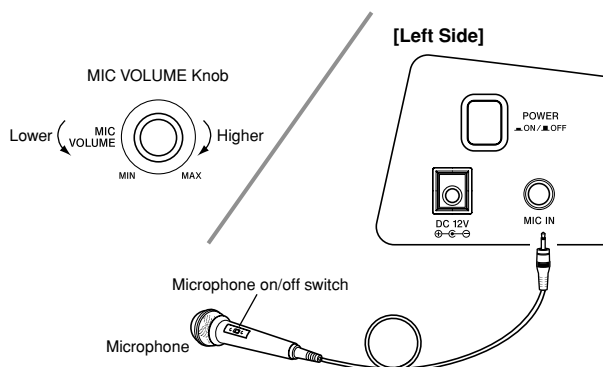

IMPORTANT!

- You may get static noise in the microphone output if there is an external device connected to the digital piano's MIDI terminal.
- Be sure to unplug the microphone from the digital piano when you are not using it.

Recommended Microphone Type

Dynamic microphone (standard plug)

Feedback

Any of the following conditions can result in feedback, which causes a howling sound to be produced through the speakers.

- Cupping the head of the microphone with your hands.
- Positioning the microphone too close to the speakers.

If howling occurs, hold the microphone by the barrel (not the head) and move it away from the speakers.

Noise

Fluorescent lighting near the microphone can cause noise. If this happens, move the microphone away from the fluorescent lighting causing the noise.

To sing along with playback

Getting Ready

- Adjust the **MAIN VOLUME** (page E-6), **ACCOMP/SONG VOLUME** (page E-13), and **MIC VOLUME** (page E-20) to appropriate levels.

- 1 Find the tune you want in the Song Group List, and note its number.
 - See page A-4 for the Song Group List.
- 2 Press the **SING ALONG** button to enter the sing along mode.
 - This causes the SING ALONG button indicator lamp to light.
- 3 Select the sing along source.
 - <Built-in Tune>
Press the **SONG/USER** button so its indicator lamp is lit. This is the sing along song mode.
 - <Memory Card Tune>
Press the **CARD** button so its indicator lamp is lit. This is the sing along card mode.
- 4 Rotate the dial to select the tune you want.

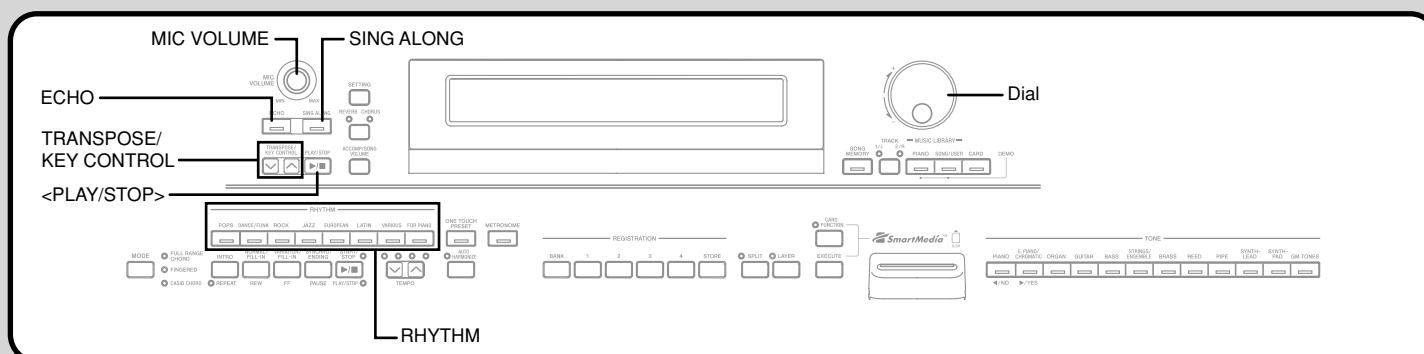

Using a Microphone for Sing Along

- 5 Press the **<PLAY/STOP>** button to start playback.
- If the song you selected includes lyric data, the lyrics appear on the digital piano's display.
 - Use the microphone to sing along with the playback.
 - When you pressing the **SING ALONG** button and enter the Sing Along mode, the digital piano will automatically reduce the volume of the melody part of the tune. It will also change the tone setting to make sing along easier.

- 6 You can use the **TRANPOSE/KEY CONTROL** \wedge and \vee buttons to change the key of the song.

To do this:	Press this button:
Raises the key by one semitone.	\wedge
Lower the key by one semitone.	\vee

Key Control:
[- 1 2]

- 7 When you want to stop playback, press the **<PLAY/STOP>** button again.
- The same tune plays repeatedly until you stop it.
 - To exit the Sing Along mode, press the **SING ALONG** button so its indicator lamp goes out.

NOTE

- To return the tune to its default key "00", press both of the **TRANPOSE/KEY CONTROL** buttons (\wedge and \vee) at the same time in step 6 of the above procedure.

Using Microphone Echo

You can turn microphone echo on or off as required.

- 1 Press the **ECHO** button.
- This turns on microphone echo and causes the **ECHO** button indicator lamp to light.
- 2 To turn off microphone echo, press the **ECHO** button again.

Using Transpose

The transpose feature lets you transpose the overall pitch of the keyboard in semitone steps. This means you can adjust digital piano tuning to make it easier to sing to a particular tune.

- 1 Press the **RHYTHM** button to enter the rhythm mode.
- Note that you cannot use the transpose feature in the song mode and piano mode.

- 2 Use the **TRANPOSE/KEY CONTROL** \wedge and \vee buttons to change the key of the digital piano.

To do this:	Press this button:
Raises the pitch by one semitone.	\wedge
Lower the pitch by one semitone.	\vee

Example: When the digital piano pitch is raised by five semitones

Transpose:
[+ 0 5]

- You can also change the setting by rotating the dial.

NOTE

- The transpose setting range is -12 (1 octave down) to +12 (1 octave up).
- The power on default setting is "00".
- The transpose screen disappears from the display automatically if you do not perform any button operation for about five seconds.
- The transpose setting is also reflected in memory tune and Auto Accompaniment play.
- To return the digital piano to its default pitch "00", press both of the **TRANPOSE/KEY CONTROL** buttons (\wedge and \vee) at the same time in step 2 of the above procedure.

Recording Your Keyboard Play

You can record your practice sessions while playing along with a Song Memory tune (Song Recording), or you can record your keyboard play along with the Auto Accompaniment you are using (Free Recording).

Recordable Data, Parts, and Tracks

The type of data that is recorded into Song Memory depends on whether you are performing song recording or free recording.

Song Recording: Right-hand part or left-hand part
Free Recording: One tune, consisting of two tracks as shown in the illustration below

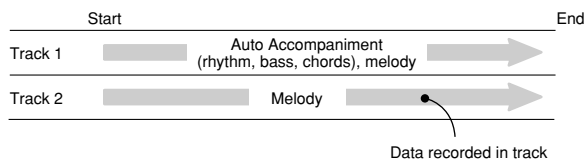

- Since each track is independent of the other, you can edit a recording by re-recording only one of the tracks.

Using the SONG MEMORY Button

Each press of the SONG MEMORY button cycles through the song memory options in the sequence shown below.

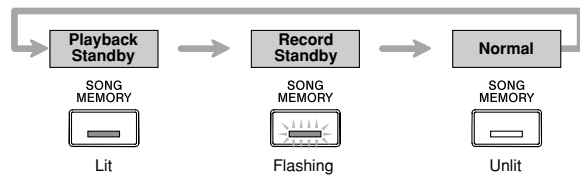

Selecting Parts and Tracks

You can determine the current status of each part/track by checking indicator lamps above the TRACK button.

• During Playback Standby

Each press of the TRACK button toggles Left-hand part/Track 1 and Right-hand part/Track 2 between playback and non-playback.

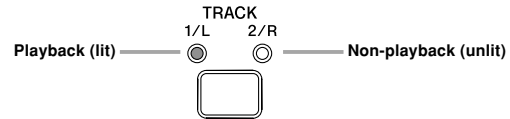

• During Record Standby

Each press of the TRACK button toggles Left-hand part/Track 1 and Right-hand part/Track 2 between record standby and playback.

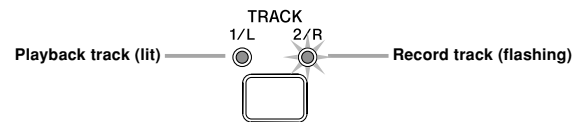

Song Memory Capacity

Song Memory can hold a total of approximately 5,300 notes, which can be divided between a song recording and a free recording. Note that you can use all 5,300 notes for a single recording, if you want. If you do, you will not be able to store a second recording.

- Recording will stop automatically if Song Memory becomes full. If you are using Auto Accompaniment or a rhythm, they will also stop playing at this time.

Recorded Data Storage

- Starting a new recording deletes any data that was previously recorded in memory.
- Should power fail during recording, all of the data in the track you are recording will be deleted.
- A built-in lithium battery supplies the power required to retain digital piano memory contents when power is turned off. Should the lithium battery go dead, memory contents will be lost whenever you turn off digital piano power. For more information, see "Memory Protection" on page A-7.

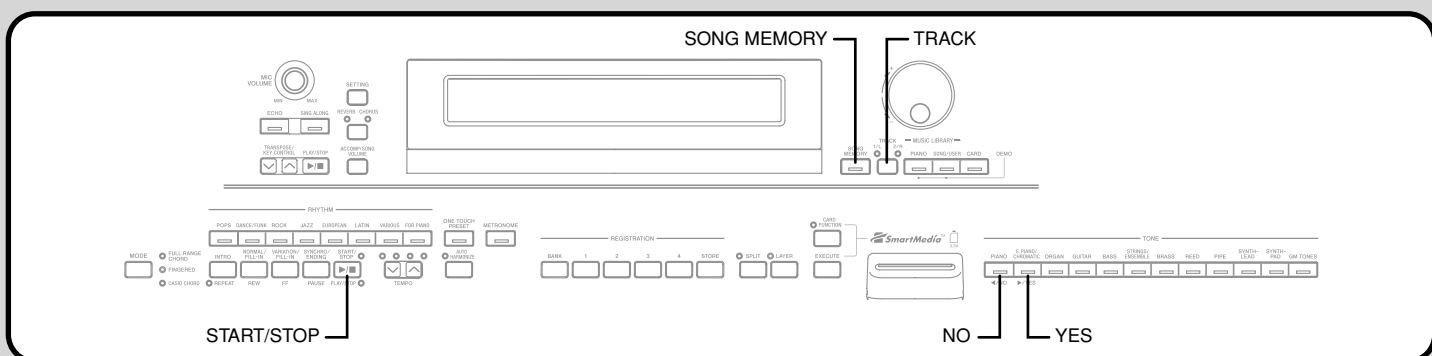

Recording Your Practice (Song Recording)

You can use the procedure below to record your play during practice with one of the digital piano's built-in tunes. You can specify which parts you want to practice, and the keyboard plays the remaining parts as accompaniment.

Getting Ready

- Press the **SONG/USER** button or **PIANO** button to select the mode that contains the tune you want to use for recording.

- 1 Press the **SONG MEMORY** button to enter record standby.
 - This causes the SONG MEMORY button indicator lamp to flash.
- 2 Select the tune you want to use for recording.
- 3 Use the **TRACK** button to select the part you want to record.
- 4 Configure the following settings as required.
 - Tone (page E-6)
 - Tempo (page E-17)
- 5 Press the **START/STOP** button to start recording.
- 6 Play the required notes on the keyboard.
- 7 To stop recording, press the **START/STOP** button again.
 - This will stop the recording operation.
 - * **If you want to immediately hear what you recorded, press the START/STOP button again.**

Song Recording Data

In addition to your keyboard play and chord accompaniment, the following data is also stored by a song recording operation.

- Tone setting
- Tempo setting
- Tune name
- Recording part
- Pedal operations
- Layer and split settings
- Reverb and chorus settings
- PITCH BEND wheel operations

Playing Back a Song Recording

Getting Ready

- Press the **SONG MEMORY** button to enter playback standby.

- 1 Press the **START/STOP** button.
 - This starts playback of Song Memory contents.
 - Use the **TEMPO** buttons to adjust the tempo.
- 2 To stop playback, press the **START/STOP** button again.

Recording a Performance (Free Recording)

Use this procedure when you want to record accompaniments and keyboard play in real time.

Getting Ready

- Press the **RHYTHM** button to enter the rhythm mode.

- 1 Press the **SONG MEMORY** button to enter record standby.
 - This causes the SONG MEMORY button indicator lamp to flash.
- 2 Use the **TRACK** button to select Track 1.

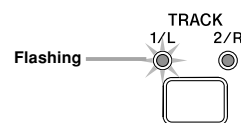

- 3 Configure the following settings as required.
 - Tone (page E-6)
 - Rhythm (page E-10)
 - Accompaniment mode (page E-11)
 - * **Use a slower tempo if you feel you might have trouble playing properly at a faster tempo (page E-17).**
- 4 Press the **START/STOP** button.
 - This starts recording.
- 5 Play the required notes on the keyboard.
 - Any chords you play on the keyboard are recorded, along with their Auto Accompaniment patterns. Melody notes you play are also recorded.
 - Any pedal operations you perform while playing are also recorded.
- 6 To stop recording, press the **START/STOP** button again.
 - * **If you make a mistake, you need to go back and re-record from step 1.**
 - * **If you want to immediately hear what you recorded, press the START/STOP button again.**

NOTE

- Recording a performance to a track that already contains data causes the existing data to be replaced by your new performance.

Recording Your Keyboard Play

Free Recording Track 1 Data

In addition to notes played on the keyboard and chord accompaniments, the following data is also stored in Track 1 during performance recording.

- Tone number
- Rhythm number
- Rhythm controller operations
- Pedal operations
- Layer and split settings
- Split point
- Tempo setting
- Reverb and chorus settings
- Auto Harmonize setting
- Registration Memory Contents
- One Touch Preset setting
- PITCH BEND wheel operations

Track 1 Free Recording Variations

● To record without rhythm

Skip step 4 of the above procedure.

- Recording without rhythm starts as soon as you press a keyboard key.

● To start recording with synchro start

In place of step 4 of the above procedure, press the **SYNCHRO/ENDING** button.

- Now Auto Accompaniment and recording will start when you play a chord within the accompaniment keyboard range.

● To start recording with an intro using synchro start

In place of step 4 of the above procedure, press the **SYNCHRO/ENDING** button and then the **INTRO** button.

- Now Auto Accompaniment and recording will start with an intro pattern when you play a chord within the accompaniment keyboard range.

● To start Auto Accompaniment part way into a recording

In place of step 4 of the above procedure, press the **SYNCHRO/ENDING** button, and then play something within the melody range of the keyboard.

- This records the melody without any accompaniment. Auto Accompaniment will start when you play a chord within the accompaniment keyboard range.

● To insert an ending or fill-in into a recording

During recording, use the **SYNCHRO/ENDING** button, **NORMAL/FILL-IN** button and **VARIATION/FILL-IN** button.

Playing Back a Free Recording

Use the procedure below to playback what you have recorded with free recording.

Getting Ready

- Press the **RHYTHM** button to enter the rhythm mode.
- Press the **SONG MEMORY** button to enter playback standby.

1 Press the **START/STOP** button.

- This starts playback of Song Memory contents. During Song Memory playback, you can use the **TRACK** button to mute either track and listen to the contents of the other track only.
- Use the **TEMPO** buttons to adjust the tempo.

2 To stop playback, press the **START/STOP** button again.

NOTE

- During Song Memory playback, the entire range of the keyboard operates as a melody keyboard, regardless of the **MODE** button setting. You can play along with Song Memory playback, if you want. You could use layer and split (page E-7, E-8) at this time to assign multiple tones to the keyboard, if you want.
- Note that pause, skip forward, and skip back operations cannot be performed during Song Memory playback.

Recording Your Keyboard Play

Overdubbing a Free Recording

You can use the following procedure to record a melody in Track 2 that combines something else that you previously recorded in Track 1.

Getting Ready

- Press the **RHYTHM** button to enter the rhythm mode.
- Press the **SONG MEMORY** button to enter record standby.

- 1 Use **TRACK** button to select Track 2.

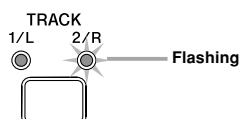

- 2 Configure the following setting as required.

- Tone number

* **Use a slower tempo if you feel you might have trouble playing properly at a faster tempo (page E-17).**

- 3 Press the **START/STOP** button.

- This starts playback from Track 1 and recording to Track 2.

- 4 Play the melody notes you want as you listen to the playback from Track 1.

- 5 To stop recording, press the **START/STOP** button again.

* **If you make a mistake, you need to go back and re-record from step 1.**

* **If you want to immediately hear what you recorded, press the **START/STOP** button again.**

NOTE

- Track 2 is a melody-only track, which means that chord accompaniment cannot be recorded there. Because of this, the entire range of the keyboard becomes a melody keyboard when recording the Track 2, regardless of the current **MODE** button setting.
- If you want to record without playback from a recorded track, enter playback standby, deselect the playback track, and then enter record standby. Note, however, that you cannot turn off rhythm and Auto Accompaniment.

Free Recording Track 2 Data

In addition to notes played on the keyboard, the following data is also recorded to Track 2.

- Tone number
- Pedal operations
- **PITCH BEND** wheel operations

Deleting a Specific Part/Track

You can use the following procedure to delete a specific part/track from a song recording or free recording.

Getting Ready

<When deleting a song recording part>

- Press the **SONG/USER** button or **PIANO** button.

<When deleting a free recording part>

- Press the **RHYTHM** button.

- 1 Press the **SONG MEMORY** button to enter record standby.

- 2 Use the **TRACK** button to select the part/track you want to delete.

- 3 Hold down the **SONG MEMORY** button until a confirmation message appears on the display.

- To cancel the delete operation, press the **NO** button.

- 4 Press the **YES** button to delete the data.

- This causes the digital piano to return to Song Memory playback standby.

NOTE

- Pressing the **SONG MEMORY** button while the part/track delete screen is on the display returns to record standby.

Song Memory contents are retained even when you turn off digital piano power (page E-4, A-7).

Other Settings

Use the procedure provided below to change the following settings.

Keyboard Touch

This setting changes the relative touch of the keyboard keys.

- off : Off
- Light : Weak (Strong sound is produced even when relatively light pressure is applied.)
- Normal : Normal
- Heavy : Strong (Normal sound is produced even when relatively strong pressure is applied.)

Touch Select :
[Normal]

Keyboard Tuning

Use this setting to raise or lower the overall pitch of the digital piano to match another instrument. The setting range is plus or minus 50 cents (100 cents = 1 semitone) from the standard pitch of A4 = 440.0Hz.

Tuning :
[- 5 0]

Layer Tone Volume

You can specify a volume value in the range of -24 to 00 to +24 for the layered tone when using the layer feature (page E-7).

Layer Balance :
[0 0]

Pitch Bend Range

This setting specifies the maximum change in a tone that can be applied using the **PITCH BEND** wheel. The setting range is 00 (no change) to 12 (12 semitones).

Pitch Bend Range :
[0 2]

Soft/Sostenuto Pedal Setting

This setting specifies whether the pedal connected to the digital piano's **PEDAL SOFT/SOSTENUTO** jack should operate as a soft pedal or a sostenuto pedal.

Pedal Assign :
[Sostenuto]

Display Contrast

Use this setting to adjust the contrast of the display screen (00 to 16).

Contrast :
[1 6]

To configure other settings

- 1 Press the **SETTING** button.
- 2 Use the [◀] and [▶] cursor buttons to display the setting screen for the parameter whose setting you want to change.
- 3 Use the dial to change the currently displayed setting.
- 4 After all the settings are the way you want, press the **SETTING** button.

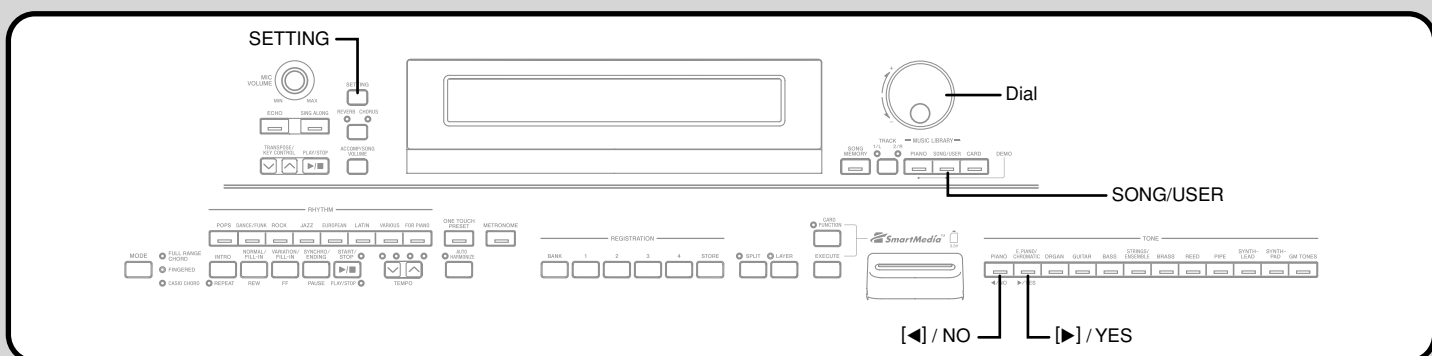



Other Settings

Using MIDI

What is MIDI?

MIDI is a standard for digital signals and connectors that allows musical instruments, computers, and other devices, regardless of manufacturer, to exchange data with each other.

MIDI Connections

Connecting your computer or other external MIDI device to the digital piano's MIDI IN/OUT terminals makes it possible for them to exchange MIDI messages and record and playback keyboard notes on the connected device.

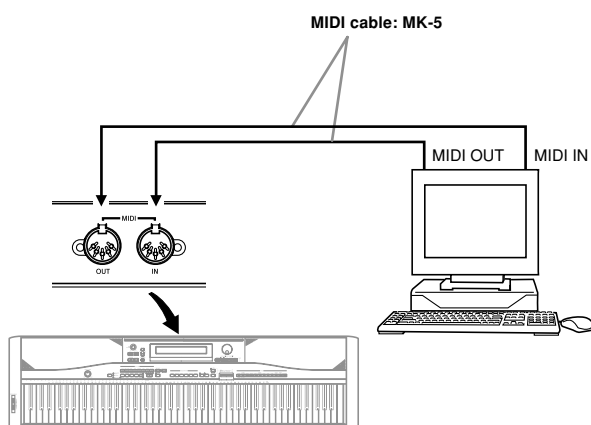

Configuring MIDI Settings

● Send Channel

Use this setting to specify one of the MIDI channels (1 through 16) as the Send Channel, which is used for sending MIDI messages to an external device.

Keyboard Channel :
[16]

● Local Control

When Local Control is turned on, pressing the keyboard's keys plays the notes using the currently selected built-in tone, and also sends the applicable MIDI messages out the MIDI OUT port. Turning off Local Control causes MIDI messages to be sent out the MIDI OUT port, but the nothing is played by the digital piano's sound source when keys are pressed. This comes in handy when you want to turn off the piano's keyboard and use its auto accompaniment feature to accompany an external sequencer or other device.

Local Control :
[Off]

● Accom MIDI Out

This setting controls whether or not MIDI messages for the digital piano's Auto Accompaniment should be sent.

Accomp Out :
[Off]

To configure MIDI settings

- 1 Press the **SETTING** button.
- 2 Use the [◀] and [▶] cursor buttons to display the screen for the MIDI setting you want to change.
- 3 Use the dial to change the currently displayed setting.
- 4 After all the settings are the way you want, press the **SETTING** button.

Connecting to a Computer

You can use the digital piano's USB Port to connect to a computer.

Using the USB Port

Note that you need to purchase a commercially available USB cable to connect to a computer using the USB port.

To connect to a computer using the USB port

- 1 On the computer to which you plan to connect, install the USB driver that on the CD-ROM that comes bundled with the digital piano.
 - See the readme.txt file on the CD-ROM for details about how to install the driver.
- 2 Use a commercially available USB cable to connect the digital piano to the computer.

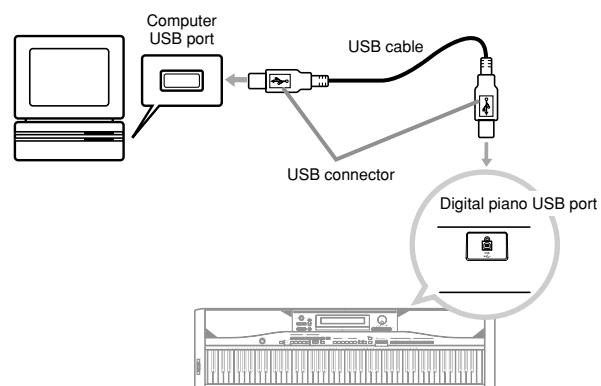

Other Settings

USB Mode and MIDI Mode

Your digital piano has two data communication modes: a USB mode and a MIDI mode.

The USB mode is used when sending and receiving data via the digital piano's USB port, while the MIDI mode is used for data send and receive via its MIDI terminals.

USB Mode/MIDI Mode Switching

The digital piano will enter the USB mode automatically whenever a connection is established between it and the USB driver running on a connected computer. Any other time (when there is no USB connection between the digital piano and a computer), the digital piano is in the MIDI mode.

USB Mode

Active Port: USB

- If you connect to a computer via the USB port before turning on power, the screen will show "USB" when you turn on power. Note that the screen also will show "USB" and the digital piano will enter the USB mode if you turn on power while there are connections to both the USB port and the MIDI terminals.
- The "USB" indicator will appear for about one second to indicate the USB mode whenever you connect to a computer via the USB port while the digital piano is turned on.

MIDI Mode

Active Port: MIDI

- If you connect another device to the digital piano's MIDI terminals (only) before turning on power, the screen will show "MIDI" when you turn on power.
- Disconnecting from the digital piano's USB port while the digital piano is turned on will cause the "MIDI" indicator to appear for about one second to indicate the MIDI mode.

Expanding the Number of Built-in Tunes

You can transfer song data for up to 10 tunes (approximately 132 kilobytes) to digital piano memory and store it as Song Group tunes number 30 through 39.

You can obtain a copy of the special CASIO conversion software by downloading it at the Web page shown below. After downloading, install the software on your computer.

CASIO MUSIC SITE

<http://music.casio.com/>

- * In addition to the software itself, the CASIO MUSIC SITE will also provide you with information about its installation and use. You can also find out about how to connect your computer and digital piano, the latest news about your digital piano and other CASIO musical instruments, and much more.

Deleting a User Song

Use the following procedure to delete a user song you have loaded to digital piano memory from your computer.

- 1 Hold down the **SONG/USER** button until a user song selection screen appears.

ML User Song Delete?
[30 : x x x x x x] x x x KB

- To exit the selection screen, press the **NO** button.
- 2 Use the dial to select the song you want to delete.
 - 3 Press the **YES** button to delete the song.
 - The display should now show 0 kilobytes.

Using a Memory Card

In addition to the digital piano's memory, you can also use a SmartMedia memory card to store digital piano data or data loaded from your computer. The following table shows the types of data you can save to a memory card.

<Savable File Types>

Type	Display Indicator	File Name Extension
Music Library tunes	M.L. Song	.CM2
Song Memory Data	MemorySong	Song Recording: .CSM Free Recording: .CSR
Registration Memory Setups	Registration	.CR3

Using a Memory Card

The digital piano has a card slot that accepts SmartMedia™ memory cards. This provides you with the means to store virtually unlimited amounts of user song and other data from digital piano memory. SmartMedia memory cards are available in capacities ranging from 8MB up to 128MB. The cost of a card varies according to its capacity. Note also that SmartMedia memory cards are available for two different voltages: 3.3V and 5V. This digital piano supports the use of 3.3V cards.

Though a SmartMedia memory card is about the size of a postage stamp, it has anywhere from eight times to 100 times the storage capacity of a floppy diskette, and it provides very high-speed access. SmartMedia memory cards are available from household appliance stores, computer shops, etc.

* SmartMedia™ is a trademark of Toshiba Corporation.

NOTE

- The term "memory card" in this manual refers to the SmartMedia memory card.

Memory Cards

IMPORTANT!

- Be sure to use only a 3.3V SmartMedia memory card that has one of the following capacities.
8MB, 16MB, 32MB, 64MB, 128MB

WARNING

- Use of 5V SmartMedia memory cards is not supported.
- Note that you will not be able to store data to, delete data from, or rename files on a memory card that has a write protect sticker in the write protect area.

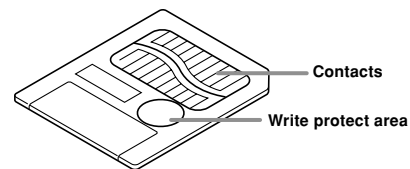

Memory Card and Card Slot Handling Precautions

IMPORTANT!

- When using a memory card, make sure you observe all of the precautions in the instructions that come with it.
- Avoid using a memory card in the following types of areas. Such conditions can corrupt data stored on the memory card.
 - Areas subjected to high temperature, high humidity, and corrosive gas
 - Areas subjected to strong electrostatic charge and digital noise
- Never touch the contacts of a memory card when loading it or removing it from the digital piano.
- Never remove the memory card from the card slot or turn off the digital piano while any data access operation (save, read, delete) is in progress. Doing so can corrupt the data on the memory card and damage the card slot.
- Never insert anything besides a memory card into the card slot. Doing so creates the risk of malfunction.
- Inserting a memory card that carries an electrostatic charge into the card slot can cause malfunction of the digital piano. If this happens, turn digital piano power off and then back on again.
- A memory card can become quite warm after very long use in the card slot. This is normal and does not indicate malfunction.
- A memory card has a limited service life. If you start to experience problems with storing, reading, or deleting data from a memory card you have been using for a long time, it may mean that the card has reached the end of its service life. When this happens, you need to purchase a new card.

Note that CASIO COMPUTER CO., LTD. shall not be held liable for any loss of data stored on a memory card.

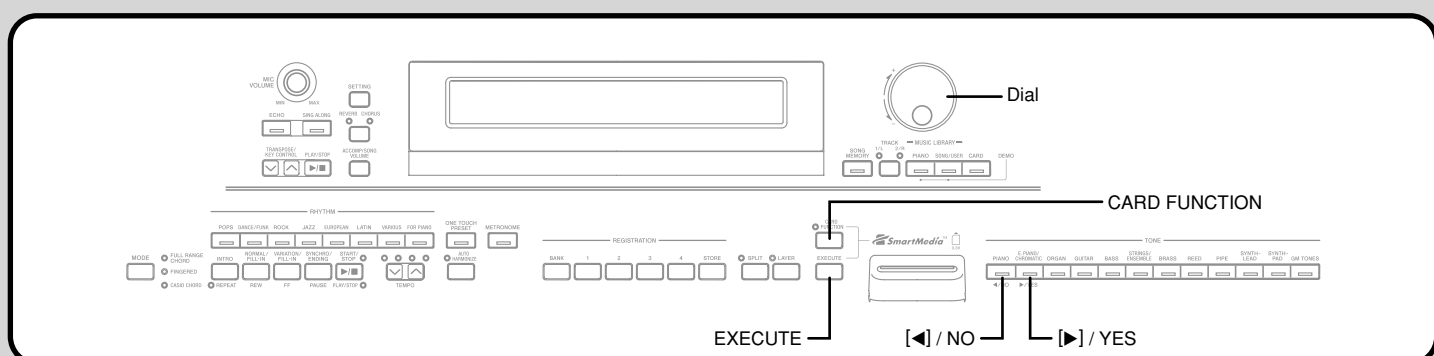

419A-E-031A

Using a Memory Card

Loading a Memory Card into the Card Slot

With the label side of the memory card facing downwards, carefully insert it into the card slot. Carefully slide the memory card straight into the slot, as far as it will go.

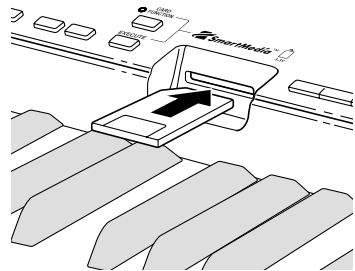

NOTE

- When inserting a SmartMedia card into the card slot, make sure you carefully orient the card correctly so it slides correctly straight into the slot.

Removing a Memory Card from the Card Slot

After making sure that the memory card is not being accessed*, pull it out of the card slot.

- * The memory card is being accessed when the **CARD** button or **CARD FUNCTION** indicator lamp is lit. Make sure that both of these indicator lamps are not lit.

IMPORTANT!

- Never remove the memory card from the card slot or turn off the digital piano while any data access operation (save, read, delete) is in progress. Doing so can corrupt the data on the memory card and damage the card slot.

Saving Files to a Memory Card

See "Savable File Types" on page E-29 for information about the type of data you can save.

Getting Ready

- Insert a properly formatted memory card into the digital piano's card slot. Make sure that the sticker is removed from the card's write area, which enables writing.

NOTE

- Depending on the type and the amount of data involved, a memory card data save or load operation can take anywhere from a few minutes to more than 10 minutes to complete. The message "Please Wait" will remain on the display to indicate that a data save or load operation is being performed.

IMPORTANT!

- Never try to perform any operation while "Please Wait" is displayed. Performing any operation can cause digital piano's built in memory data or the memory card data to be deleted, or damage data and make it impossible to read.

To save a file to a memory card

- Press the **CARD FUNCTION** button.
 - This causes the indicator lamp above the button to light.
- Use the dial to display the "Save" screen.
- Press the **[▶]** cursor button to advance to the file type selection screen.
- Use the dial to select the file type.
- Press the **[▶]** cursor button to advance to the next screen.
- Use the dial to select the file you want to save.

To save this type of file:	Select this:
Music Library playback tune	User song number/name
Song Memory data	Song number (Song 1 or Song 2)
Registration memory setup	Bank number

- After selecting a file, press the **[▶]** cursor button to advance to the next screen.
- Input the file name you want to use.
 - Use the dial to scroll through letters at the current cursor location. For details about the characters you can input, see "Supported Input Characters" on page E-33.
 - Use the **[◀]** and **[▶]** cursor buttons to move the cursor left and right.
- After inputting the file name, press the **EXECUTE** button.
 - This will display a confirmation message asking whether you really want to save the data. If the memory card already contains a file with the same name, a confirmation message appears asking if you want to overwrite the existing file with a new one.
- To save the data, press the **YES** button.
 - The message "Please Wait" will remain on the display while the save operation is being performed. Never try to perform any other operation on the digital piano while the card is being accessed. The screen in step 2 will reappear after the save operation is complete.
 - If you do not want to continue with the save operation, press the **NO** button. This will return to the screen in step 8.
- After you are finished saving the data, press the **CARD FUNCTION** button so its indicator lamp goes out.

Loading a File from a Memory

Use the procedure below to load data from a memory card into the digital piano memory.

IMPORTANT!

- Before you can use a SmartMedia card with this digital piano, you need to perform the procedure below to format it. After formatting the card, transfer SMF data from your computer to the card.
- Formatting a SmartMedia card with this digital piano automatically creates a folder named "CASIO_MD" on the card. When transferring SMF data from your computer to the card for use by the digital piano, be sure to store it in the "CASIO_MD" folder.

Getting Ready

- Insert the SmartMedia card that contains the data you want to recall into the digital piano's card slot.

NOTE

- Depending on the type and the amount of data involved, a memory card data save or load operation can take anywhere from a few minutes to more than 10 minutes to complete. The message "Please Wait" will remain on the display to indicate that a data save or load operation is being performed.

IMPORTANT!

- Never try to perform any operation while "Please Wait" is displayed. Performing any operation can cause digital piano's built in memory data or the memory card data to be deleted, or damage data and make it impossible to read.

- 8 Use the dial to select the destination of the file you are loading.

To load this type of file:	Select this destination:
Music Library playback tune	User song number/name
Song Memory data	Song number (Song 1 or Song 2)
Registration memory setup	Bank number

- 9 After selecting the destination, press the **EXECUTE** button.

- This will display a confirmation message asking whether you really want to load the data.

- 10 Press the **YES** button to load the data.

- The message "Please Wait" will remain on the display while the load operation is being performed. Never try to perform any other operation on the digital piano while the card is being accessed. The screen in step 2 will reappear after the load operation is complete.
- If you do not want to continue with the load operation, press the **NO** button. This will return to the screen in step 8.

- 11 After you are finished loading the data, press the **CARD FUNCTION** button so its indicator lamp goes out.

To load file data from a memory card

- 1 Press the **CARD FUNCTION** button.
 - This causes the indicator lamp above the button to light.
- 2 Use the dial to display the "Load" screen.
- 3 Press the [▶] cursor button to advance to the file type selection screen.
- 4 Use the dial to select the type of file you want to load.
- 5 Press the [▶] cursor button to display the file name selection screen.
- 6 Use the dial to select the name of the file you want to load.
- 7 Press the [▶] cursor button to advance to the next screen.

Using a Memory Card

Renaming a Memory Card File

You can use the procedure below to change the name of a file that you previously saved to a memory card.

Getting Ready

- Insert the memory card that contains the file you want to rename into the card slot. Make sure that the sticker is removed from the card's write protect area, which enables writing.

To rename a file on a memory card

- 1 Press the **CARD FUNCTION** button.
 - This causes the indicator lamp above the button to light.
- 2 Use the dial to display the "Rename" screen.
- 3 Press the [▶] cursor button to advance to the file type selection screen.
- 4 Use the dial to select the type of the file you want to rename.
- 5 Press the [▶] cursor button to advance to the file name selection screen.
- 6 Use the dial to select the name of the file you want to rename.
- 7 Press the [▶] cursor button to advance to the file name input screen.
 - Use the dial to scroll through letters at the current cursor location. For details about the characters you can input, see "Supported Input Characters" on page E-33.
 - Use the [◀] and [▶] cursor buttons to move the cursor left and right.
- 8 After inputting the file name, press the **EXECUTE** button.
 - This will display a confirmation message asking whether you really want to change the name.
- 9 Press the **YES** button to change the file name.
 - The message "Please Wait" will remain on the display while the rename operation is being performed. Never try to perform any other operation on the digital piano while the card is being accessed. The screen in step 2 will reappear after the rename operation is complete.
 - If you do not want to continue with the rename operation, press the **NO** button. This will return to the screen in step 7.
- 10 After you are finished renaming the file, press the **CARD FUNCTION** button so its indicator lamp goes out.

Deleting a Memory Card File

Use the procedure below to delete a file from a memory card.

IMPORTANT!

- Note that the file delete operation cannot be undone. Make sure that you no longer need data before you delete it.

Getting Ready

- Insert the memory card that contains the file you want to delete into the digital piano's card slot. Make sure that the sticker is removed from the card's write protect area, which enables writing.

To delete a file from a memory card

- 1 Press the **CARD FUNCTION** button.
 - This causes the indicator lamp above the button to light.
- 2 Use the dial to display the "Delete" screen.
- 3 Press the [▶] cursor button to advance to the file type selection screen.
- 4 Use the dial to select the type of the file you want to delete.
- 5 Press the [▶] cursor button to advance to the file name selection screen.
- 6 Use the dial to select the name of the file you want to delete.
- 7 After selecting the file to be deleted, press the **EXECUTE** button.
 - This will display a confirmation message asking whether you really want to delete the file.
- 8 Press the **YES** button to delete the file.
 - The message "Please Wait" will remain on the display while the delete operation is being performed. Never try to perform any other operation on the digital piano while the card is being accessed. The screen in step 2 will reappear after the delete operation is complete.
 - If you do not want to continue with the delete operation, press the **NO** button. This will return to the screen in step 5.
- 9 After you are finished deleting the file, press the **CARD FUNCTION** button so its indicator lamp goes out.

Using a Memory Card

Formatting a Memory Card

Use the procedure below to format a memory card.

IMPORTANT!

- Note that formatting a memory card that already contains data causes all of that data to be deleted. Data deleted by the format operation cannot be recovered. Before performing the procedure below, check to make sure that the memory card does not contain any data you might need.

Getting Ready

- Insert the memory card you want to format into the digital piano's card slot. Make sure that the sticker is removed from the card's write protect area, which enables writing.

To format a memory card

- 1 Press the **CARD FUNCTION** button.
 - This causes the indicator lamp above the button to light.
- 2 Use the dial to display the "Format" screen.
- 3 Press the **EXECUTE** button.
 - This will display a confirmation message asking whether you really want to format the memory card.
- 4 Press the **YES** button to start formatting.
 - The message "Please Wait" will remain on the display while the format operation is being performed. Never try to perform any other operation on the digital piano while the card is being accessed. The screen in step 2 will reappear after the format operation is complete.
 - If you do not want to continue with the formatting operation, press the **NO** button. This will return to the screen in step 2.
- 5 After you are finished formatting the memory card, press the **CARD FUNCTION** button so its indicator lamp goes out.

Supported Input Characters

The following shows the characters you can input when inputting the name of a file being saved to a memory card.

0	1	2	3	4	5	6	7	8	9
A	B	C	D	E	F	G	H	I	J
K	L	M	N	O	P	Q	R	S	T
U	V	W	X	Y	Z	_			

Using a Memory Card

Memory Card Error Messages

Display Message	Cause	Action
Err Card R/W	There is something wrong with the memory card.	Use a different card.
Err CardFull	The memory card is full.	<ol style="list-style-type: none"> 1. Use a different card. 2. Delete files you no longer need from the card (page E-32).
Err No Card	<ol style="list-style-type: none"> 1. The memory card is not set correctly in the card slot. 2. There is no memory card in the card slot or the card was removed part way through a card access operation. 	<ol style="list-style-type: none"> 1. Remove the card and reinsert it correctly (page E-30). 2. Insert a card into the card slot. Never remove a card from the card slot while a card access operation is in progress.
Err FileName	<ol style="list-style-type: none"> 1. A file with the same name as the one you are trying to use already exists on the memory card. 2. You are trying to use a file name that is not allowed by MS-DOS. 	<ol style="list-style-type: none"> 1. Use a different file name (page E-32). 2. Name files using the allowable characters (page E-33).
Err ReadOnly	You are trying to use a file name that is already used for a read-only file on the memory card.	Use a different card or use a different name.
Err Format	<ol style="list-style-type: none"> 1. The format of the memory card in the card slot is not supported by this digital piano. 2. The memory card in the card slot is not formatted. 3. There is something wrong with the memory card. 	<ol style="list-style-type: none"> 1. Use a card that has the supported format (page E-29). 2. Format the card (page E-33). 3. Use a different card.
Err Mem Full	There is not enough digital piano memory available to hold the data you are trying to load.	<ol style="list-style-type: none"> 1. Delete data you no longer need from the load destination where you are trying to store it. 2. If you are loading data to Song Memory, delete song data you no longer need (page E-25).
Err Not SMF0	You are attempting to load SMF (Standard MIDI File) data that is not Format 0.	Use only Format 0 SMF data.
Err No File	You are trying to load data from a card that does not contain any data that is supported by this digital piano.	Change to a memory card that contains data saved by or supported by this digital piano.
Err Protect	You are trying to save data to a memory card that is write-protected.	<ol style="list-style-type: none"> 1. Use a different card. 2. If you want to write to the current memory card, remove it from the card slot and remove the write protect sticker (page E-29).
Err WrongDat	There is a problem with the data on the memory card or the data is corrupted.	Use different data or a different card.
Err SizeOver	The data file size is greater than 132 kilobytes.	Select a data that is 132 kilobytes in size or smaller.

Troubleshooting

Problem	Cause	Action	See Page
No sound is produced when I press a digital piano key.	<ol style="list-style-type: none"> 1. The MAIN VOLUME knob is set to "MIN". 2. Headphones are connected to the digital piano. 3. MIDI Local Control is turned off. 4. Check the current accompaniment mode setting. Normally, the accompaniment keyboard will not produce any note while CASIO CHORD or FINGERED is selected as the accompaniment mode. 	<ol style="list-style-type: none"> 1. Rotate the MAIN VOLUME knob more towards "MAX". 2. Unplug the headphones from the digital piano. 3. Turn on the Local Control setting. 4. Change the accompaniment mode setting to NORMAL. 	<p>Page E-6</p> <p>Page E-5</p> <p>Page E-27</p> <p>Page E-11</p>
The pitch of the digital piano is off.	<ol style="list-style-type: none"> 1. The digital piano's key setting is something other than "C". 2. The digital piano tuning is incorrect. 	<ol style="list-style-type: none"> 1. Change the key setting to "C", or turn digital piano power off and then back on again. 2. Adjust digital piano tuning, or turn digital piano power off and then back on again. 	<p>Page E-21</p> <p>Page E-26</p>
Demo play seems to start, but I can't hear anything.	<ol style="list-style-type: none"> 1. The MAIN VOLUME knob is set to "MIN". 2. Headphones are connected to the digital piano. 	<ol style="list-style-type: none"> 1. Rotate the MAIN VOLUME knob more towards "MAX". 2. Unplug the headphones from the digital piano. 	<p>Page E-6</p> <p>Page E-5</p>
Digital piano memory contents seem to disappear.	The lithium battery used for memory backup is dead.	Contact your nearest CASIO service center to have the lithium battery replaced.	Page A-7
When I play something on the digital piano, my connected external MIDI sound source does not sound.	<ol style="list-style-type: none"> 1. This digital piano's send channel does not match the send channel of the external MIDI sound source. 2. The volume or expression setting of the external sound source is "0". 	<ol style="list-style-type: none"> 1. Configure the digital piano and the external MIDI sound source to their send channels match. 2. Adjust the volume and expression settings of the external sound source. 	<p>Page E-27</p> <p>External sound source user's guide</p>
Auto Accompaniment does not sound.	The accompaniment volume setting is "000".	Use the ACCOMP/SONG VOLUME button to increase accompaniment volume.	Page E-13
The sound output by the digital piano does not change regardless of how much keyboard pressure I use.	Touch Response is turned off.	Use the SETTING button to turn on Touch Response.	Page E-26
When playing together with another MIDI instrument, keys and tunings do not match.	The Tuning or Transpose setting of the digital piano is something other than "00".	Use the TRANPOSE/KEY CONTROL button or the SETTING button to change the transpose and tuning settings to "00".	Page E-21, 26
I am not able to record Auto Accompaniment or rhythm patterns.	Track 2 (melody-only track), is specified as the recording track.	In record standby, use the TRACK button to select Track 1.	Page E-22
When connected to a computer over a MIDI connection, playing on the keyboard produces unnatural sounds.	The computer's MIDI THRU function is turned on.	Turn off MIDI THRU on the computer, or use the digital piano's CONTROL button to turn off Local Control.	Page E-27
I can't record chord accompaniment data on my computer.	Accomp MIDI Out is turned off.	Use the SETTING button to turn on Accomp MIDI Out.	Page E-27
The microphone does not work.	<ol style="list-style-type: none"> 1. The microphone volume setting is too low. 2. The microphone's switch is turned off. 	<ol style="list-style-type: none"> 1. Increase microphone volume. 2. Turn on the microphone's switch. 	<p>Page E-20</p> <p>Page E-20</p>
There is noise in the microphone output.	Nearby fluorescent lighting or other digital noise source.	Move the microphone away from the source of the noise.	Page E-20



Troubleshooting

Problem	Cause	Action	See Page
I can't store data on a memory card.	<ol style="list-style-type: none"> 1. The card is write-protected. 2. The card is not inserted correctly into the card slot. 3. There is not enough room available on the card. 4. The card has voltage specifications or a capacity that is not supported by this digital piano. 5. There is something wrong with the card. 	<ol style="list-style-type: none"> 1. Remove the write protect sticker from the card. 2. Correctly insert the card into the slot. 3. Use a different card or delete files you no longer need. 4. Use a card of the specified voltage specifications and capacity. 5. Use a different card. 	<p>Page E-29</p> <p>Page E-30</p> <p>Page E-32</p> <p>Page E-29</p>
I can't load data from a memory card.	<ol style="list-style-type: none"> 1. The card is not inserted correctly into the card slot. 2. There is not enough room in the area into which you are trying to load the data. 3. The card has voltage specifications or a capacity that is not supported by this digital piano. 4. There is something wrong with the card. 	<ol style="list-style-type: none"> 1. Correctly insert the card into the slot. 2. Make more room in digital piano memory by deleting downloaded songs, and/or Song Memory data. 3. Use a card of the specified voltage specifications and capacity. 4. Use a different card. 	<p>Page E-29</p> <p>Page E-25, 28</p> <p>Page E-29</p>



Specifications

Model:	PX-400R
Keyboard:	88 piano keys (with touch response)
Polyphony:	32 notes, maximum
Tones:	120 panel tones + 128 GM tones + 10 drum sets; with layer and split
Digital Effects:	Reverb (4 types), Chorus (4 types)
Metronome:	<ul style="list-style-type: none"> • Time Signatures: 0, 2, 3, 4, 5, 6 • Tempo Range: 20 to 255
Auto Accompaniment:	<ul style="list-style-type: none"> • Number of Rhythms: 120 • Tempo Range: 20 to 255 • Modes: Normal; CASIO CHORD; FINGERED; FULL RANGE CHORD • Accompaniment Volume: Adjustable • One Touch Presets: Optimal tone, tempo, layer/auto harmonize on/off settings to match rhythm • Auto Harmonize: 12 types; adds harmony notes to melody in accordance with auto accompaniment chord fingerings.
Built-in Tunes:	<ul style="list-style-type: none"> • Number of Tunes: Piano Group 50 + Song Group 30 + 10 loaded song data (Approximately 132 kilobytes) • Tempo: 20 to 255 • Demo: Sequential looping of all 80 preset tunes • Song Volume: Adjustable
Lesson Function:	Lesson Part: Left hand, right hand
Song Memory:	<ul style="list-style-type: none"> • Number of Songs: Two (1 Song Recording, 1 Free Recording) • Recorded Data: Song Recording: Right-hand part, left-hand part, both-hand parts Free Recording: Track 1 (chord accompaniment), Track 2 (melody) • Recording Method: Real-time • Memory Capacity: Approximately 5,300 notes (two songs)
Pedals:	Damper, Soft/Sostenuto (Selectable)
Registration Memory:	Number of Memory Areas: 16 (4 sets × 4 banks)
Card Slot:	3.3V SmartMedia™
Other Functions:	<ul style="list-style-type: none"> • Touch: 3 types, off • Transpose: 1 octave (F♯ to C to F) • Tuning: A4 = 440.0Hz ±50 cents (adjustable) • Pitch Bend Range: Adjustable (12 semitones upwards and downwards) • Display Contrast: Adjustable
MIDI:	16 multi-timbre receive, GM Level 1 standard
Input/Output:	<ul style="list-style-type: none"> • Headphones: Stereo standard jacks × 2 Output Impedance : 170Ω Output Voltage : 1.1V (RMS) MAX • Pedal: Standard jacks × 2 • LINE OUT (R)(L/MONO): Standard jacks × 2 Output impedance: 2.3kΩ Output voltage: 1.0V (RMS) MAX • MIC IN: Standard jack Input impedance: 3.3kΩ Input voltage: 10mV • Power: 12V DC • MIDI (OUT) (IN) • USB port
Speakers:	(16 cm × 8 cm) × 2 + Ø5 cm × 2 (Output: 8.0W + 8.0W)
Power Supply:	AC Adaptor: AD-12
Power Consumption:	12V --- 18W
Dimensions:	134.2 × 34.9 × 15.7 cm (52 14/16 × 13 12/16 × 6 3/16 inch)
Weight:	Approximately 17.0 kg (37.5 lbs)

• Design and specifications are subject to change without notice.

419A-E-039B

Appendix/Apéndice

Tone List/Lista de sonidos

① Tone Group Name/Nombre de grupo de sonido ③ Tone Name/Nombre de sonidos ⑤ Bank Select MSB/MSB de selección de banco
 ② No./Nº ④ Program Change/Cambio de programa ⑥ Maximum Polyphony/Polifonía máxima

●Panel Tones/Sonidos de panel

①	②	③	④	⑤	⑥
PIANO	000	STEREO PIANO	0	2	16
	001	GRAND PIANO	0	1	32
	002	MELLOW PIANO	0	3	16
	003	ROCK PIANO	1	2	16
	004	DANCE PIANO	1	1	16
	005	HONKY-TONK	3	2	16
	006	OCTAVE PIANO	3	8	16
	007	PIANO PAD	0	8	16
	008	HARPSICHORD	6	2	16
009	COUPLED HARPSICHOR	6	8	16	
E.PIANO/CHROMATIC	000	ELEC.PIANO 1	4	2	32
	001	ELEC.PIANO 2	4	1	16
	002	DYNO ELEC.PIANO	4	3	32
	003	FM ELEC.PIANO	5	2	16
	004	60'S E.PIANO	4	4	32
	005	CHORUSED EP	4	9	16
	006	E.PIANO PAD	5	8	16
	007	ELEC.GRAND PIANO	2	2	32
	008	MODERN E.G.PIANO	2	3	16
	009	CLAVI	7	2	32
	010	VIBRAPHONE	11	2	32
	011	MARIMBA	12	2	32
	012	CELESTA	8	2	32
013	GLOCKENSPIEL	9	2	32	
ORGAN	000	DRAWBAR ORGAN 1	16	2	32
	001	DRAWBAR ORGAN 2	16	1	16
	002	PERC.ORGAN 1	17	2	16
	003	PERC.ORGAN 2	17	3	16
	004	ELEC.ORGAN 1	16	8	16
	005	ELEC.ORGAN 2	16	4	16
	006	JAZZ ORGAN	17	4	16
	007	ROCK ORGAN	18	2	16
	008	CHURCH ORGAN	19	2	32
	009	CHAPEL ORGAN	19	8	32
	010	ACCORDION	21	2	16
	011	OCTAVE ACCORDION	21	8	16
	012	BANDONEON	23	2	16
013	HARMONICA	22	2	32	
GUITAR	000	NYLON STR.GUITAR	24	2	32
	001	STEEL STR.GUITAR	25	2	32
	002	12 STR.GUITAR	25	8	16
	003	JAZZ GUITAR	26	2	32
	004	OCT JAZZ GUITAR	26	8	16
	005	CLEAN GUITAR	27	2	32
	006	ELEC.GUITAR	27	1	16
	007	MUTE GUITAR	28	2	32
	008	OVERDRIVE GT	29	2	32
	009	DISTORTION GT	30	2	32
010	FEEDBACK GT	31	8	16	
BASS	000	ACOUSTIC BASS	32	2	32
	001	RIDE BASS	32	32	16
	002	FINGERED BASS	33	2	32
	003	PICKED BASS	34	2	32
	004	FRETLESS BASS	35	2	32
	005	SLAP BASS	37	2	32
	006	SAW.SYNTH-BASS	38	2	32
007	SQR SYNTH-BASS	39	2	32	
STRINGS/ENSEMBLE	000	STRINGS	48	2	32
	001	SLOW STRINGS	49	2	32
	002	CHAMBER	48	3	16
	003	SYNTH-STRINGS 1	50	2	32
	004	SYNTH-STRINGS 2	51	2	32
005	CHOIR AAHS	52	2	32	

①	②	③	④	⑤	⑥	
STRINGS/ENSEMBLE	006	CHOIRS	52	8	32	
	007	VOICE DOO	53	2	32	
	008	SYNTH-VOICE	54	2	32	
	009	SYNTH-VOICE PAD	54	8	16	
	010	VIOLIN	40	2	32	
	011	CELLO	42	2	32	
	012	PIZZICATO STRINGS	45	2	32	
	013	HARP	46	2	32	
	BRASS	000	TRUMPET	56	2	32
		001	TROMBONE	57	2	32
		002	TUBA	58	2	32
		003	MUTE TRUMPET	59	2	32
		004	FRENCH HORN	60	2	16
005		BRASS	61	2	32	
006		BRASS SECTION	61	3	16	
007		BRASS SFZ	61	8	16	
008		ANALOG SYNTH-BRASS	62	8	16	
009		SYNTH-BRASS 1	62	2	16	
010	SYNTH-BRASS 2	63	2	16		
REED	000	ALTO SAX 1	65	1	16	
	001	ALTO SAX 2	65	2	32	
	002	BREATHY A.SAX	65	8	16	
	003	TENOR SAX 1	66	1	16	
	004	TENOR SAX 2	66	2	32	
	005	BREATHY T.SAX	66	8	16	
	006	T.SAXYS	66	9	16	
	007	SOPRANO SAX	64	2	32	
	008	BARITONE SAX	67	2	32	
	009	OBOE	68	2	32	
010	CLARINET	71	2	32		
PIPE	000	FLUTE 1	73	2	32	
	001	FLUTE 2	73	1	16	
	002	MELLOW FLUTE	73	8	16	
	003	PICCOLO	72	2	32	
	004	RECORDER	74	2	30	
	005	PAN FLUTE	75	2	32	
006	WHISTLE	78	2	32		
SYNTH-LEAD	000	SQUARE LEAD	80	2	16	
	001	SAWTOOTH LEAD	81	2	16	
	002	MELLOW SAW LEAD	81	8	16	
	003	SINE LEAD	80	8	32	
	004	CALLIOPE	82	2	16	
	005	VOICE LEAD	85	2	16	
006	BASS+LEAD	87	2	16		
SYNTH-PAD	000	FANTASY	88	2	16	
	001	WARM PAD	89	2	16	
	002	WARM VOX	89	8	16	
	003	POLYSYNTH	90	2	16	
	004	POLY SAW	90	8	16	
	005	BOWED PAD	92	2	16	
	006	HALO PAD	94	2	16	
	007	ATMOSPHERE	99	2	16	
	008	BRIGHTNESS	100	2	16	
	009	ECHO PAD	102	2	16	
	010	STAR THEME	103	2	16	
	011	SPACE PAD	103	8	16	
012	NEW AGE	88	1	16		
GM TONES	000	GM PIANO 1	0	0	32	
	001	GM PIANO 2	1	0	32	
	002	GM PIANO 3	2	0	32	
	003	GM HONKY-TONK	3	0	16	
	004	GM E.PIANO 1	4	0	32	
005	GM E.PIANO 2	5	0	16		

Appendix/Apéndice

① Tone Group Name/Nombre de grupo de sonido ③ Tone Name/Nombre de sonidos
② No./Nº ④ Program Change/Cambio de programa

⑤ Bank Select MSB/MSB de selección de banco
⑥ Maximum Polyphony/Polidonía máxima

●GM Tones/Drum Sets Sonidos GM/Ajustes de batería

①	②	③	④	⑤	⑥
GM TONES	006	GM HARPSICHORD	6	0	32
	007	GM CLAVI	7	0	32
	008	GM CELESTA	8	0	32
	009	GM GLOCKENSPIEL	9	0	32
	010	GM MUSIC BOX	10	0	16
	011	GM VIBRAPHONE	11	0	32
	012	GM MARIMBA	12	0	32
	013	GM XYLOPHONE	13	0	32
	014	GM TUBULAR BELL	14	0	32
	015	GM DULCIMER	15	0	16
	016	GM ORGAN 1	16	0	16
	017	GM ORGAN 2	17	0	16
	018	GM ORGAN 3	18	0	16
	019	GM PIPE ORGAN	19	0	16
	020	GM REED ORGAN	20	0	32
	021	GM ACCORDION	21	0	16
	022	GM HARMONICA	22	0	32
	023	GM BANDONEON	23	0	16
	024	GM NYLON STR.GUITAR	24	0	32
	025	GM STEEL STR.GUITAR	25	0	32
	026	GM JAZZ GUITAR	26	0	32
	027	GM CLEAN GUITAR	27	0	32
	028	GM MUTE GUITAR	28	0	32
	029	GM OVERDRIVE GT	29	0	32
	030	GM DISTORTION GT	30	0	32
	031	GM GT HARMONICS	31	0	32
	032	GM ACOUSTIC BASS	32	0	32
	033	GM FINGERED BASS	33	0	32
	034	GM PICKED BASS	34	0	32
	035	GM FRETLESS BASS	35	0	32
	036	GM SLAP BASS 1	36	0	32
	037	GM SLAP BASS 2	37	0	32
	038	GM SYNTH-BASS 1	38	0	32
	039	GM SYNTH-BASS 2	39	0	32
	040	GM VIOLIN	40	0	32
	041	GM VIOLA	41	0	32
	042	GM CELLO	42	0	32
	043	GM CONTRABASS	43	0	32
	044	GM TREMOLO STRINGS	44	0	32
	045	GM PIZZICATO	45	0	32
	046	GM HARP	46	0	32
	047	GM TIMPANI	47	0	32
	048	GM STRINGS 1	48	0	32
	049	GM STRINGS 2	49	0	32
	050	GM SYNTH-STRINGS 1	50	0	32
	051	GM SYNTH-STRINGS 2	51	0	32
	052	GM CHOIR AAHS	52	0	32
	053	GM VOICE DOO	53	0	32
	054	GM SYNTH-VOICE	54	0	32
	055	GM ORCHESTRA HIT	55	0	16
	056	GM TRUMPET	56	0	32
	057	GM TROMBONE	57	0	32
	058	GM TUBA	58	0	32
	059	GM MUTE TRUMPET	59	0	32
	060	GM FRENCH HORN	60	0	16
	061	GM BRASS	61	0	32
	062	GM SYNTH-BRASS 1	62	0	32
	063	GM SYNTH-BRASS 2	63	0	16
	064	GM SOPRANO SAX	64	0	32
	065	GM ALTO SAX	65	0	32
	066	GM TENOR SAX	66	0	32
	067	GM BARITONE SAX	67	0	32
	068	GM OBOE	68	0	32
	069	GM ENGLISH HORN	69	0	32
	070	GM BASSOON	70	0	32
	071	GM CLARINET	71	0	32

①	②	③	④	⑤	⑥
GM TONES	072	GM PICCOLO	72	0	32
	073	GM FLUTE	73	0	32
	074	GM RECORDER	74	0	32
	075	GM PAN FLUTE	75	0	32
	076	GM BOTTLE BLOW	76	0	16
	077	GM SHAKUHACHI	77	0	16
	078	GM WHISTLE	78	0	32
	079	GM OCARINA	79	0	32
	080	GM SQUARE LEAD	80	0	16
	081	GM SAWTOOTH LEAD	81	0	16
	082	GM CALLIOPE	82	0	16
	083	GM CHIFF LEAD	83	0	16
	084	GM CHARANG	84	0	16
	085	GM VOICE LEAD	85	0	16
	086	GM FIFTH LEAD	86	0	16
	087	GM BASS+LEAD	87	0	16
	088	GM FANTASY	88	0	16
	089	GM WARM PAD	89	0	16
	090	GM POLYSYNTH	90	0	16
	091	GM SPACE CHOIR	91	0	16
	092	GM BOWED GLASS	92	0	16
	093	GM METAL PAD	93	0	16
	094	GM HALO PAD	94	0	16
	095	GM SWEEP PAD	95	0	16
	096	GM RAIN DROP	96	0	16
	097	GM SOUND TRACK	97	0	16
	098	GM CRYSTAL	98	0	16
	099	GM ATMOSPHERE	99	0	16
	100	GM BRIGHTNESS	100	0	16
	101	GM GOBLINS	101	0	16
	102	GM ECHOES	102	0	16
	103	GM SF	103	0	16
	104	GM SITAR	104	0	16
	105	GM BANJO	105	0	32
	106	GM SHAMISEN	106	0	32
	107	GM KOTO	107	0	32
	108	GM THUMB PIANO	108	0	32
	109	GM BAGPIPE	109	0	16
	110	GM FIDDLE	110	0	32
	111	GM SHANAI	111	0	32
	112	GM TINKLE BELL	112	0	32
	113	GM AGOGO	113	0	32
	114	GM STEEL DRUMS	114	0	16
	115	GM WOOD BLOCK	115	0	32
	116	GM TAIKO	116	0	32
	117	GM MELODIC TOM	117	0	32
	118	GM SYNTH-DRUM	118	0	32
	119	GM REVERSE CYMBAL	119	0	32
	120	GM GT FRET NOISE	120	0	32
	121	GM BREATH NOISE	121	0	32
	122	GM SEASHORE	122	0	16
	123	GM BIRD	123	0	16
	124	GM TELEPHONE	124	0	32
	125	GM HELICOPTER	125	0	32
	126	GM APPLAUSE	126	0	16
	127	GM GUNSHOT	127	0	32
DRUM SETS	128	STANDARD SET 1	0	120	
	129	STANDARD SET 2	1	120	
	130	ROOM SET	8	120	
	131	POWER SET	16	120	
	132	ELECTRONIC SET	24	120	
	133	SYNTH SET 1	25	120	
	134	SYNTH SET 2	30	120	
	135	JAZZ SET	32	120	
	136	BRUSH SET	40	120	
	137	ORCHESTRA SET	48	120	



Appendix/Apéndice

Rhythm List/Lista de ritmos

① Rhythm Group Name/Nombre de grupo de ritmo

② No./Nº

③ Rhythm Name/Nombre de ritmo

①	②	③
POPS	00	POP 1
	01	WORLD POP
	02	8 BEAT POP
	03	SOUL BALLAD 1
	04	POP SHUFFLE 1
	05	8 BEAT DANCE
	06	POP BALLAD 1
	07	POP BALLAD 2
	08	BALLAD
	09	FUSION SHUFFLE
	10	SOUL BALLAD 2
	11	16 BEAT 1
	12	16 BEAT 2
	13	8 BEAT 1
	14	8 BEAT 2
	15	8 BEAT 3
	16	DANCE POP 1
	17	POP FUSION
	18	POP 2
19	POP WALTZ	
DANCE/FUNK	00	DANCE
	01	DISCO 1
	02	DISCO 2
	03	EURO BEAT
	04	DANCE POP 2
	05	GROOVE SOUL
	06	TECHNO
	07	TRANCE
	08	HIP-HOP
09	FUNK	
ROCK	00	POP ROCK 1
	01	POP ROCK 2
	02	POP ROCK 3
	03	FOLKIE POP
	04	POP SHUFFLE 2
	05	ROCK BALLAD
	06	SOFT ROCK
	07	ROCK 1
	08	ROCK 2
	09	HEAVY METAL
	10	60'S SOUL
	11	60'S ROCK
	12	SLOW ROCK
	13	SHUFFLE ROCK
	14	50'S ROCK
	15	BLUES
	16	NEW ORLNS R&R
	17	TWIST
	18	R&B
19	ROCK WALTZ	

①	②	③
JAZZ	00	BIG BAND 1
	01	BIG BAND 2
	02	BIG BAND 3
	03	SWING
	04	SLOW SWING
	05	FOX TROT
	06	JAZZ COMBO 1
	07	JAZZ VOICES
	08	ACID JAZZ
EUROPEAN	00	POLKA
	01	POP POLKA
	02	MARCH 1
	03	MARCH 2
	04	WALTZ 1
	05	SLOW WALTZ
	06	VIENNESE WALTZ
	07	FRENCH WALTZ
	08	SERENADE
LATIN	00	BOSSA NOVA 1
	01	BOSSA NOVA 2
	02	SAMBA 1
	03	SAMBA 2
	04	MAMBO
	05	RHUMBA
	06	CHA-CHA-CHA
	07	MERENGUE
	08	BOLERO
VARIOUS	00	REGGAE
	01	PUNTA
	02	CUMBIA
	03	PASODOBLE
	04	SKA
	05	BLUEGRASS
	06	DIXIE
	07	TEX-MEX
	08	COUNTRY 1
	09	COUNTRY 2
	10	FOLKLORE
	11	JIVE
	12	FAST GOSPEL
	13	SLOW GOSPEL
	14	SIRTAKI
	15	HAWAIIAN
	16	ADANI
	17	BALADI
	18	ENKA
19	STR QUARTET	

①	②	③
FOR PIANO	00	PIANO BALLAD 1
	01	PIANO BALLAD 2
	02	PIANO BALLAD 3
	03	EP BALLAD 1
	04	EP BALLAD 2
	05	BLUES BALLAD
	06	MELLOW JAZZ
	07	JAZZ COMBO 2
	08	RAGTIME
	09	BOOGIE-WOOGIE
	10	ARPEGGIO 1
	11	ARPEGGIO 2
	12	ARPEGGIO 3
	13	PIANO BALLAD 4
	14	6/8 MARCH
	15	MARCH 3
	16	2 BEAT
	17	WALTZ 2
	18	WALTZ 3
19	WALTZ 4	

NOTE

- FOR PIANO group rhythms 10 through 19 consist of chord accompaniments only, without any drums or other percussion instruments. These rhythms do not sound unless CASIO CHORD, FINGERED, or FULL RANGE CHORD is selected as the accompaniment mode. With such rhythms, make sure that CASIO CHORD, FINGERED, or FULL RANGE CHORD is selected before you try playing chords.

NOTA

- Los ritmos del grupo FOR PIANO 10 al 19, consisten de acompañamientos de acordes solamente, sin ninguna batería u otros instrumentos de percusión. Estos ritmos no suenan a menos que se seleccionen CASIO CHORD, FINGERED o FULL RANGE CHORD como el modo de acompañamiento. Con tales ritmos, asegúrese que CASIO CHORD, FINGERED o FULL RANGE CHORD se seleccione antes de intentar ejecutar los acordes.

Appendix/Apéndice

Song List/Lista de canciones

Piano Group List/Lista del grupo de piano

No./Nº	Song name/Nombre de canciones
00	Winter Games
01	Someday My Prince Will Come
02	Hills
03	Frosted Glass
04	Hot Feel
05	Let It Be
06	Over The Rainbow
07	The Entertainer
08	Maple Leaf Rag
09	Fantaisie-Impromptu Op.66
10	Nocturne Op.9-2
11	Etude Op.10-3 "Chanson de l'adieu"
12	Etude Op.25-9
13	Prelude Op.28-7
14	Valse Op.64-1 "Petit Chien"
15	Fröhlicher Landmann
16	Von fremden Ländern und Menschen [Kinderszenen]
17	Träumerei [Kinderszenen]
18	Arabesque
19	La Chevaleresque
20	La Prière d'une Vierge
21	Csikos Post
22	Humoreske
23	La Fille aux Cheveux de Lin
24	Arabesque 1
25	Gymnopédies 1
26	Canon in D Major
27	Menuet [Klavierbüchlein für Anna Magdalena Bach]
28	Invention 1
29	Invention 13
30	Jesus Bleibet Meine Freude
31	Variations on "Ah, Vous Dirai-je, Maman" K.265
32	Sonata K.331 1st Mov. Theme
33	Sonata K.331 3rd Mov. "Turkish March"
34	Serenade [Eine Kleine Nachtmusik]
35	Sonatina Op.36-1 1st Mov.
36	Ode To Joy
37	Sonata Op.13 "Pathétique" 2nd Mov.
38	Sonata Op.27-2 "Moonlight" 1st Mov.
39	Marcia alla turca
40	Für Elise
41	Moments Musicaux Op.94-3
42	Impromptu Op.142-3 "Thema"
43	Chopsticks
44	Neko Funjatta
45	Danny Boy
46	Amazing Grace
47	Grandfather's Clock
48	Long Long Ago
49	Home On The Range

Song Group List/Lista del grupo de sonido

No./Nº	Song name/Nombre de canciones
00	Sara
01	Greensleeves
02	Little Brown Jug
03	We Wish You A Merry Christmas
04	Jingle Bells
05	Silent Night
06	Joy To The World
07	O Christmas Tree
08	When The Saints Go Marching In
09	Auld Lang Syne
10	Under The Spreading Chestnut Tree
11	Come Birds
12	Did You Ever See A Lassie?
13	Sippin' Cider Through A Straw
14	Michael Row The Boat Ashore
15	I've Been Working On The Railroad
16	Aura Lee
17	If You're Happy And You Know It, Clap Your Hands
18	My Darling Clementine
19	Annie Laurie
20	My Bonnie
21	Swanee River (Old Folks At Home)
22	Oh! Susanna
23	Camptown Races
24	Yankee Doodle
25	My Old Kentucky Home
26	Turkey In The Straw
27	Jamaica Farewell
28	Sakura Sakura
29	Waltzing Matilda
30 - 39	Loaded songs (user songs)/ Canciones cargadas (canciones del usuario)

Drum Assignment List/Lista de sonidos de batería

Key/Note Number	STANDARD SET 1	STANDARD SET 2	ROOM SET	POWER SET	ELECTRONIC SET	SYNTH SET 1	SYNTH SET 2	JAZZ SET	BRUSH SET	ORCHESTRA SET
E1 28	High Q									Closed Hi-Hat
F1 29	Scratch Push									Pedal Hi-Hat
F1 30	Scratch Pull									Open Hi-Hat
G1 31	Sicks									Ride Cymbal 1
A1 32	Square Click									
A1 33	Metronome Click									
A1 34	Metronome Bell									
B1 35	Standard1 Kick 2	Standard2 Kick 2	Room Kick 2	Power Kick 2	Electric Kick 2	Synth1 Kick 2	Synth2 Kick 2	Jazz Kick 2	Jazz Kick 2	Jazz Kick 1
C2 36	Standard1 Kick 1	Standard2 Kick 1	Room Kick 1	Power Kick 1	Electric Kick 1	Synth1 Kick 1	Synth2 Kick 1	Jazz Kick 1	Jazz Kick 1	Concert BD 1
D2 38	Standard1 Snare 1	Standard2 Snare 1	Room Snare 1	Power Snare 1	Electric Snare 1	Synth1 Snare 1	Synth2 Snare 1	Jazz Snare 1	Brush Snare 1	Concert SD
E2 40	Standard1 Snare 2	Standard2 Snare 2	Room Snare 2	Power Snare 2	Electric Snare 2	Synth1 Snare 2	Synth2 Snare 2	Jazz Snare 2	Brush Snare 2	Castanets
F2 41	Low Tom 2		Room Low Tom 2	Power Low Tom 2	Electric Low Tom 2	Synth1 Low Tom 2				Concert SD
F2 42	Closed Hi-Hat		Room Low Tom 1	Power Low Tom 1	Electric Low Tom 1	Synth1 Closed HH 1				Timpani F
G2 43	Low Tom 1		Room Mid Tom 2	Power Mid Tom 2	Electric Mid Tom 2	Synth1 Closed HH 2				Timpani G
A2 45	Mid Tom 2		Room Mid Tom 1	Power Mid Tom 1	Electric Mid Tom 1	Synth1 Mid Tom 2				Timpani A
B2 46	Open Hi-Hat		Room High Tom 2	Power High Tom 2	Electric High Tom 2	Synth1 High Tom 2				Timpani B
C3 48	Crash Cymbal 1		Room High Tom 1	Power High Tom 1	Electric High Tom 1	Synth1 High Tom 1				Timpani C
D3 50	High Tom 1					Synth1 High Tom 1				Timpani d
E3 52	Ride Cymbal 1					Synth1 Ride Cymbal				Timpani df
F3 53	Chinese Cymbal				Reverse Cymbal					Timpani e
F3 54	Ride Bell									Timpani f
G3 55	Tambourine					Synth1 Tambourine				
A3 56	Splash Cymbal					Synth1 Cowbell	Synth1 Cowbell			Concert Cymbal 2
A3 57	Cowbell									Concert Cymbal 1
B3 58	Crash Cymbal 2									
B3 59	Vibraslap									
C4 60	Ride Cymbal 2									
C4 61	High Bongo					Synth1 High Bongo				
D4 62	Low Bongo					Synth1 Low Bongo				
E4 64	Mute High Conga					Synth1 Mute Hi Conga				
F4 65	Open High Conga					Synth1 Open Hi Conga				
F4 66	Open Low Conga					Synth1 Open Low Conga				
G4 67	High Timbale									
A4 69	Low Timbale									
A4 68	High Agogo									
B4 70	Low Agogo									
B4 71	Cabasa									
C5 72	Maracas					Synth1 Maracas	Synth1 Maracas			
D5 74	Short High Whistle									
E5 75	Long Low Whistle									
F5 77	Short Guiro									
F5 78	Long Guiro									
G5 79	Claves					Synth1 Claves	Synth1 Claves			
A5 81	High Wood Block									
B5 83	Low Wood Block									
C6 84	Mute Cuica									
D6 86	Open Cuica									
E6 88	Mute Triangle									
	Open Triangle									
	Shaker									
	Jingle Bell									
	Bell Tree									
	Castanets									
	Mute Surdo									
	Open Surdo									
	Applause									



Appendix/Apéndice

Fingered Chord Chart/Cuadro de acordes digitados (Fingered)

Chord Type Root	aug	sus4	7sus4	m add9	mM7	7 ⁵	add9
C							
C [#] /(D ^b)							
D							
(D ^b)/E ^b							
E							
F							
F [#] /(G ^b)							
G							
(G ^b)/A ^b							
A							
(A ^b)/B ^b							
B							

Chord Type Root	M	m	7	m7	dim7	M7	dim	m7 ⁵
C								
C [#] /(D ^b)								
D								
(D ^b)/E ^b								
E								
F								
F [#] /(G ^b)								
G								
(G ^b)/A ^b								
A								
(A ^b)/B ^b								
B								



Operational Precautions

Locating the Unit

Avoid the following locations.

- Areas exposed to direct sunlight and high humidity
- Areas subjected to very low temperatures
- Near a radio, TV, video deck, or tuner (unit can cause interference with audio or video signals)

Care of the Unit

- Never use benzene, alcohol, thinner or other such chemicals to clean the exterior of the unit.
- To clean the keyboard, use a soft cloth dampened with a weak solution of a mild neutral detergent and water. Wring out all excess moisture from the cloth before wiping.

Memory Protection

A built-in lithium battery supplies the power required to retain digital piano settings and memory contents when power is turned off. Should the lithium battery go dead, settings and memory contents (Song Memory data, registration memory data, user songs, display contrast setting, etc.) will be lost whenever you turn off digital piano power. Note that the original built-in lithium battery has a life of about five years from the date the digital piano was manufactured. Be sure to periodically contact your retailer or authorized service provider to have the lithium battery replaced. Note that you will be charged separately for lithium battery replacement.

- Note that CASIO COMPUTER CO., LTD. shall not be held liable for any damages or losses or any claims by third parties arising from corruption or loss of data caused by malfunction or repair of the unit, or from battery replacement.

You may notice lines in the finish of the case of this product. These lines are the result of the molding process used to shape the plastic of the case. They are not cracks or breaks in the plastic, and are no cause for concern.

NOTE

- Unauthorized reproduction of this manual in its entirety or in part is expressly forbidden. All rights reserved.
- CASIO COMPUTER CO., LTD. shall not be held liable for any damages or losses or any claims by third parties arising from use of this product or this manual.
- The contents of this manual are subject to change without notice.

Precauciones durante la operación

Ubicación de la unidad

Evite las siguientes ubicaciones.

- Las áreas expuestas directamente a la luz del sol y alta humedad.
- Areas sujetas a temperaturas muy bajas.
- Cerca de una radio, TV, platina de video o sintonizador (la unidad puede ocasionar interferencias con las señales de audio o video).

Cuidado de la unidad

- No utilice benceno, alcohol, diluyentes u otros agentes químicos para limpiar el exterior de la unidad.
- Para limpiar el teclado, utilice un paño suave humedecido con una solución débil de un detergente neutro suave y agua. Exprima todo exceso de humedad del paño antes de limpiar.

Protección de memoria

Una pila de litio incorporada proporciona la energía necesaria para retener los ajustes del piano digital y contenidos de la memoria, cuando la alimentación está desactivada. En caso de que la pila se agote, los ajustes y contenidos de la memoria (datos de la memoria de canción, datos de la memoria de registro, canciones del usuario, ajuste de contraste del display, etc.) se perderán siempre que desactiva la alimentación del piano digital. Tenga en cuenta que la pila de litio incorporada original tiene una duración de cinco años desde la fecha en que se ha fabricado el piano. Asegúrese de comunicarse periódicamente con su vendedor o agente de servicio autorizado para que reemplacen la pila. Tenga en cuenta que el reemplazo de la pila de litio deberá ser abonado separadamente.

- Tenga en cuenta que CASIO COMPUTER CO., LTD. no asume ninguna responsabilidad ante ningún daño o pérdida, ni tampoco de reclamos hechos por terceras partes que resulten de la alteración o pérdidas de datos de la unidad, debido a una falla de funcionamiento, reparación de la unidad o a un cambio de pila.

Se pueden observar líneas en el acabado de la caja de este producto. Estas líneas son un resultado de un proceso de moldeo usado para dar forma al plástico de la caja. No son grietas ni fisuras en el plástico, por lo tanto no deben ser motivos de preocupación.

NOTA

- Se prohíbe la reproducción de este manual ya sea en forma parcial o completa, sin la autorización expresa correspondiente. Todos los derechos se encuentran reservados.
- CASIO COMPUTER CO., LTD. no asume ninguna responsabilidad ante ningún daño o pérdida, ni tampoco de reclamos hechos por terceras partes que resulten del uso de este producto o de este manual.
- Los contenidos de este manual están sujetos a cambios sin previo aviso.



Blank sheet of lined paper with 12 sets of horizontal lines for writing.





Model PX-400R

MIDI Implementation Chart

Version: 1.0

Function ...	Transmitted	Recognized	Remarks
Basic Channel Default Changed	1 1-16	1-16 1-16	
Mode Default Messages Altered	Mode 3 X *****	Mode 3 X	
Note Number True voice	21-108 *****	0-127 0-127	
Velocity Note ON Note OFF	○ 9nH V = 1-127 X 8nH V = 64	○ 9nH V = 1-127 X 9nH V = 0, 8nH V = XX	XX: no relation XX: sin relación
After Touch Key's Ch's	X X	X ○	
Pitch Bender	○	○	
Control Change	0, 32 ○ 1 X 6, 38 ○*1 7 ○ 10 ○ 11 ○ 64 ○ 66 ○*2 67 ○*2 91 ○ 93 ○ 100, 101 ○ 120 ○ 121 ○	○ ○ ○*1 ○ ○ ○ ○ ○ ○ ○ ○ ○ ○	Bank select Modulation Data entry Volume Pan Expression Damper Sostenuto Soft Reverb send Chorus send RPN LSB, MSB All sound off Reset all controller
Program Change : True #	○ 0-127 *****	○ 0-127 *****	
System Exclusive	○*3	○*3*4	
System Common : Song Pos : Song Sel : Tune	X X X	X X X	
System Real Time : Clock : Commands	○ ○	X X	
Aux Messages : Local ON/OFF : All notes OFF : Active Sense : Reset	X ○ X X	X ○ ○ X	
Remarks	*1 Fine tune and coarse tune send/receive, RPN Null, and pitch bend sense receives *1 Afinación fina y envío/recepción de afinación gruesa, RPN nulo y recepción de captación de inflexión de altura tonal. *2 In accordance with pedal/De acuerdo al pedal. *3 • Reverb type [F0][7F][7F][04][05][01][01][01][01][00][vv][F7] vv=00: Room1, 01: Room2, 04: Hall1, 03: Hall2 • Chorus type [F0][7F][7F][04][05][01][01][01][01][02][00][vv][F7] vv=00: Chorus1, 01: Chorus2, 02: Chorus3, 03: Chorus4 *3 • Tipo de reverberación [F0][7F][7F][04][05][01][01][01][01][01][00][vv][F7] vv=00: Room1, 01: Room2, 04: Hall1, 03: Hall2 • Tipo de chorus [F0][7F][7F][04][05][01][01][01][01][02][00][vv][F7] vv=00: Chorus1, 01: Chorus2, 02: Chorus3, 03: Chorus4 *4 GM on/off GM on = MIDI In Chord Judge off/GM of = MIDI In Chord Judge on *4 Activación/desactivación de GM Activación de GM = Análisis de acordes de entrada MIDI desactivado Desactivación de GM = Análisis de acordes de entrada MIDI activado		

Mode 1 : OMNI ON, POLY
Mode 3 : OMNI OFF, POLY

Mode 2 : OMNI ON, MONO
Mode 4 : OMNI OFF, MONO

○ : Yes
X : No



This recycle mark indicates that the packaging conforms to the environmental protection legislation in Germany.

Esta marca de reciclaje indica que el empaquetado se ajusta a la legislación de protección ambiental en Alemania.

CASIO®

CASIO COMPUTER CO.,LTD.
6-2, Hon-machi 1-chome
Shibuya-ku, Tokyo 151-8543, Japan

 MA0408-B Printed in China
PX400R-ES-1