

FILE MANAGEMENT

The file management capabilities of the camera make it easy to keep track of images. You can protect files against deletion, and even use its DPOF feature to specify images for printing.

Folders

Your camera automatically creates a directory of folders in its built-in flash memory or on the memory card to store images.

Memory Folders and Files

An image you record is automatically stored in a folder, whose name is a serial number. You can have up to 900 folders in memory at the same time. Folder names are generated as shown below.

Example: Name of the 100th folder.

100CASIO

Serial number (3 digits)

Each folder can hold files numbered up to 9,999.

Trying to store the 10,000th file in a folder causes the next serially numbered folder to be created. Folder names are generated as shown below.

Example: Name of the 26th file

CIMG0026.JPG

Extension

Serial number (4 digits)

- The actual number of files you will be able to store on a memory card depends on the image quality settings, capacity of the card, etc.
- For details about the directory structure, see “Memory Directory Structure” on page 94.

Protecting Files

Once you protect a file it cannot be deleted (page 62). You can protect files individually or you can protect all files in memory with a single operation.

To protect a single file

1. In the PLAY mode, press MENU.
2. Select the “PLAY” tab, select “Protect”, and then rock the controller to the right.
 
3. Rock the controller left or right to scroll through files and display the one you want to protect.

4. Rock the controller up or down to select “On”, and then click.

- A file that is protected is indicated by the  mark.
- To unprotect a file, select “Off” in step 4, and then click.

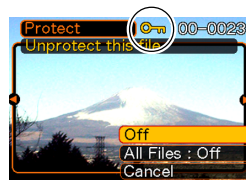

5. Press MENU to exit the menu screen.

To protect all files in memory

1. In the **PLAY** mode, press **MENU**.
2. Select the **“PLAY”** tab, select **“Protect”**, and then rock the controller to the right.
3. Rock the controller up or down to select **“All Files : On”**, and then click.
 - To unprotect all files, click the controller in step 3 so the setting shows **“All Files : Off.”**
4. Press **MENU** to exit the menu screen.

DPOF

The letters “DPOF” stand for “Digital Print Order Format”, which is a format for recording on a memory card or other medium which digital camera images should be printed and how many copies of the image should be printed. Then you can print on a DPOF-compatible printer or at a professional print service in accordance with the file name and number of copies settings recorded on the card.

With this camera, you should always select images by viewing them on the monitor screen. Do not specify images by file name without viewing the file contents.



■ DPOF Settings

File Name,
number of copies,
date

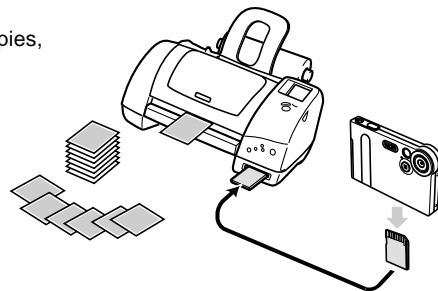

To insert the date during printing

»» NOTE ««

- To insert the date during printing, you need to use the following procedure to turn on the date insertion feature before configuring other print settings.

- In the **PLAY** mode, rock the controller up (DPOF).
- Rock the controller up or down to select “Date”, and then rock the controller to the right.
- Rock the controller up or down to select “On”, and then click.
 - If you do not want the date inserted, select “Off”.

To configure print settings for a single image

- In the **PLAY** mode, rock the controller up (DPOF).



- Rock the controller up or down to select “Select images”, and then rock the controller to the right.



- Rock the controller left or right to scroll through images and display the one you want to print.

4. Rock the controller up or down to specify the number of copies.

- You can specify up to 99 for the number of copies. Specify 00 if you do not want to have the image printed.
- Repeat steps 3 through 4 to configure settings for other images, if you want.

5. Click the controller to complete the procedure.**To configure print settings for all images****1. In the PLAY mode, rock the controller up (DPOF).****2. Rock the controller up or down to select “All images”, and then rock the controller to the right.****3. Rock the controller up or down to specify the number of copies.**

- You can specify up to 99 for the number of copies. Specify 00 if you do not want to have the image printed.

4. Click the controller to complete the procedure.

PRINT Image Matching II

Images include PRINT Image Matching II data (mode setting and other camera setup information). A printer that supports PRINT Image Matching II reads this data and adjusts the printed image accordingly, so your images come out just the way you intended when you recorded them.

* SEIKO EPSON Corporation holds the copyright for PRINT Image Matching and PRINT Image Matching II.



Exif Print

Exif Print is an internationally supported, open standard file format that makes it possible to capture and display vibrant digital images with accurate colors. With Exif 2.2, files include a wide range of shooting condition information that can be interpreted by an Exif Print printer to produce better-looking prints.



»» IMPORTANT! ««

- Information about the availability of Exif Print compatible printer models can be obtained from each printer manufacturer.

Using the FAVORITE Folder

You can copy snapshots from a file storage folder (page 94) to the FAVORITE folder in built-in memory (page 94). This makes it easy to keep track of important files.

To copy a file to the FAVORITE folder

1. In the **PLAY** mode, press **MENU**.

2. Select the **“PLAY”** tab, select **“Favorites”**, and then rock the controller to the right.

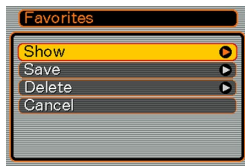

3. Rock the controller up or down to select **“Save”**, and then click.

- This displays the names of the files in built-in memory or on the loaded memory card.



4. Rock the controller left or right to select the file you want to copy to the FAVORITE folder.

5. Rock the controller up or down to select **“Save”**, and then click.

- This copies the displayed file to the FAVORITE folder.

»» NOTES ««

- Copying an image file with the above procedure creates a 320 x 240-pixel QVGA-size image in the FAVORITE folder.
- A file copied into the FAVORITE folder is automatically assigned a file name that is a serial number (0001 to 9999).

To display a file in the FAVORITE folder

1. In the PLAY mode, press MENU.
2. Select the “PLAY” tab, select “Favorites”, and then rock the controller to the right.
3. Rock the controller up or down to select “Show”, and then click.
 - If the FAVORITE folder is empty, the message “No Favorites file!” appears.
4. Rock the controller right (forward) or left (back) to scroll through the files in the FAVORITE folder.



►► NOTE ◀◀

- Holding the controller to the left or right scrolls at high speed.

To delete a file from the FAVORITE folder

1. In the PLAY mode, press MENU.
2. Select the “PLAY” tab, select “Favorites”, and then rock the controller to the right.
3. Rock the controller up or down to select “Delete”, and then click.
4. Rock the controller left or right to select the file you want to delete from the FAVORITE folder.
5. Rock the controller up or down to select “Delete”, and then click.
 - This deletes the file from the FAVORITE folder

►► IMPORTANT! ◀◀

- You cannot use the delete operations on page 62 to delete images from the FAVORITE folder. Performing the memory format operation (page 75), however, does delete FAVORITE folder files.

OTHER SETTINGS

Turning the Key Tone On and Off

Use the following procedure to turn the tone that sounds when you press a key on and off.

1. In the REC mode or PLAY mode, press MENU.
2. Select the “Set Up” tab, select “Beep”, and then rock the controller to the right.
3. Rock the controller up or down to select the setting you want, and then click.

To do this:	Select this:
Turn on the key tone	On
Turn off the key tone	Off

Specifying an Image for the Startup Screen

You can specify an image you recorded with the camera as the startup screen image, which causes it to appear on the monitor screen for about two seconds whenever you turn on the camera.

1. Enter the REC mode or the PLAY mode.
2. Press MENU.
3. Select the “Set Up” tab, select “Startup”, and then rock the controller to the right.
4. Rock the controller left or right to display the image you want to use as the startup image.
5. Rock the controller up or down to select the setting you want, and then click.

To do this:	Select this:
Use the currently displayed image as the startup screen image	On
Disable the startup screen	Off

▶▶ IMPORTANT! ◀◀

- You can select any one of the following types of image as the startup image.
 - The camera's built-in startup image
 - A snapshot you recorded with the camera
 - A movie you recorded with the camera two seconds or less in length and 200KB or less in size
- The snapshot image or movie that you select as the startup image is stored in a special memory location called "startup image memory." Only one image can be stored in startup image memory. Selecting a new startup image overwrites anything that is already stored in startup image memory. Except for the camera's built-in startup image, if you want to return to a previous startup image, you need to have a separate copy of that image in the camera's standard image storage memory.

Changing the Date and Time Setting

Use the following procedure to change the date and time setting.

- 1. In the REC mode or PLAY mode, press MENU.**
- 2. Select the "Set Up" tab, select "Adjust", and then rock the controller to the right.**
- 3. Set the date and the time.**

To do this:	Do this:
Change the setting at the current cursor location	Rock the controller up or down.
Move the cursor between settings	Rock the controller left or right.

- 4. Click to register the settings and exit the setting screen.**

Changing the Date Format

You can select from among three different formats for display of the date.

1. In the REC mode or PLAY mode, press MENU.
2. Select the “Set Up” tab, select “Date Style”, and then rock the controller to the right.
3. Rock the controller up or down to select the setting you want, and then click.

Example: October 23, 2002

To display the date like this:	Select this format:
02/10/23	YY/MM/DD
23/10/02	DD/MM/YY
10/23/02	MM/DD/YY

Changing the Display Language

You can use the following procedure to select one of six languages as the display language.

1. In the REC mode or PLAY mode, press MENU.
2. Select the “Set Up” tab, select “Language”, and then rock the controller to the right.
3. Rock the controller up or down to select the option you want, and then click.

日本語 : Japanese

English : English

Français : French

Deutsch : German

Español : Spanish

Italiano : Italian

Formatting Built-in Memory

Formatting built-in memory deletes any data stored in it.

►► IMPORTANT! ◀◀

- Note that data deleted by a format operation cannot be recovered. Check to make sure you do not need any of the data in memory before you format it.
- Formatting memory deletes all files in memory, even files that are protected (page 65).

1. Check to make sure there is no memory card loaded in the camera.

- If there is a memory card loaded in the camera, remove it (page 77).

2. In the REC mode or PLAY mode, press MENU.

3. Select the “Set Up” tab, select “Format”, and then rock the controller to the right.

4. Rock the controller up or down to select “Format”, and then click.

- To exit the format operation without formatting, select “Cancel”.

USING A MEMORY CARD

You can expand the storage capabilities of your camera by using a commercially available memory card (SD memory card or MultiMedia Card). You can also copy files from built-in flash memory to a memory card and from a memory card to flash memory.

- Normally, files are stored in built-in flash memory. When you insert a memory card, however, the camera automatically stores files to the card.
- Note that you cannot save files to built-in memory while a memory card is installed in the camera.

▶▶ IMPORTANT! ◀◀

- Make sure you turn off the camera before inserting or removing a memory card.
- Be sure to orient the card correctly when inserting it. Never try to force a memory card into the slot when you feel resistance.
- See the instructions that come with the memory card for information about how to use it.
- Certain types of cards can slow down processing speeds.
- SD memory cards have a write protect switch, which you can use to protect against accidental deletion of image data. Note, however, if you write protect an SD memory card, you must remove write protection whenever you want to record to it, format it, or delete any of its files.

Using a Memory Card

To insert a memory card into the camera

1. Making sure that the contacts of the memory card are facing towards the top of the camera, carefully insert the card into the slot as far as it will go.

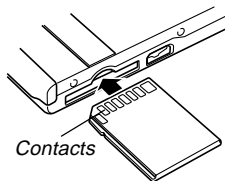

To remove a memory card from the camera

1. Press the memory card into the camera and then release it. This will cause the card to come part way out of the camera.
2. Pull the memory card out of the slot.

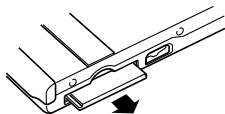
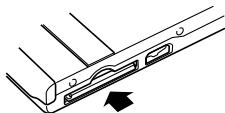

IMPORTANT!

- Never insert any other object besides a memory card into the camera's card slot. Doing so creates the risk of damage to the camera and card.
- If you are not using a memory card, be sure to insert the dummy card into this slot to protect against dust and damage.
- The dummy card is intended for use with this camera only. Never insert it into the card slot of any other type of device.
- Should water or any foreign object ever get into the card slot, immediately turn off the camera, remove the battery, and contact your dealer or nearest CASIO authorized service center.
- Never remove a card from the camera while the operation/flash charge lamp is flashing. Doing so can cause the files save operation to fail, and even damage the memory card.

Formatting a Memory Card

Formatting a memory card deletes any data already stored on it.

▶▶ IMPORTANT! ◀◀

- Be sure to use the camera to format a memory card. Formatting a memory card on a computer and then using it in the camera can slow down data processing by the camera. In the case of an SD card, formatting on a computer can result in non-conformity with the SD format, causing problems with compatibility, operation, etc.
- Note that data deleted by a memory card format operation cannot be recovered. Check to make sure you do not need any of the data on the memory card before you format it.
- Formatting a memory card that contains files deletes all the files, even those that are protected (page 65).

- 1. Load the memory card into the camera.**
- 2. Turn on the camera. Next, enter the REC mode or PLAY mode and press MENU.**
- 3. Select the “Set Up” tab, select “Format”, and then rock the controller to the right.**
- 4. Rock the controller up or down to select “Format”, and then click.**
 - To exit the format operation without formatting, select “Cancel”.

Memory Card Precautions

- Use only an SD memory card or a MultiMediaCard with this camera. Proper operation is not guaranteed when any other type of card is used.
- Electrostatic charge, electrical noise, and other phenomena can cause data to become corrupted or even lost. Always make sure that you always back up important data on other media (MO disc, computer hard disk, etc.)
- If a memory card starts to behave abnormally, you can restore normal operation by reformatting it. However, we recommend that you always take along more than one memory card whenever using the camera far away from the home or office.
- We recommend that you format a memory card before using it for the first time after purchasing it, or whenever the card you are using seems to be the cause of abnormal images.
- Before starting a format operation, check to make sure that the battery is fully charged. Power interruption during the format operation can result in improper formatting, and even damage the memory card and make it unusable.

Copying Files

Use the procedures below to copy files between built-in memory and a memory card.

To copy all the files in built-in memory to a memory card

1. Load the memory card into the camera.
2. Turn on the camera. Next, enter the PLAY mode and press MENU.
3. Select the “PLAY” tab, select “Copy”, and then rock the controller to the right.



4. Rock the controller up or down to select “Built-in → Card”, and then click.

- This starts the copy operation and displays the message “Busy... Please wait...”
- After the copy operation is complete, the monitor screen shows the last file in the folder.

To copy a file from a memory card to built-in memory

- 1. Perform steps 1 through 3 of the procedure under “To copy all the files in built-in memory to a memory card.”**
- 2. Rock the controller up or down to select “Card → Built-in”, and then click.**
- 3. Rock the controller left or right to select the file you want to copy.**
- 4. Rock the controller up or down to select “Copy”, and then click.**
 - This starts the copy operation and displays the message “Busy... Please wait...”
 - The file reappears on the monitor screen after the copy operation is complete.

USING THE CAMERA WITH A COMPUTER

The USB cradle that comes with your camera makes it easy to connect to a computer that is equipped with a USB port. You can also transfer files using the memory card, if your computer is equipped to read memory cards.

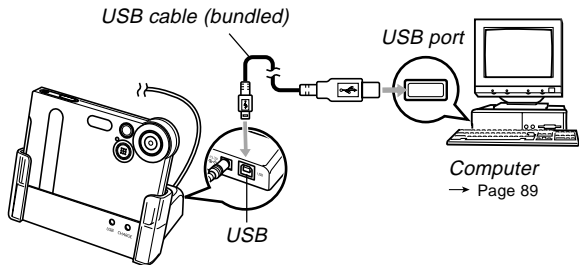

Installing the Software from the CD-ROM

Before you can exchange files with your computer, you first need to install the software contained on the CD-ROM that comes with the camera.

About the bundled CD-ROM

The CD-ROM that comes bundled with the camera contains the following software.

Photo Loader (for Windows/Macintosh)

This application loads image data saved in JPEG and AVI format from a digital camera onto your computer.

Photohands (for Windows)

This application is for retouching and printing image files.

USB Driver for Mass Storage (for Windows/Macintosh)

This is the software that makes it possible for the camera to “talk” to your personal computer over a USB connection. If you are using Windows XP, Mac OS 9, or Mac OS X, do not install the USB driver from the CD-ROM. With these operating systems, you will be able to perform USB communication simply by connecting the camera to your computer with the USB cable.

Internet Explorer (for Macintosh)

This is a browser application for reading HTML files. Images loaded by Photo Loader are stored in folders called “Libraries.” Internet Explorer displays the contents of a library on your computer screen.

DirectX (for Windows)

This software provides an extended tool set including a codec that allows Windows 98 and 2000 to handle movie files recorded using a digital camera. You do not need to install DirectX if you are running Windows XP or Me.

Acrobat Reader (for Windows/Macintosh)

This is an application that lets you read PDF files. Use it to read the user documentation for the camera, Photo Loader, and Photohands, all of which is included on the bundled CD-ROM.

NOTE

- See the user documentation files (PDF) on the bundled CD-ROM for details about using Photo Loader and Photohands. See “Viewing User Documentation (PDF files)” on page 85 (Windows) and page 88 (Macintosh) of this manual for more information.

Computer System Requirements

Computer system requirements depend on each of the applications, as described below.

Windows

See the “Readme” file on the bundled CD-ROM.

Macintosh

See the “readme” file on the bundled CD-ROM.

Installing Software from the CD-ROM in Windows

Use the procedures in this section to install the software from the bundled CD-ROM to your computer.

NOTE

- You do not need to install software if you already have it installed on your computer.

The CD-ROM includes the software and user documentation for various languages. Check the CD-ROM menu screen to see if applications and user documentation are available for a particular language.

Getting Started

Start up your computer and insert the CD-ROM into its CD-ROM drive. This will automatically launch the menu application, which displays a menu screen on your computer.



NOTE

- The menu application may not start up automatically on some computers. If this happens, navigate to the CD-ROM and double-click “menu.exe” to launch the menu application.

Selecting a Language

First select a language. Note that some software is not available in all languages.

- On the menu screen, click the language button in the upper left corner of the display.
- On the list of languages that appears, select the one you want.

Viewing the Contents of the “Read me” File

You should always read the “Read me” file for any application before installing it. The “Read me” file contains information you need to know when installing the application.

1. On the menu screen, click “Software.”
2. Click the name of the application you want to install.
3. Click the “Read me” button.

»» IMPORTANT! ««

- Before upgrading or reinstalling Photo Loader, or before installing it onto another computer, be sure to read the “Read me” file for information about retaining existing libraries.

Installing an Application

1. On the menu screen, click “Software.”
2. Click the name of the application you want to install.
3. Click the “Install” button.
4. Follow the instructions that appear on your computer screen.

»» IMPORTANT! ««

- Be sure to follow the instructions carefully and completely. If you make a mistake when installing Photo Loader, you may not be able to browse your existing library information and HTML files that are created automatically by Photo Loader. In some cases, image files may be lost.
- When using an operating system other than Windows XP, never connect the camera to your computer without installing the USB driver from the CD-ROM first.

Viewing User Documentation (PDF Files)

1. On the menu screen, click “Manual.”
2. Click the name of the application whose user documentation you want to read.
3. Click the “Read” button.

▶▶ IMPORTANT! ◀◀

- You need to have Adobe Acrobat Reader installed on your computer to read user documentation files. If you do not already have Adobe Acrobat Reader installed, you can install it from the bundled CD-ROM.

Exiting the Menu Application

1. On the menu screen, click “Exit” to exit the menu.

Installing Software from the CD-ROM on a Macintosh

The CD-ROM contains applications and user documentation in various languages in folders named for each language: English, French, German, Spanish, Italian, Dutch, and Chinese. Check the CD-ROM folders to find out if applications and user documentation are available in a particular language.

File names include one of the following codes that indicate the language of the data contained in the file as shown below.

English: e, French: f, German: g, Spanish: sp, Italian: i, Dutch: du, Chinese: ct

If your language is not included in the above, use the contents of the “English” folder.

Installing Software

Use the following procedures to install the software. We recommend that you install Internet Explorer and Outlook Express first before installing Photo Loader and Acrobat Reader.

■ **To install Internet Explorer and Outlook Express**

1. Open the file named “Internet Explorer.”
2. Open the folder for the language version you want to install, and then open the file named “readme_casio” file.
3. Follow the instructions in the read me file to install Internet Explorer and Outlook Express.

■ **To install Photo Loader**

1. Open the folder named “Photo Loader.”
2. Open the folder named “English,” and then open the file named “Important.”
3. Open the folder named “Installer,” and then open the file named “readme.”
4. Follow the instructions in the “readme” file to install Photo Loader.

►► **IMPORTANT!** ◀◀

- If you are upgrading to the new version of Photo Loader from a previous version and you want to use library management data and HTML files created using the old version of Photo Loader, be sure to read the “Important” file in the “Photo Loader” folder. Follow the instructions in the file to use your existing library management files. Failure to follow this procedure correctly can result in loss or corruption of your existing files.

■ **To install Acrobat Reader**

1. On the bundled CD-ROM, open the folder named “Acrobat Reader.”
2. Open the folder for the language whose version of Acrobat Reader you want to install, and then open the file named “readme_casio.”
 - Follow the instructions in the read me file to install Acrobat Reader.

■ Installing the USB Driver

1. Turn off the camera and quit all applications on your Macintosh.
2. Insert the bundled CD-ROM provided into the CD-ROM drive.
3. Open the hard disk that is specified as the startup disk.
4. Open the “System Folder” on the startup disk.
5. Open the “Extensions” folder inside the “System Folder.”
6. Open the “USB Driver” folder on the CD-ROM.
7. Drag “CASIO-USB Storage Driver” and “CASIO-USB Storage Class Shim” from the “USB Driver” folder to the “Extensions” folder.
8. Confirm that the “CASIO-USB Storage Driver” file and “CASIO-USB Storage Class Shim” file are in the “Extensions” folder, and then restart your Macintosh.

9. After the system starts up, use the USB cable to connect the camera to your Macintosh.

10. Turn on the camera.

11. From now on, the camera will be recognized as a drive whenever you connect the camera to your Macintosh.

- The shape of the icon that appears on your Macintosh display depends on the version of your Mac OS.



»» IMPORTANT! ««

- If you are running an operating system other than Mac OS 9 or Mac OS X, do not connect the camera to your Macintosh PC without installing the USB driver first.
- **To uninstall the USB driver**
Delete “CASIO-USB Storage Driver” and “CASIO-USB Storage Class Shim” from the “Extensions” folder.

Viewing User Documentation (PDF Files)

To perform the following procedures, you must have Acrobat Reader installed on your Macintosh (page 86).

1. On the bundled CD-ROM, open the folder named “Acrobat Reader.”
2. Open the folder for the language whose version of Acrobat Reader you want to install, and then open the file named “readme_casio.”
3. Follow the instructions in the read me file to install Acrobat Reader.

■ To view the camera user’s guide

1. On the CD-ROM, open the “Manual” folder.
2. Open the “Digital Camera” folder, and then open the folder for the language whose user’s guide you want to view.
3. Open the file named “camera_xx.pdf.”
4. “xx” is the language code (English: e, French: f, German: g, Spanish: sp, Italian: i, Dutch: du, Chinese: ct).

■ To read the Photo Loader user’s guide

1. On the CD-ROM, open the “Manual” folder.
2. Open the “Photo Loader” folder and then open the “English” folder.
3. Open “PhotoLoader_english.”

Transferring Files to a Computer

The CD-ROM that comes bundled with your camera contains a copy of Photo Loader and a USB driver. This software lets you transfer the contents of the camera's memory to your computer quickly and easily. Photo Loader and the Photohands application can also be used for high-level image management and editing.

- For information about using Photo Loader and Photohands, see their user documentation files (PDF) on the bundled CD-ROM.

Transferring Files Over a USB Connection

Connecting the bundled USB cradle to a computer that is equipped with a USB port makes it possible to transfer files to a computer simply by placing the camera onto the cradle.

- Note that you need to install a USB driver on your computer (page 81). Once you use the cradle to establish a USB connection, the computer sees the camera as an external storage device (card reader/writer).
- If you plan to transfer files from the camera's built-in memory to your computer, make sure there is no memory card loaded in the camera. If there is, remove the memory card from the camera before you place it onto the cradle.

NOTE

- Do not install USB driver from the CD-ROM onto a computer running Windows XP, or Mac OS 9 or Mac OS X. With these operating systems, USB communication becomes enabled simply by connecting the camera to the computer with the USB cable.

■ To connect the USB Cable

1. Connect the AC power cord to the AC adaptor, and then plug the other end of the AC power cord into a household power outlet.
2. Connect the AC adaptor to the DC IN 5.3V connector of the USB cradle.

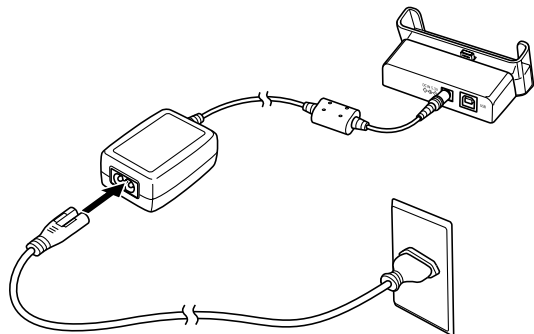

3. Plug Connector B on the bundled USB cable to the USB port of the USB cradle.

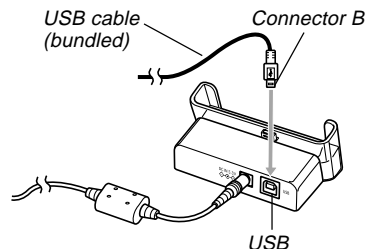

4. Shut down your computer, and plug Connector A of the cable into its USB port. Next, start up your computer.

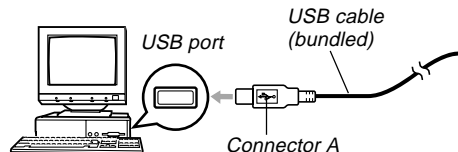

USING THE CAMERA WITH A COMPUTER

5. Turn off the camera and remove its connector cover.

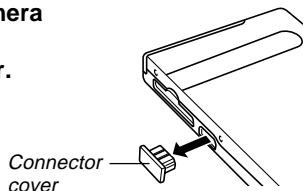

6. Making sure that the camera is turned off, set it onto the USB cradle.

- Do not place the camera onto the USB cradle while it is turned on.

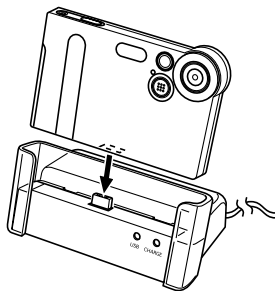

7. Turn on the camera.

- When you turn on the camera, it enters the USB Mode and automatically transfers the files in camera memory to the computer.
- While the camera is in the USB Mode, the USB lamp on the cradle lights green (page 109).

▶▶ IMPORTANT! ◀◀

- Be sure to read the applicable information in the user documentation that comes with your computer before connecting the USB cradle.
- Do not leave the same image displayed on your computer screen for a long time. Doing so can cause the image to "burn in" on the screen.
- Take care when connecting the USB cable to the USB cradle. The USB port and the cable plug are shaped for proper positioning.
- Plug the USB cable into the ports securely as far as it will go. Proper operation is not possible if connections are not correct.
- Be sure to connect the AC adaptor to the USB cradle to supply power to the camera.
- The optionally available CASIO QC-1U USB cable cannot be used with this camera.
- Never disconnect the USB cable while the PC is accessing camera memory (indicated by a flashing USB lamp). Doing so can cause data to become corrupted.
- You can perform data communication in either the REC mode or PLAY mode.

■ Terminating a USB Connection

Windows XP, Me or 98

Turn off the camera, and then remove the camera from the USB cradle.

Windows 2000

Click card services in the task tray on your computer screen, and disable the drive number assigned to the camera. Next, turn off the camera, and then remove the camera from the USB cradle.

Macintosh

In Finder, drag the camera to the Trash. Next, turn off the camera, and then remove the camera from the USB cradle.

Using a Memory Card to Transfer Images to a Computer

The procedures in this section describe how to transfer images from the camera to your computer using a memory card.

Using a Computer with a Built-in SD Memory Card Slot

Insert the SD memory card directly into the slot.

Using a Computer with a Built-in PC Card Slot

Use a commercially available PC card adapter (for an SD memory card/MMC). For full details, see the user documentation that comes with the PC card adapter and your computer.

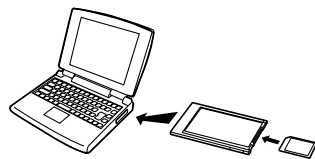

Using a Commercially Available SD Memory Card Reader/Writer

See the user documentation that comes with the SD memory card reader/writer for details about how to use it.

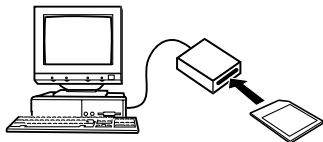

Using a Commercially Available PC Card Reader/Writer and PC Card Adapter (for SD Memory Cards and MMCs)

See the user documentation that comes with the PC card reader/writer and PC card adapter (for an SD memory card/MMC) for details about how to use them.

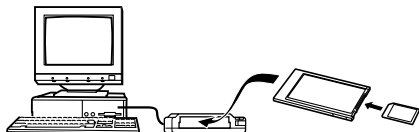

Memory Data

Images recorded with this camera and other data are stored in memory using DCF (Design Rule for Camera File System) protocol. DCF protocol is designed to make it easier to exchange image and other data between digital cameras and other devices.

■ DCF Protocol

DCF devices (digital cameras, printers, etc.) can exchange images with each other. DCF protocol defines camera format for image file data and the directory structure for camera memory, so images can be viewed using another manufacturer's DCF camera or printed on a DCF printer.

Memory Directory Structure

■ Directory Structure

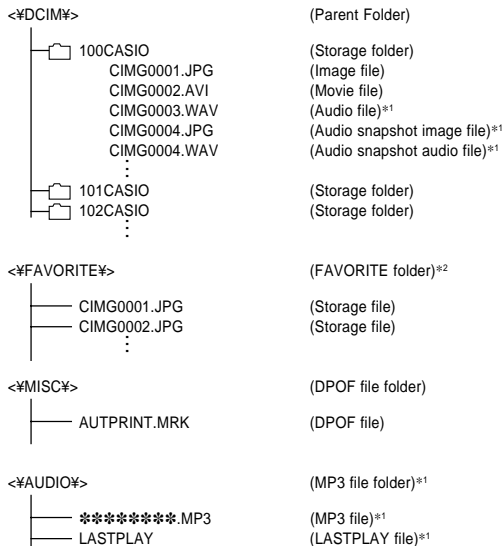

*1 These folders and files are for the EX-M2 only.

*2 These folders are created in built-in memory only.

■ Folder and File Contents

- Parent folder
Folder that stores all of the digital camera files.
- Storage folder
Folders for storing files stored with the digital camera.
- Image file
File that contains an image recorded with the digital camera.
- Movie file
File that contains a movie recorded with the digital camera.
- Audio file
File that contains an audio recording.
- Audio snapshot image file
File that contains the image part of an audio snapshot.
- Audio snapshot audio file
File that contains the audio part of an audio snapshot.
- FAVORITE folder
Folder that contains Favorites image files.
- DPOF file folder
Folder that contains DPOF files.
- MP3 files folder
Folder that contains MP3 files.
- LASTPLAY file
File that contains information about the last played MP3 file.

Image Files Supported by the Camera

- Image files recorded with the CASIO EX-S2/EX-M2 Digital Camera
- DCF protocol image files

Certain DCF functions may not be supported. When displaying an image recorded on another camera model, it may take a long time for the image to appear on the display.

Built-in Memory and Memory Card Precautions

- Note that the folder named “DCIM” is the parent (top) folder of all the files in memory. When transferring memory contents to a hard disk, MO disk, or other external storage, treat all the contents inside a DCIM folder as a set and always keep them together. You can change the name of the DCIM folder on your computer. Changing the name to a date is a good way to keep track of multiple DCIM folders. However, be sure you change the name of the DCIM folder back to “DCIM” before you copy it back to memory for playback on the camera. The camera does not recognize any folder name other than DCIM.
- We also strongly recommend that after transferring data from memory to other external storage that you reformat memory and delete its contents before using it to store more files. Remember that formatting memory deletes all of its contents. Check to make sure that you no longer need any of the files in memory before you format it.

PLAYING AN AUDIO FILE (EX-M2 Only)

You can transfer MP3 music data files from your computer to the camera and then use the camera as a portable audio player.

- MP3 stands for MPEG Audio Layer-3, which is the name of audio compression technology.
- Supported Files
MPEG-1 Audio Layer-3
Bit Rate: 32 to 320 kbps, VBR-compatible
Sampling Frequencies: 32, 44.1, 48kHz
- Maximum Number of Playback Files: 999

▶▶ IMPORTANT! ◀◀

- Depending on the MP3 file format, some music data may not be playable.
- A bit rate of 128kbps and a sampling frequency of 44.1kHz are recommended for MP3 files.
- It is up to you to obtain software for creating MP3 files and to create the MP3 files you want to play.

Transferring Audio Files to the Camera

- 1. Establish a connection between the camera and your computer (page 89).**
- 2. Transfer the MP3 files from your computer to the camera's AUDIO file.**
 - If you cannot find a folder named AUDIO in camera memory, create one at the location indicated under "Memory Directory Structure" on page 94.

Preparing the Camera for Audio Player Operation

Perform the following steps to prepare the camera for operation as an audio player.

1. Turn off the camera and remove its connector cover.

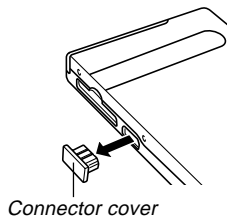

2. Connect the LCD remote controller to the camera's connector, and then plug the stereo headphones into the Headphones jack of the LCD remote controller.

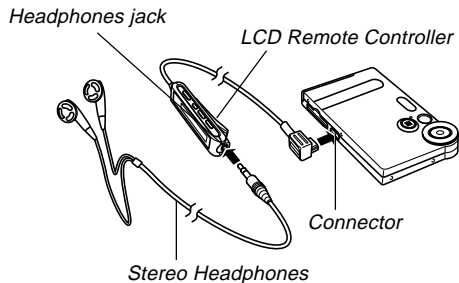

3. Align the mode selector with "AUDIO".

- This enters the AUDIO mode for playback audio data.
- Press the [▶/■] button on the LCD remote controller to turn on the camera and start playback.

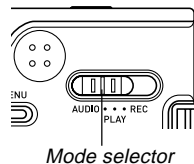

▶▶ IMPORTANT! ◀◀

- All remote controller buttons are disabled when the camera's mode selector is set to "REC" or "PLAY".
- The camera's monitor screen is off while the camera is in the AUDIO mode. Except for the power button, all other camera buttons are disabled.
- Never try to connect any other type of remote controller besides the one that comes with the camera. Also, never try to use the supplied remote controller with any other type of device.
- You cannot play MP3 file data through the camera's built-in speaker.

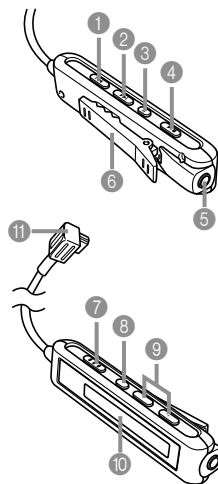
Using the Camera as an Audio Player**General Guide****● LCD Remote Controller**

- 1 [◀◀] (Skip Back/Fast Reverse)
- 2 [▶▶] (Skip Forward/Fast Forward)
- 3 [||] (Pause)
- 4 [▶/■] (Play/Stop)
- 5 Headphones jack (ø3.5mm stereo mini jack)
- 6 Clip
- 7 Lock switch
- 8 Playback mode button
- 9 Volume buttons
- 10 LCD
- 11 Camera connector

PLAYING AN AUDIO FILE (EX-M2 Only)

● Display

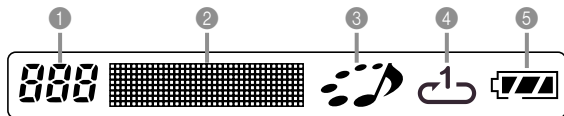

- 1 Track number**
Shows the track number of the current track.
- 2 Track name, artist name, playback time, volume level**
 - Shows the ID3 tag (ID3V1), which is the track name and artist name (alphabetic characters only), contained in the file.
 - During fast forward and fast reverse, shows the elapsed play time.
 - During volume level adjustment, shows the current volume level.
- 3 Playback status indicator**
This icon indicates the current playback status.

This type of icon:	Indicates this:
Rotation clockwise while flashing	Playback is in progress.
Flashing	Playback is paused.
Steady and unmoving	Playback is stopped.

- 4 Playback mode indicator**
This icon indicates the playback mode.

This type of icon:	Indicates this:
Off	Normal playback
	All track repeat
	1-track repeat

- 5 Battery level indicator**

Basic Remote Controller Operations

● To start playback

Press the [▶/■] button. The remote controller beeps to indicate that playback has started.

- Pressing the [▶/■] button while the camera is off turns on power and starts playback.

● To pause playback

Press the [||] button (remote controller beeps).

Pressing the [▶/■] button resumes playback (remote controller beeps).

- If you leave playback paused for about two minutes, the camera and remote controller turn off automatically.

● To fast forward the playback

Hold down the [▶▶] button for a few seconds until fast forward starts.

● To fast reverse the playback

Hold down the [◀◀] button for a few seconds until fast reverse starts.

● To skip to the beginning of the current track

Press the [◀◀] button (remote controller beeps).

To skip to the beginning of a previous track, press the [◀◀] button multiple times (remote controller beeps). The current track number is shown on the LCD.

● To skip to the beginning of the next track

Press the [▶▶] button (remote controller beeps).

To keep skipping forward, press the [▶▶] button multiple times (remote controller beeps). The current track number is shown on the LCD.

● To stop playback

Press the [▶/■] button (remote controller beeps).

● To adjust volume

Press the [+] or [-] volume buttons to adjust volume to the desired level. The LCD shows the current volume level.

● To turn off power

Press the camera's power button.

- Camera power also turns off automatically if you do not perform an operation for about 10 seconds after playback is stopped.



▶▶ IMPORTANT! ◀◀

- The button operation tone does not sound if the camera's button tone function is turned off (page 72).
- You cannot use fast forward, fast reverse, or skip while the current volume level is shown on the LCD.

Specifying the Audio Playback Mode

You can use the following procedure to select one of three playback modes: normal playback, all-track repeat, or 1-track repeat.

- In the AUDIO mode, start audio playback.**
 - The initial default mode is normal playback.
- Press the remote controller's playback mode button to cycle through the playback modes. The playback mode indicator on the LCD indicates the currently selected mode.**

To do this:	Select this mode:	Which is indicated by this icon:
Play all tracks in order and then stop	Normal	Off
Play all tracks in order in an endless loop	All-track repeat	
Play the current track in an endless loop	1-track repeat	

Selecting a Specify Track for Playback

You can use the following procedure to display a list of available tracks and select one of them for playback.

- While AUDIO mode playback is stopped or paused, click the camera's controller.**

- This turns on the monitor screen, which shows a list of information about each track, including track number, track name, and play time.



Currently selected track

- Rock the controller up or down to move the highlighting to the track you want to select.**
 - If move the highlighting to the top or the bottom of the list, the list will scroll to show other tracks.

3. Press the remote controller's [▶/■] button to start playback from the currently selected track.

»» NOTE ««

- The monitor screen turns off automatically if you do not perform any operation for about 10 seconds.

Specifying the Track Playback Sequence

Normally, all tracks in memory are played back in the order they are saved. You can use the following procedure to create a play list that tells the camera the sequence to use when playing back AUDIO mode tracks.

1. On your computer, use your word processor or another text editor to create a file named "PLAYLIST.TXT".
2. Configure the play list by specifying the tracks you want to play in the sequence you want to play them.
 - See "Example PLAYLIST.TXT File Contents" on page 103 for information about how to configure a play list.
3. Place the camera onto the USB cradle and establish a link with your computer (page 90).
4. Place the "PLAYLIST.TXT" file into the "AUDIO" folder of the camera.

■ Example Folder Structure

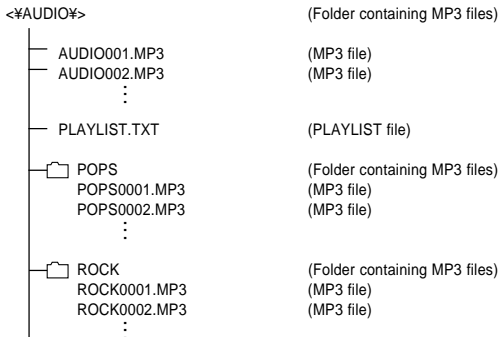

■ Example PLAYLIST.TXT File Contents

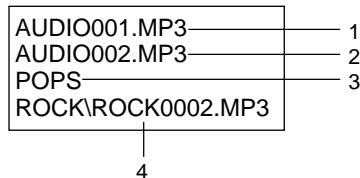

The above PLAYLIST.TXT file specifies the following playback sequence.

1. Playback the MP3 file named AUDIO001.MP3.
2. Playback the MP3 file named AUDIO002.MP3.
3. Playback all the files in the folder named POPS.
4. Playback the MP3 file named ROCK0002.MP3, which is located in folder named ROCK.

▶▶ NOTES ◀◀

- If there is no PLAYLIST.TXT file in the camera's AUDIO folder, all tracks are played back in the order they are saved in memory.
- Playback of any tracks that are not included in the PLAYLIST.TXT file is skipped.
- To change to a different playback sequence, replace PLAYLIST.TXT with another PLAYLIST.TXT file.
- When there is a PLAYLIST.TXT file in the AUDIO folder, only the tracks in the file appear on the camera's monitor screen.

Disabling Remote Controller Button Operations

The remote controller has a lock switch that you can use to disable button operations to guard against accidental operation. To disable all remote controller button operations, slide the lock switch in the direction indicated by the ► mark.

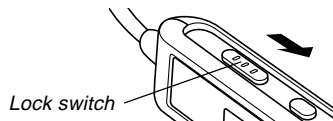

- To re-enable remote controller button operations, slide the lock switch back in the other direction.

▶▶ NOTE ◀◀

- The camera's power button continues to be operational, even while remote controller button operations are disabled.

LCD Remote Control Error Messages

The following describes the error messages that appear on the LCD remote controller's display.

	Cause	Action
NoData	Playback attempted when there is no MP3 data in memory.	Transfer MP3 file data to the "AUDIO" folder of built-in memory or the memory card.

Audio Playback Precautions

- Listening to audio at a high volume for long periods can damage your hearing. Particular care is required when first starting a playback operation.
- Never use the headphones, try to perform fine adjustment, or look at the monitor screen while driving a car, riding a motorcycle, or operating any other type of motor vehicle. Doing so creates the risk of traffic accident. When walking, take special care to remain aware of traffic and road conditions around you.

APPENDIX











Menu Reference





The following shows lists of menus that appear in the REC mode and PLAY mode, and their settings.

- The settings that are underlined in the following table are initial defaults.

■ REC Mode

● REC tab menu

REC Mode	EX-S2:  (Snapshot) /  (Best Shot) /  (Movie)
	EX-M2:  (Snapshot) /  (Best Shot) /  (Movie) /  (Snapshot Audio) /  (Voice Recording)
Flash	<u>Auto</u> /  (Flash Off) /  (Flash On) /  (Red-eye reduction)
Self-timer	10 sec / <u>Off</u>
Indicators	<u>LCD-ON</u> / LCD-OFF
Size	<u>1600 x 1200</u> / 1280 x 960 / 640 x 480
Quality	Fine / <u>Normal</u> / Economy
Digital Zoom	<u>On</u> / Off
Review	On / <u>Off</u>
EV Shift	-2.0 / -1.7 / -1.3 / -1.0 / -0.7 / -0.3 / <u>0.0</u> / +0.3 / +0.7 / +1.0 / +1.3 / +1.7 / +2.0

White Balance	<u>Auto</u> /  (Sunlight) /  (Shade) /  (Light Bulb) /  (Fluorescent) / Manual
L/R Key	<u>REC Mode</u> / EV shift / Flash / White Balance / Off

● Memory tab menu

REC Mode	On / <u>Off</u>
Flash	<u>On</u> / Off
Digital Zoom	<u>On</u> / Off
White Balance	On / <u>Off</u>

● Set Up tab menu

Beep	<u>On</u> / Off
Startup	On / <u>Off</u>
Date Style	<u>YY/MM/DD</u> / DD/MM/YY / MM/DD/YY
Adjust	Time setting
Language	日本語 / <u>English</u> / Français / Deutsch / Español / Italiano
Format	Format / <u>Cancel</u>

■ PLAY Mode

● PLAY tab menu

Zoom	
Protect	<u>On/Off</u> / All Files : On/Off / Cancel
Dubbing	*EX-M2 only
Resize	<u>640 x 480</u> / 320 x 240 / Cancel
Copy	<u>Built-in</u> → Card / Card → Built-in / Cancel
Favorites	<u>Show</u> / Save / Delete / Cancel

● Set Up tab menu

Beep	<u>On</u> / Off
Startup	On / <u>Off</u>
Date Style	<u>YY/MM/DD</u> / DD/MM/YY / MM/DD/YY
Adjust	Time setting
Language	日本語 / <u>English</u> / Français / Deutsch / Español / Italiano
Format	Format / <u>Cancel</u>

Indicator Lamp Reference

Camera Indicator Lamps

The camera has two indicator lamps: an operation/flash charge lamp and a self-timer lamp. These lamps light and flash to indicate the current operational status of the camera.

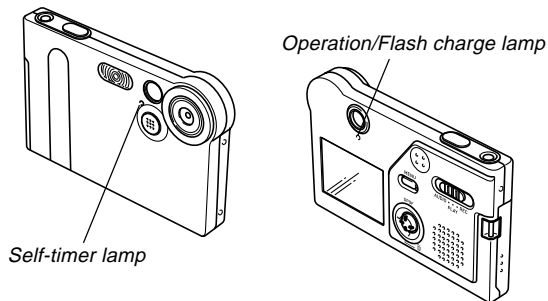

* There are two lamp flash patterns.
Pattern 1 flashes once per second, while Pattern 2 flashes twice per second. The table below explains what each flash pattern indicates.

■ REC Mode

Operation/Flash Charge Lamp		Self-timer Lamp		Meaning
Color	Status	Color	Status	
Green	Lit			Power on
Amber	Pattern 1			Flash charging
Green	Lit			Monitor screen off
Green	Pattern 2			Storing image
Green	Pattern 1	Red	Pattern 1	Self-timer countdown (10 to 3)
Green	Pattern 2	Red	Pattern 2	Self-timer countdown (3 to 1)
Red	Lit			Memory error
Red	Lit			Memory full
Red	Pattern 1			Low battery alert
Red	Pattern 1			Monitor screen disabled
Green	Pattern 2			Powering down

▶▶▶ IMPORTANT! ◀◀◀

- Never remove the memory card from the camera while the operation/flash charge lamp is flashing. Doing so will cause recorded images to be lost.

■ PLAY Mode

Operation/Flash Charge Lamp		Self-timer Lamp		Meaning
Color	Status	Color	Status	
Green	Lit			Power on
Green	Pattern 2			Deleting image
Red	Lit			Memory error
Red	Pattern 1			Low battery alert
Green	Pattern 2			Formatting
Green	Pattern 2			Powering down

■ AUDIO Mode (EX-M2 only)

Operation/Flash Charge Lamp		Self-timer Lamp		Meaning
Color	Status	Color	Status	
Green	Lit			Power on, LCD remote controller not connected

USB Cradle Indicator Lamps

The USB cradle has two indicator lamps: a CHARGE lamp and a USB lamp. These lamps light and flash to indicate the current operational status of the cradle and camera.

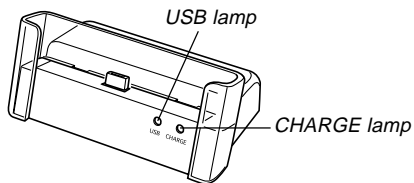

CHARGE lamp		USB lamp		Meaning
Color	Status	Color	Status	
Red	Lit			Charging
Green	Lit			Charging complete
Amber	Lit			Charge standby
Red	Flashing			Charge error
		Green	Lit	USB connection
		Green	Flashing	Accessing computer

Troubleshooting Guide

	Symptom	Possible Cause	Action
Power Supply	Power does not turn on.	The battery is dead.	Charge the battery (page 24). If the battery goes dead soon after being charged, it means the battery has reached the end of its life and needs to be replaced. Purchase a separately available NP-20 rechargeable lithium ion battery.
	Camera suddenly powers down.	1) Auto Power Off activated (page 29). 2) The battery is dead.	1) Turn power back on. 2) Charge the battery (page 24).
Image Recording	Image is not recorded when the shutter release button is pressed.	1) Mode selector is set to "PLAY" or "AUDIO". 2) Flash unit is being charged. 3) Memory is full.	1) Align the mode selector with "REC". 2) Wait until the flash unit finishes charging. 3) Transfer files you want to keep to your computer and then delete files from camera memory, or use a different memory card.
	Camera powers down during self-timer countdown.	The battery is dead.	Charge the battery (page 24).
	Recorded images are not saved in memory.	1) Camera powers down before the save operation is complete. 2) Removing the memory card before the save operation is complete.	1) When the battery indicator shows  , charge the battery as soon as possible (page 24). 2) Do not remove the memory card before the save operation is complete.

APPENDIX

	Symptom	Possible Cause	Action
Playback	Color of the playback image is different from the image on the monitor screen during recording.	Sunlight or light from another source is shining directly into the lens during recording.	Position the camera so sunlight does not shine directly into the lens.
	Images are not displayed.	A memory card with non-DCF images recorded with another camera is loaded in the camera.	This camera cannot display non-DCF images recorded onto a memory card using another digital camera.
Audio Playback	Cannot playback audio, cannot hear audio, or cannot control the audio playback using the remote controller.	<ol style="list-style-type: none"> 1) Mode selector is set to "REC" or "PLAY". 2) There is no MP3 file data in memory. This is indicated by the message "NoData" on the remote controller LCD. 3) Stereo headphones are not connected correctly. 4) Volume setting is too low. 5) The battery is dead. 6) The remote controller buttons are locked. 7) There are no playable files. 8) Improper PLAYLIST.TXT file contents 	<ol style="list-style-type: none"> 1) Align the mode selector with "AUDIO". 2) Transfer MP3 files to the camera's AUDIO folder. 3) Correctly connect the headphones to the headphones jack. 4) Adjust the volume to a higher level. 5) Charge the battery (page 24). 6) Slide the remote controller lock switch in the opposite direction of the arrow marking to unlock the controls. 7) Check the files you are trying to play (page 96). 8) Check to make sure the PLAYLIST.TXT file lists the MP3 files you want to play.
	Playback time is short.	The battery is dead.	Charge the battery (page 24).

* Note that audio player capabilities are available with the EX-M2 only.

APPENDIX

	Symptom	Possible Cause	Action
Other	All buttons and switches are disabled.	Circuit problem caused by electrostatic charge, impact, etc. while the camera was connected to another device.	Remove the battery from the camera, reinsert it, and then try again.
	Monitor screen is off.	<ol style="list-style-type: none"> 1) "LCD-OFF" is selected for the "Indicators" setting on the REC tab. 2) USB communication is in progress. 	<ol style="list-style-type: none"> 1) On the REC tab menu, change the "Indicators" setting to "LCD-ON" (page 51). 2) After confirming that the computer is not accessing camera memory, disconnect the USB cable.
	Cannot transfer files over a USB connection.	<ol style="list-style-type: none"> 1) Camera is not set securely on the USB cradle. 2) USB cable is not connected securely. 3) USB driver is not installed. 4) Camera is turned off. 	<ol style="list-style-type: none"> 1) Check the connection between the camera and USB cradle. 2) Check all connections. 3) Install the USB driver on your computer (page 81). 4) Turn on the camera.

Display Messages

Memory Full Memory is full. If you want to record more files, delete files you no longer need (page 62).

Record Error Image compression could not be performed during image data storage for some reason. Record the image again.

Folder cannot be created. This message appears when you try to record an image while there are 9,999 files stored in the 999th folder. If you want to record more files, delete files you no longer need (page 62).

The card is locked. The LOCK switch of the SD memory card is locked. You cannot store images to or delete images from a memory card that is locked.

There are no files. There are no files in built-in memory or on the memory card.

This file cannot be played. The image file or audio file is corrupted, or is a type that cannot be displayed by this camera.

No Favorites file! There is no FAVORITE file.

This function cannot be used. You attempted to copy files from built-in memory to a memory card while there is no memory card loaded in the camera (page 79).

Battery is low. The battery is dead.

File could not be saved because battery is low. The battery is dead, so the recorded image or audio recording file could not be saved.

The card is not formatted. The memory card is not formatted. Format the memory card (page 78).

Card ERROR Some problem occurred with the memory card. Turn off the camera, and remove and then re-insert the memory card. If the same message appears, format the memory card (page 78).

»» IMPORTANT! ««

Formatting the memory card deletes all files on the memory card. Before formatting, try transferring recoverable files to a computer or some other storage device.

The function is not supported for this file. The function you are trying to perform is not supported for the file on which you are trying to perform it.

SYSTEM ERROR Your camera system is corrupted. Contact your retailer or a CASIO authorized service center.

Specifications

Main Specifications

Product Digital Camera

Model EX-S2/EX-M2

■ Camera Functions

Image Files Format

Snapshots: JPEG (Exif Version 2.2); DCF (Design Rule for Camera File System)1.0 standard; DPOF compliant

Movies: AVI (Motion JPEG)

Audio: WAV (EX-M2 only)

Recording Media: 12MB built-in flash memory
SD Memory Card
MultiMedia Card

Image Size

Snapshots: 1600 x 1200pixels
1280 x 960pixels

640 x 480pixels

Movies: 320 x 240pixels

Approximate Memory Capacity and File sizes

• Snapshots

File Size (pixels)	Quality	Approximate Image File Size	Built-in flash memory 12MB	SD Memory Card* 64MB
1600 x 1200 (UXGA)	Fine	900KB	11 shots	60 shots
	Normal	630KB	16 shots	85 shots
	Economy	370KB	29 shots	154 shots
1280 x 960 (SXGA)	Fine	680KB	15 shots	82 shots
	Normal	460KB	24 shots	126 shots
	Economy	250KB	42 shots	220 shots
640 x 480 (VGA)	Fine	190KB	56 shots	294 shots
	Normal	140KB	74 shots	386 shots
	Economy	90KB	118 shots	618 shots

• Movies (320 x 240 pixels)

Data Size	150KB/second max.
Recording Time	One Movie: 30 seconds maximum Total Movie Time: 80 seconds maximum (built-in memory) 410 seconds maximum (SD 64MB memory card)*

* Based on Matsushita Electric Industrial Co., Ltd. products. Capacity depends on card manufacturer.

* To determine the number of images that can be stored on a memory card of a different capacity, multiply the capacities in the table by the appropriate value.

APPENDIX

Delete	Single-file, all files (with protection)
Effective Pixels:	2.0 million
Imaging Element:	1/1.8-inch square pixel color CCD (Total pixels: 2.11 million)
Lens/Focal Distance	F3.2/f = 7.5mm (Equivalent to 36mm on a 35mm film camera.)
Zoom	4X digital zoom
Focusing	Fixed focal point
Approximate Focus Range (from lens surface)	1m to ∞
Exposure Control	
Metering:	Multi-pattern by imaging element
Exposure:	Program AE
Exposure Compensation: ...	-2EV to +2EV (in 1/3EV steps)
Shutter	CCD shutter, mechanical shutter 1/4 to 1/7000 second
Aperture:	F3.2 fixed
White Balance	Automatic/fixed (4 modes) /Manual
Self-timer	10 seconds
Built-in Flash	
Flash Modes:	Auto, Off, On, Red-eye reduction
Approximate Flash Range: ...	1 meter to 2 meters

Recording Functions	Snapshot (with audio for EX-M2 only); self-timer; Best Shot; Movie (with audio for EX-M2 only); voice recording (EX-M2 only) * Audio is monaural
Audio Recording Time (EX-M2 only)	
Audio Snapshot:	Approximately 30 seconds maximum per image
Voice Recording:	Approximately 50 minutes with built-in memory
After Recording:	Approximately 30 seconds maximum per image
Monitor Screen	1.6-inch TFT color LCD 84,960 pixels (354 x 240)
Viewfinder	Monitor screen and optical viewfinder
Timekeeping Functions ...	
Built-in quartz digital clock	
Date and Time:	Recorded with image data
Auto Calendar:	To 2049
Input/Output Terminals ...	Cradle connector (EX-M2 connector is also used for connection of remote controller.)
Speaker	20mm round, monaural (EX-M2 only)

■ Audio Player Function (EX-M2 Only)

Data Compression/

Decompression MP3 (MPEG-1 Audio Layer-3)

Sampling Frequencies 32kHz, 44.1kHz, 48kHz

Bit Rates 32 to 320 kbps, VBR-compatible

Play Mode Normal, all track repeat, 1-track repeat

Practical Maximum

Headphone Output 9mW + 9mW (16 Ω)

A bit rate of 128kbps and a sampling frequency of 44.1kHz are recommended for MP3 files.

■ Power Supply

Power Requirements Rechargeable lithium ion battery (NP-20) x 1

Approximate Battery Life:

Continuous Recording	65 minutes (390 shots)
Continuous Playback (Continuous Snapshot Recording)	110 minutes
Continuous Voice Recording*	80 minutes
Continuous Audio Playback*	330 minutes

The values noted above are approximate values until power fails at normal temperature (25°C)(page 26). The above does not guarantee that you will be able to achieve this level of operation. Low temperatures shorten battery life. Voice recording times are based on continuous recording, while audio playback times are based on continuous output (through headphones).

* Voice recording and audio playback times apply to the EX-M2 only.

Power Consumption DC 3.7V Approximately 3.1W

APPENDIX

■ Other

Dimensions

EX-S2: 88(W) x 55(H) x 11.3(D) mm
(3.5"(W) x 2.2"(H) x 0.4"(D))
(excluding projections)

EX-M2: 88(W) x 55(H) x 12.4(D) mm
(3.5"(W) x 2.2"(H) x 0.5"(D))
(excluding projections)

Weight

EX-S2: Approximately 88 g (3.1 oz)
(excluding battery and accessories)

EX-M2: Approximately 90 g (3.2 oz)
(excluding battery and accessories)

Bundled Accessories Rechargeable lithium ion battery (NP-20); USB Cradle; Special AC Adaptor; AC power cord; Strap; Special USB cable; Dummy Card; Connector Cover; LCD Remote Controller (bundled with EX-M2 only); Stereo Headphones (bundled with EX-M2 only); CD-ROM; Basic Reference; Rechargeable Lithium Ion Battery User's Guide

■ USB Cradle

Input/Output Terminals Camera connector; USB port; AC adaptor terminal (DC IN 5.3V)

Power Consumption DC 5.3V Approximately 3.4W

Dimensions 95(W) x 55.5(H) x 39.5(D) mm
(3.7"(W) x 2.2"(H) x 1.6"(D))
(excluding projections)

Weight Approximately 56 g (2.0 oz)

■ LCD Remote Controller (Bundled with EX-M2 Only)

Input/Output Terminals Camera connector; headphones jack (ø3.5mm stereo mini jack)

Cord Length Approximately 0.8m (31.5")

Dimensions 74.5(W) x 16(H) x 11(D) mm
(2.9"(W) x 0.6"(H) x 0.4"(D))
(excluding projections, excluding cradle)

Weight Approximately 28 g (1.0 oz)

Power Supply

- Use only the special NP-20 rechargeable lithium ion battery to power this camera. Use of any other type of battery is not supported.
- This camera does not require a battery for the clock. The date and time settings of the camera are cleared whenever power supplied by both the battery and USB cradle is interrupted. Be sure to reconfigure these settings after power is interrupted (page 32).

LCD Panel

- The LCD panel is a product of the latest LCD manufacturing technology that provides a pixel yield of 99.99%. This means that less than 0.01% of the total pixels are defective (they do not turn on or always remain turned on).